

**BANJO TEE COUPLING WITH ALLOW SCREW AND ELASTOMER SEAL**  
Thread BSP Parallel - Thread Metric Parallel

Type: **1015...1** Only Body  
Type: **1016...1** Only Body

Type: **1015..** B3 Ring  
Type: **1016..** B3 Ring

Type: **1015..4** B4 Ring  
Type: **1016..4** B4 Ring

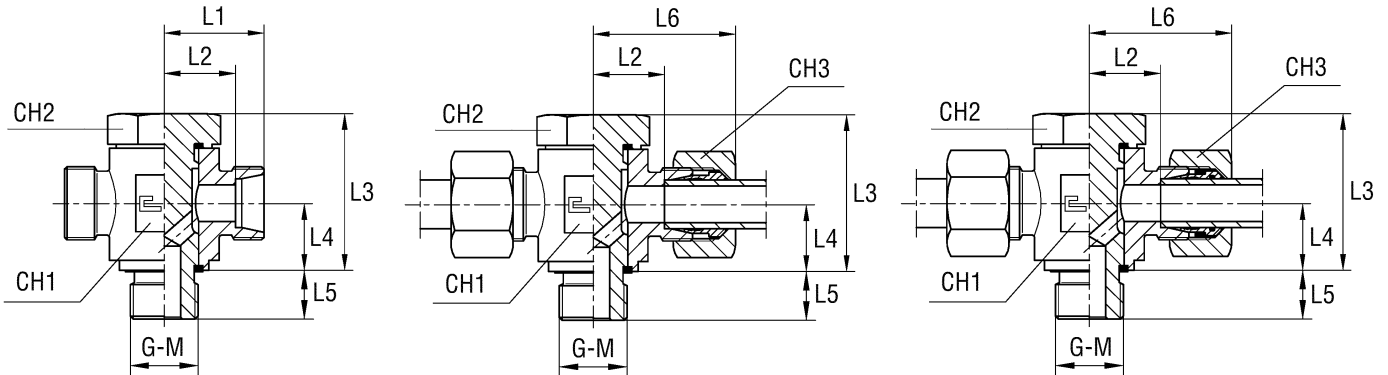

Serie	Bar	Ordering Body	Ordering Equipped B3	Ø Tube	G	L1	L2	L3	L4	L5	L6	CH1	CH2	CH3	Ordering Equipped B4
L	315	101504.1	101504	6	1/8	19	12	18,5	10,5	8	27	17	17	14	101504.4
		101505.1	101505	8	1/4	21,5	14,5	25	14	12	29,5	22	19	17	101505.4
		101506.1	101506	10	1/4	22,5	15,5	25	14	12	30,5	22	19	19	101506.4
		101507.1	101507	12	3/8	25	18	30	16,5	12	33	27	24	22	101507.4
		101508.1	101508	15	1/2	29	22	37,5	21,5	14	37	32	30	27	101508.4
	101509.1	101509	18	1/2	29	21,5	37,5	21,5	14	38	32	30	32	101509.4	
	160	101510.1	101510	22	3/4	34	26,5	44	24	16	43	41	36	36	101510.4
		101511.1	101511	28	1	38,5	31	55,5	30,5	18	47,5	50	46	41	101511.4
		101512.1	101512	35	1 1/4	45,5	35	65,5	35,5	20	56,5	60	55	50	101512.4
		101513.1	101513	42	1 1/2	50,5	39,5	75,5	40,5	22	62,5	70	60	60	101513.4
S	630	101514.1	101514	6	1/4	23,5	16,5	25	14	12	31,5	22	19	17	101514.4
		101515.1	101515	8	1/4	23,5	16,5	25	12	12	31,5	22	19	19	101515.4
		101516.1	101516	10	3/8	26	18,5	30	16,5	12	35	27	24	22	101516.4
		101517.1	101517	12	3/8	26	18,5	30	16,5	12	35	27	24	24	101517.4
		101518.1	101518	14	1/2	31	23	37,5	21,5	14	41	32	30	27	101518.4
	400	101519.1	101519	16	1/2	31	22,5	37,5	21,5	14	41	32	30	30	101519.4
		101520.1	101520	20	3/4	36	25,5	44	24	16	47	41	36	36	101520.4
		101521.1	101521	25	1	42,5	31,5	55,5	30,5	18	54,5	50	46	46	101521.4
		101522.1	101522	30	1 1/4	49,5	36	65,5	35,5	20	62,5	60	55	50	101522.4
		101523.1	101523	38	1 1/2	56,5	40,5	75,5	40,5	22	71,5	70	60	60	101523.4

**Note:** If you wish to order a fitting in stainless steel, please change the first two digit from **10..** to **11..**  
Articles not included in ISO 8434-1 norm available on scheduled orders only

Serie	Bar	Ordering Body	Ordering Equipped B3	Ø Tube	M	L1	L2	L3	L4	L5	L6	CH1	CH2	CH3	Ordering Equipped B4
L	315	101604.1	101604	6	10x1	19	12	18,5	10,5	8	26	17	17	14	101604.4
		101605.1	101605	8	12x1,5	21,5	14,5	25	14	12	29,5	22	19	17	101605.4
		101606.1	101606	10	14x1,5	22,5	15,5	25	14	12	30,5	22	19	19	101606.4
		101607.1	101607	12	16x1,5	25	18	30	16,5	12	33	27	24	22	101607.4
		101608.1	101608	15	18x1,5	29	22	33,5	18,5	12	37	32	27	27	101608.4
	101609.1	101609	18	22x1,5	29	21,5	37,5	21,5	14	38	32	30	32	101609.4	
	160	101610.1	101610	22	26x1,5	34	26,5	44	24	16	43	41	36	36	101610.4
		101611.1	101611	28	33x2	38,5	31	55,5	30,5	18	47,5	50	46	41	101611.4
		101612.1	101612	35	42x2	45,5	35	65,5	35,5	20	56,5	60	55	50	101612.4
		101613.1	101613	42	48x2	50,5	39,5	75,5	40,5	22	62,5	70	60	60	101613.4
S	630	101614.1	101614	6	12x1,5	23,5	16,5	25	14	12	31,5	22	19	17	101614.4
		101615.1	101615	8	14x1,5	23,5	16,5	25	14	12	31,5	22	19	19	101615.4
		101616.1	101616	10	16x1,5	26	18,5	30	16,5	12	35	27	24	22	101616.4
		101617.1	101617	12	18x1,5	29	21,5	33,5	18,5	12	38	32	27	24	101617.4
		101618.1	101618	14	20x1,5	31	23	36	20	14	41	32	30	27	101618.4
	400	101619.1	101619	16	22x1,5	31	22,5	37,5	21,5	14	41	32	30	30	101619.4
		101620.1	101620	20	27x2	36	25,5	44	24	16	47	41	36	36	101620.4
		101621.1	101621	25	33x2	42,5	31,5	55,5	30,5	18	54,5	50	46	46	101621.4
		101622.1	101622	30	42x2	49,5	36	65,5	35,5	20	62,5	60	55	50	101622.4
		101623.1	101623	38	48x2	56,5	40,5	75,5	40,5	22	71,5	70	60	60	101623.4

**Note:** If you wish to order a fitting in stainless steel, please change the first two digit from **10..** to **11..**  
Articles not included in ISO 8434-1 norm available on scheduled orders only