

TECHNIKA NAPĘDOWA ŁAPY DO SILNIKÓW ELEKTRYCZNYCH I POMP

ANELLO DI ESTRAZIONE E CENTRAGGIO POMPA CENTERING AND EXTRACTION RING

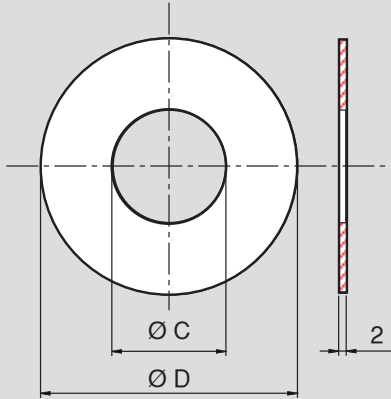

LANTERNA BELL HOUSING	ANELLO DI CENTRAGGIO CENTERING RING	DIMENSIONI DIMENSIONS		POMPA / PUMP
		Ø D	Ø C	
140 M - 160 M 200 M - 250 M	A1 254	67,5	25,4	1CA - 1UN
	A1 300	67,5	30	1MA
	A1 365	67,5	36,5	2UN
200 C - 250 C 300 M	A2 365	88	36,5	2UN
	A2 508	88	50,8	25T - 3MA - 3TS - 3UN
	A2 600	88	60	35M
	A2 603	88	60,3	35G - 35U
350 M	A3 508	110	50,8	25T - 3MA - 3TS - 3UN
	A3 600	110	60	35M
	A3 603	110	60,3	35G - 35U
	A3 635	110	63,5	4UN - 4TS - 4MA

PIEDINI - FOOT FLANGE

Fig. A

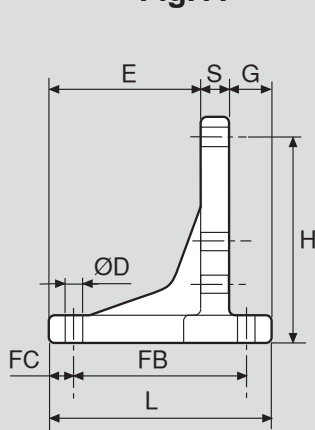
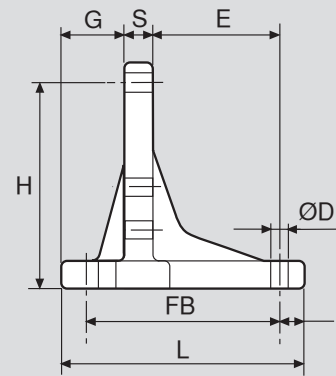
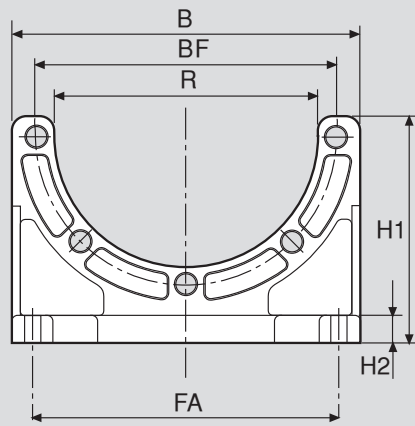

Fig. B



GRANDEZZA MOTORE MOTOR SIZE	PIEDINO FOOT FLANGE	DIMENSIONI / DIMENSIONS															LANTERNA BELL HOUSING
		FIG.	B	BF	R	FA	FB	FC	L	D	E	S	G	H	H1	H2	
71	BB 160	A	160	130	115	135	80	10	100	9	68	12	20	100	112	12	160
80 - 90	BB 200	A	200	165	140	176	103	13	128	11	88	15	25	123	138	15	200
100 - 112	BB 250	A	250	215	190	220	130	15	159	13	109	20	30	150	165	20	250
132	BB 300	A	300	265	240	265	160	18	190	13	135	20	35	180	198	20	300
160 - 180	BB 350	B	350	300	270	310	250	20	290	17	190	30	70	215	240	30	350

CENTRALA ELBLĄG

Ul. Rawska 19B
82-300 Elbląg

tel. /+48/ 55 625 51 00

fax /+48/ 55 625 51 01

Dział Handlowy

tel. /+48/ 55 625 51 51

elblag@hydropress.pl



www.hydropress.pl

ODDZIAŁ GDAŃSK

tel. /+48/ 55 625 51 21

fax /+48/ 55 625 51 22

ODDZIAŁ RUMIA

tel. /+48/ 58 679 34 15

fax /+48/ 55 625 51 25

ODDZIAŁ TYCHY

tel. /+48/ 32 787 52 88

fax /+48/ 55 625 51 38

ODDZIAŁ OLSZTYN

tel. /+48/ 89 532 01 05

fax /+48/ 89 715 21 42

ODDZIAŁ WARSZAWA

tel. /+48/ 22 468 86 97

fax /+48/ 55 625 51 32

BIURO WE WROCŁAWIU

tel. /+48/ 782 838 000

fax /+48/ 55 625 51 35

BIURO W KIELCACH

tel. /+48/ 885 995 501

fax /+48/ 55 625 51 01

BIURO W KRAKOWIE

tel. /+48/ 885 995 019

fax /+48/ 55 625 51 01

BIURO W OPOLU

tel. /+48/ 885 995 011

fax /+48/ 55 625 51 01

BIURO W BYDGOSZCZY

tel. /+48/ 790 222 771

fax /+48/ 55 625 51 01

BIURO W BIAŁYMSTOKU

tel. /+48/ 89 532 01 05

fax /+48/ 89 715 21 42

BIURO W ŁODZI

tel. /+48/ 609 221 421

fax /+48/ 89 715 21 42