

SILNIKI HYDRAULICZNE

SILNIKI ŁOPATKOWE

Vane Motors – 21,6 to 37,5 cm³/r (1.32 to 2.29 in³/r)



Characteristics

An economical, efficient and compact means of applying variable speed, rotary hydraulic power, these motors have variable horsepower (constant torque) characteristics. They can be stalled under load without damage when protected by a relief valve.

Hydraulic Balance

Two internal inlet chambers are diametrically opposed as are two outlet chambers. This construction eliminates bearing loads resulting from pressure, a major cause of wear in designs without this feature.

Efficiency

Optimum running clearances and hydraulic balance assure sustained high efficiency over the life of the motor.

Smooth Operation

Inertia of rotating parts is low ... parts are symmetrical, providing dynamic balance and freedom from vibration.

Operating Specifications

Model series	Torque Nm/6,9 bar (lb. in./100 psi)	Displ. cm ³ /r (in ³ /r)	Maximum torque Nm (lb. in.) @ max. pressure	Maximum speeds & pressures	Approx. weight lbs.
M2U	2,0 (18)	21,6 (1,32)	38,4 (340)	2800 r/min @ 138 bar (2000 psi)	7,7 (17)
	2,8 (25)	25,4 (1,55)	46,3 (410)	2500 r/min @ 138 bar (2000 psi)	
	4,0 (35)	37,5 (2,29)	67,8 (600)	2000 r/min @ 138 bar (2000 psi)	
M2-210	2,8 (25)	24,7 (1,51)	46,3 (410)	2200 r/min @ 138 bar (2000 psi)	9,5 (21)
	4,0 (35)	35,4 (2,16)	56,5 (500)	1800 r/min @ 121 bar (1750 psi)	

Model Codes

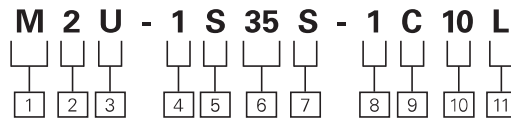

1 Vane motor

2 Series

3 Uni-directional rotation

4 Mounting
1 – 2-bolt flange

5 Inlet port
S – 1-5/16 – 12 st. thd.

6 Ring size – torque
(lb. in./100 psi)
18, 25 and 35

7 Outlet port
S – 1-5/16 – 12 st. thd.

8 Shaft type
1 – Straight keyed
3 – Threaded
11 – Splined

9 Outlet position
(Viewing cover end)
A – Outlet port opposite inlet
C – Port connections inline

10 Design
Subject to change. Installation dimensions remain the same for designs –10 through –19.

11 Rotation
L – Left hand (counterclockwise)
Omit for right hand (clockwise)

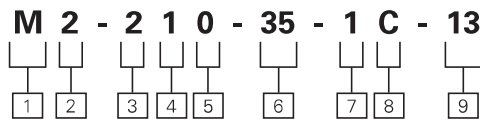

1 Vane motor

2 Series (bi-directional rotation)

3 Series frame size

4 Porting
1-3/4 NPT both ports

5 Mounting
0 – 2 bolt flange

6 Ring size – torque
lb. in./100 psi
25 and 35

7 Shaft type
1 – Straight keyed
3 – Threaded
6 – Straight keyed (stub)
11 – Splined

8 Cover position
(Viewing cover end)
A – Cover port opposite body port
B – Cover port 90 CCW from body port
C – Port connections in line
D – Cover port 90 CW from body port

9 Design
Subject to change. Installation dimensions remain the same for designs –10 through –19.

Installation Dimensions

M2U series

Dimensions in millimeters (inches)
Shaft options shown on page 101.

Model	Dimensions	
	A	B
M2U-1S18S-1C10	129,8 (5.11)	105,4 (4.15)
M2U-1S25S-1C10	136,1 (5.36)	111,8 (4.40)
M2U-1S35S-1C10	141,0 (5.55)	116,6 (4.59)

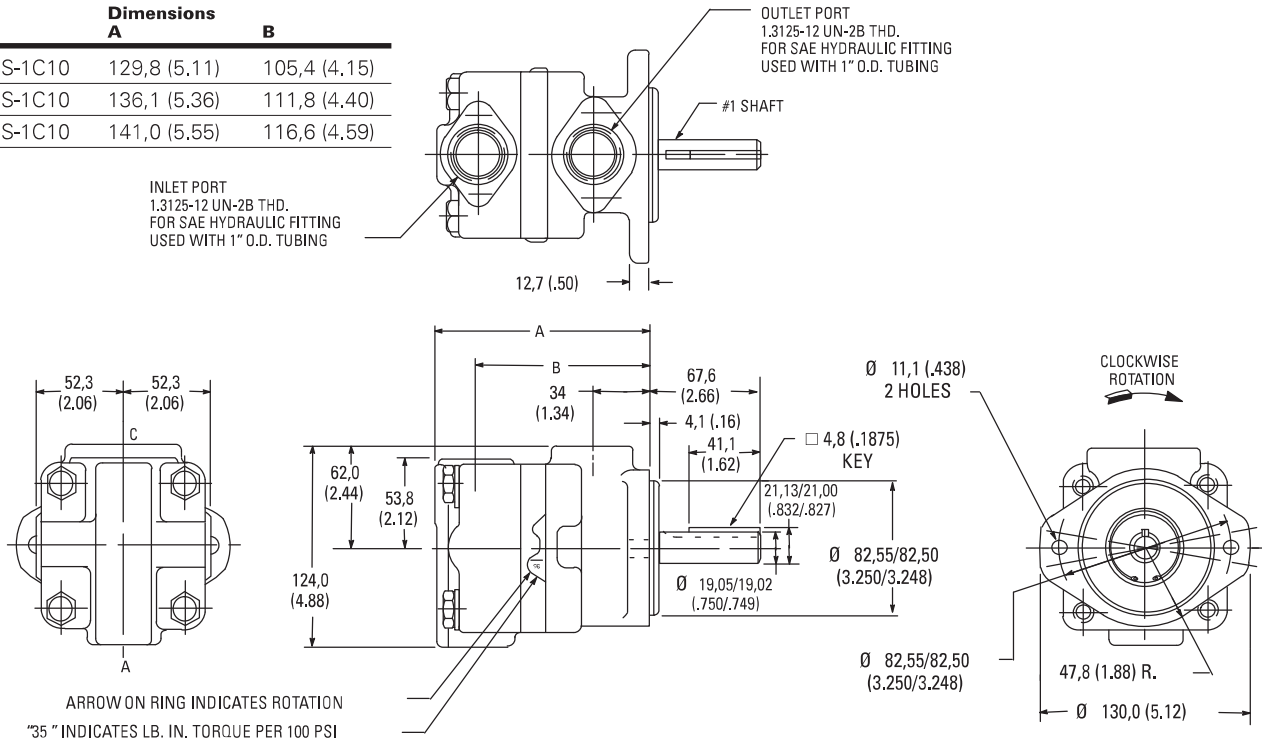

M2-200 series

Dimensions in millimeters (inches)
Shaft options shown on page 101.

Fluid supply to connection "L" provides clockwise shaft rotation, viewed from shaft end.

Fluid supply to connection "K" provides counterclockwise shaft rotation.

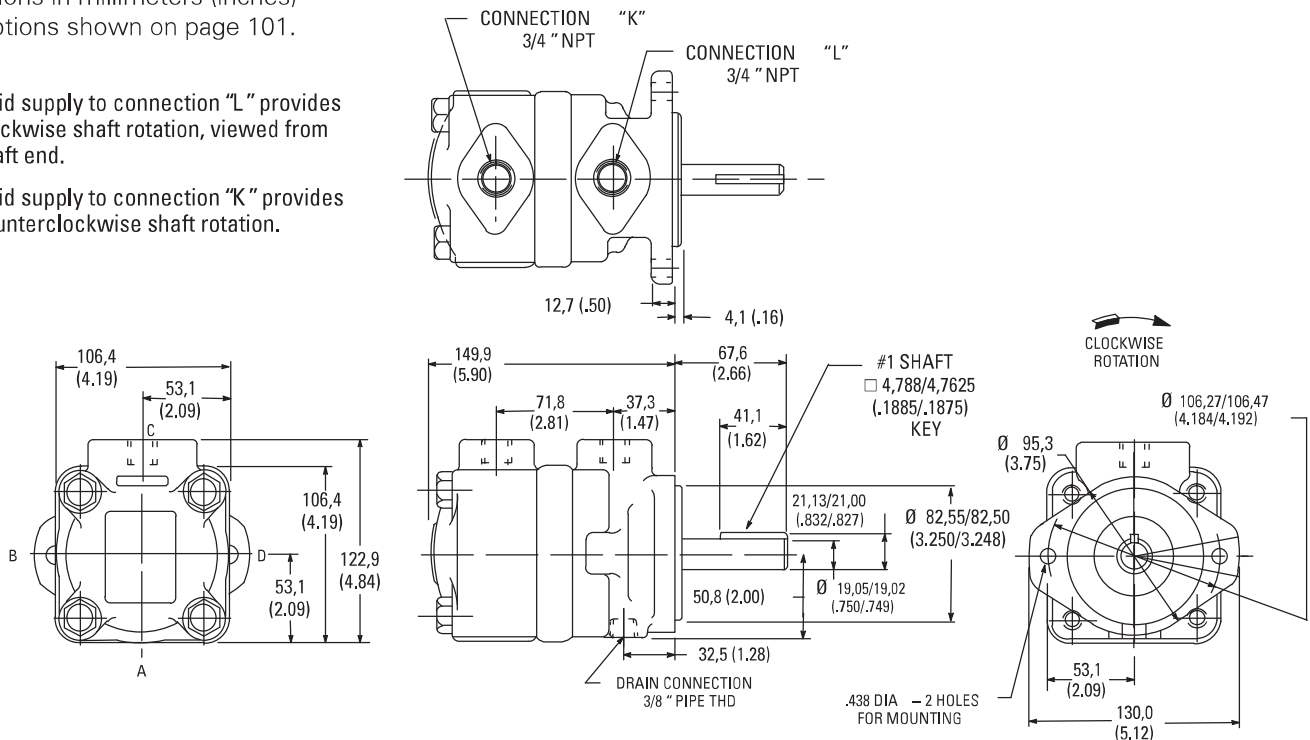

Optional Shafts

M2U & M2-200 series

Dimensions in millimeters (inches)

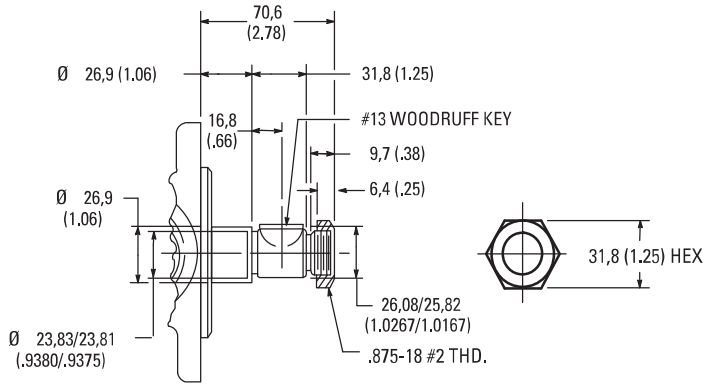

No. 3 threaded shaft

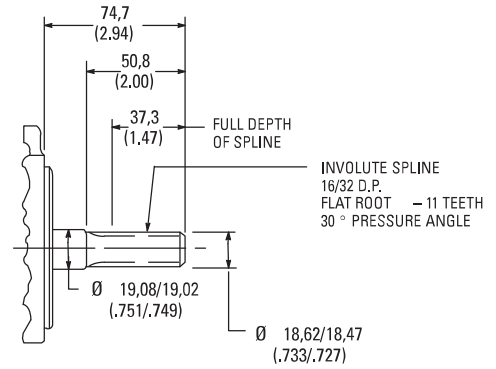

No. 11 splined shaft

NOTE:

Nut torque 169,5 Nm (125 lb. ft.)

M2-200 series

Dimensions in millimeters (inches)

NOTE: No. 1 keyed shaft is shown on page 100.

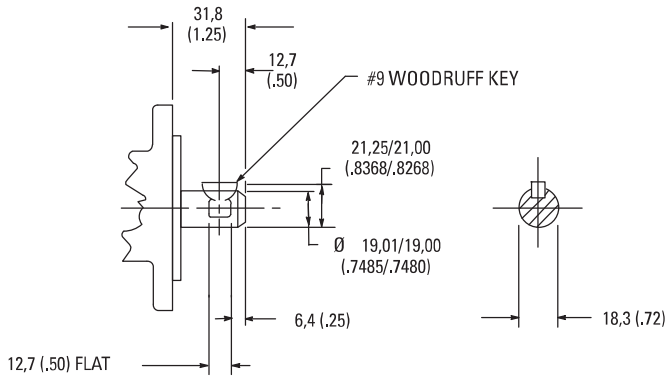

No. 6 straight stub shaft

Typical Performance

M2U Series

Performance Constants:

Oil temp. 49° C (120° F), viscosity
32 cSt (150 SUS) @ 38° C (100° F)

18 LB. IN. RING

25 LB. IN. RING

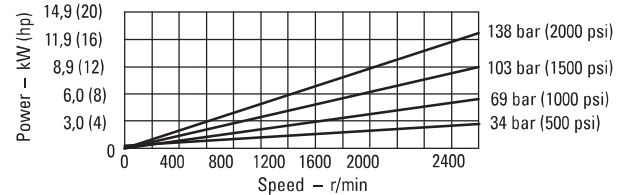
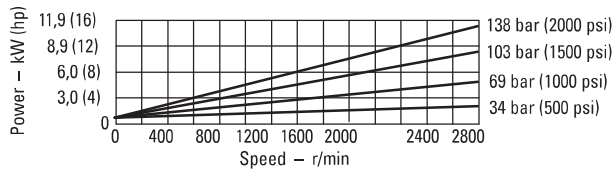
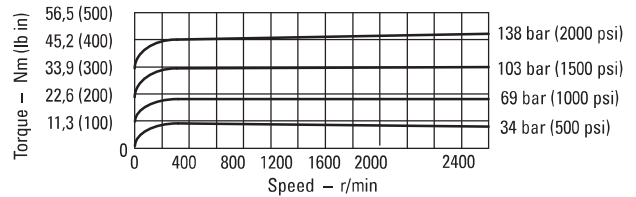
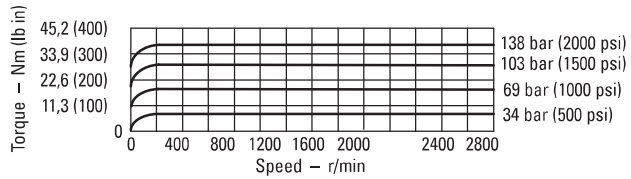
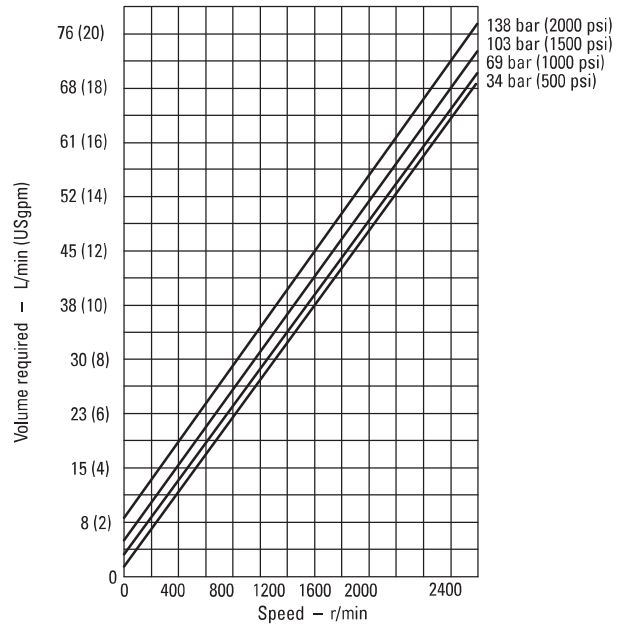
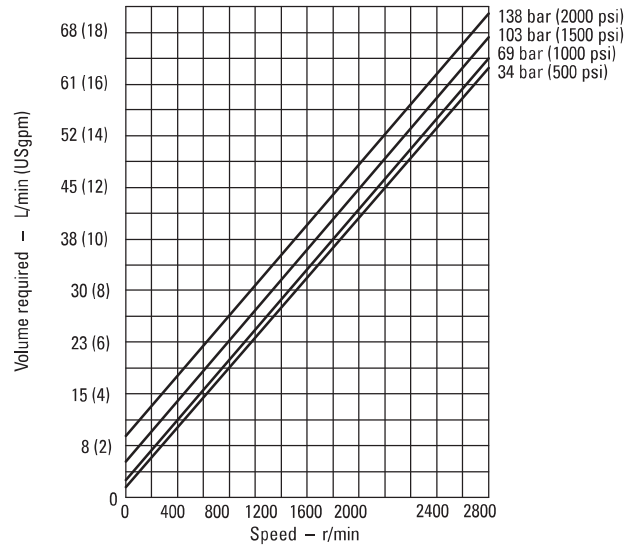

Typical Performance

M2U Series

Performance Constants:

Oil temp. 49° C (120° F), viscosity
32 cSt (150 SUS) @ 38° C (100° F)

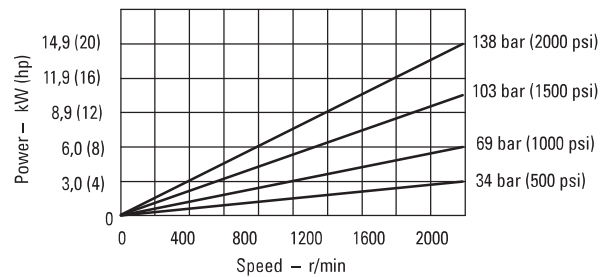
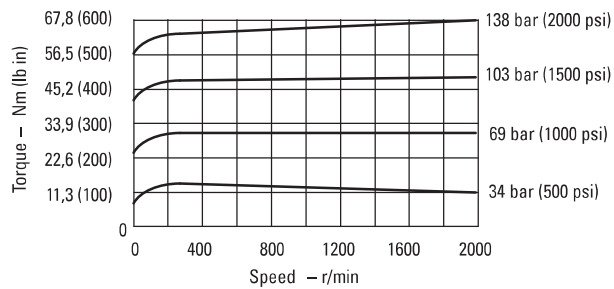
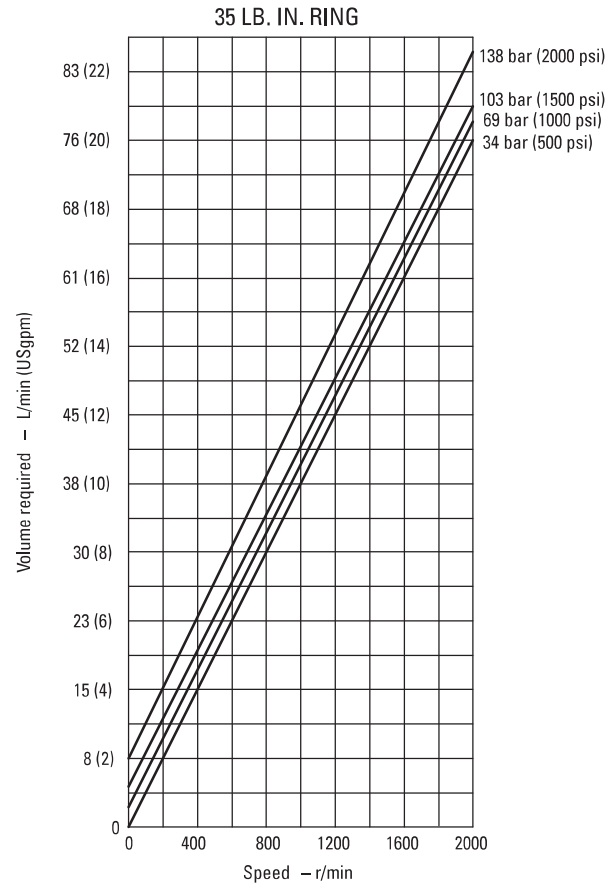

M2-200 Series

Performance Constants:

Oil temp. 49° C (120° F), viscosity
32 cSt (150 SUS) @ 38° C (100° F)

25 LB. IN. RING

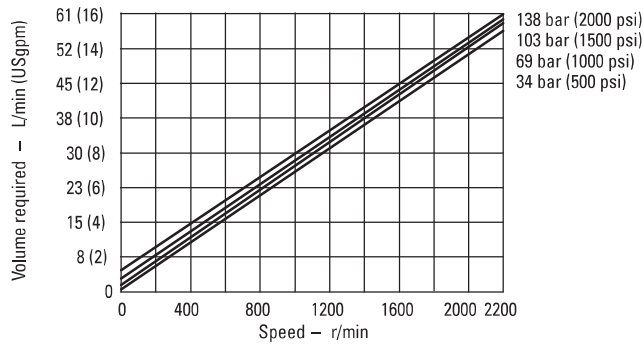

35 LB. IN. RING

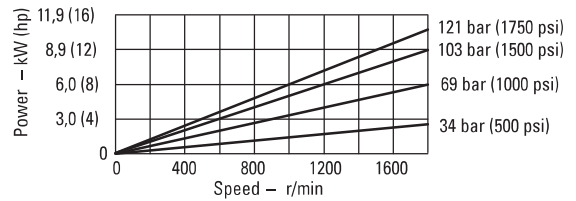
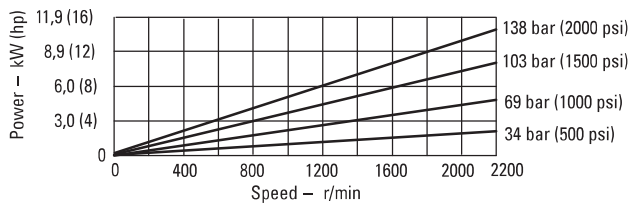
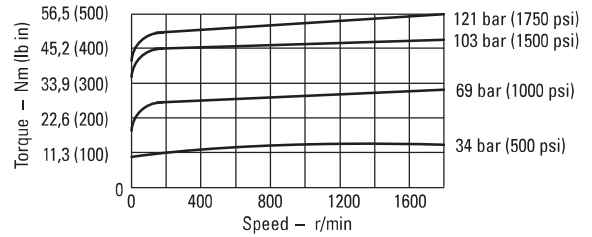
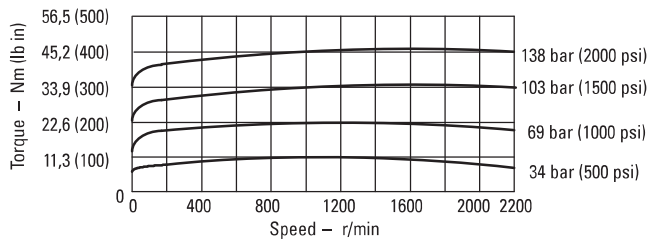
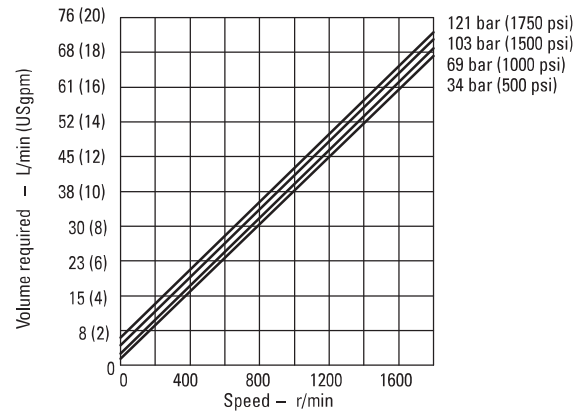

High Speed - High Pressure Motors from 43,9 to 317,1 cm³/r (2.68 to 19.35 in³/r)

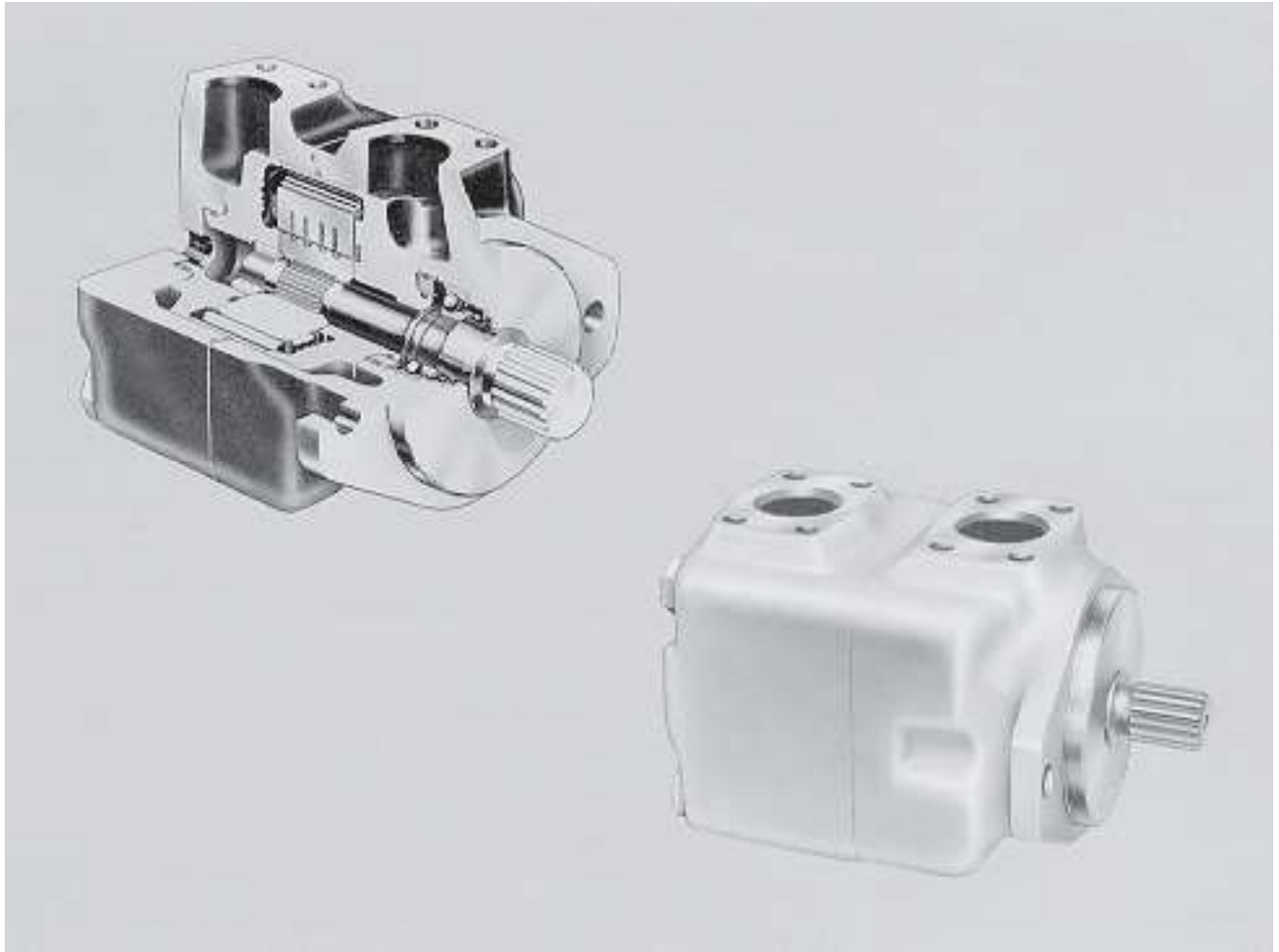

Reliable

Vickers has field-proved these high performance motors over many years. They have been overwhelmingly successful on elevator scraper drives, hydrostatic drives and many other auxiliary applications.

Efficient

Vickers' exclusive dual-alternate pressure plate design provides overall efficiency of about 86%.

Reversibility

Through the dual plate design, the motors may be reversed simply by reversing the direction of oil flow. See note below table on page 106 regarding pressure/rotation of model series 50M.

Series Operation

Inlet and outlet ports can be pressurized simultaneously without affecting service life or operating smoothness. These motors are suited to series applications. See note below table on page 106 regarding pressure/rotation of model series 50M.

Replaceable Cartridge

Replaceable cartridges permit motor overhauls in just 10 minutes - in the field! A cartridge can be replaced without removing the unit from the vehicle, and usually without disconnecting hydraulic lines.

High Speed and Pressure

These motors offer speeds to 3000 rpm at maximum pressure. Speeds up to 4000 rpm are obtainable, as in transmission applications where high travel speeds under light loads are required.

Operating Specifications

Model Series	Torque Nm/6,9 bar (lb. in./100 psi)	Displacement cm ³ /r (in ³ /r)	Flow Input @ 1200 r/min L/min (USgpm)	Max. Torque Nm (lb. in.) @ Max. Pressure	Maximum Speeds & Pressure	Approx. Weight kg (lb)
25M	4,7 (42) 6,2 (55) 7,3 (65)	43,9 (2.68) 57,7 (3.52) 68,7 (4.19)	52,7 (13.9) 69,4 (18.3) 82,6 (21.8)	115,8 (1025) 151,4 (1340) 180,8 (1600)	4000 r/min @ 34 bar (500 psi)	18 (40)
35M	9,0 (80) 10,7 (95) 13,0 (115)	83,6 (5.10) 100,3 (6.12) 121,9 (7.44)	100,4 (26.5) 120,5 (31.8) 146,3 (38.6)	221,5 (1960) 264,4 (2340) 320,9 (2840)		
45M	14,7 (130) 17,5 (155) 20,9 (185)	138,0 (8.42) 163,2 (9.96) 193,2 (11.79)	165,6 (43.7) 195,9 (51.7) 232,3 (61.3)	361,6 (3200) 429,4 (3800) 502,9 (4450)	3000 r/min @ 172 bar (2500 psi)	39 (85)
50M	24,9 (220) 28,8 (255) 33,9 (300)	231,3 (14.11) 268,2 (16.36) 317,2 (19.35)	277,8 (73.3) 322,2 (85.0) 380,7 (100.5)	615,9 (5450) 717,6 (6350) 844,1 (7470)	3200 r/min @ 34 bar (500 psi) 2400 r/min @ 172 bar (2500 psi)•	73 (160)

- 114 suffix: 2500 psi, counterclockwise
2250 psi, clockwise
- 124 suffix: 2500 psi, bi-directional

NOTE: Review “Applying Vane Units” page 7, prior to selection of motors.

Model Codes

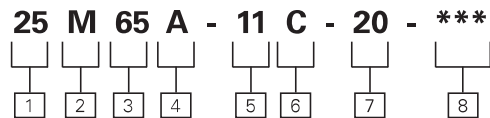

1 Series

25M }
35M } Standard
45M } bearing
50M }

26M }
36M } Heavy duty
46M } bearing
51M }

2 Vane motor

3 Ring size - Nominal torque rating

(lb. in./100 psi)

25M – 42, 55 & 65

35M – 80, 95 & 115

45M – 130, 155 & 185

50M – 220, 255 & 300

4 Mounting flange & port connections

A – SAE type 2-bolt mounting flange and SAE 4-bolt flange connections

5 Shaft

1 – Straight keyed

11 – Splined

6 Cover position

(Viewing cover end)

A – Cover port opposite body port

B – Cover port 90 CCW from body port

C – Port connections in line

D – Cover port 90 CW from body port

7 Design

Subject to change. Installation dimensions remain the same for designs –20 through –29.

8 Special features suffix

114 }
124 } 50M only

Installation Dimensions

25M Motors

Dimensions in millimeters (inches)
Shaft options shown on page 109

Port connection pads are for use with SAE 4-bolt flanges. See page 121 for selection.

Fluid supply to connection "L" turns shaft clockwise as viewed from shaft end. Fluid supply to connection "K" turns shaft counterclockwise.

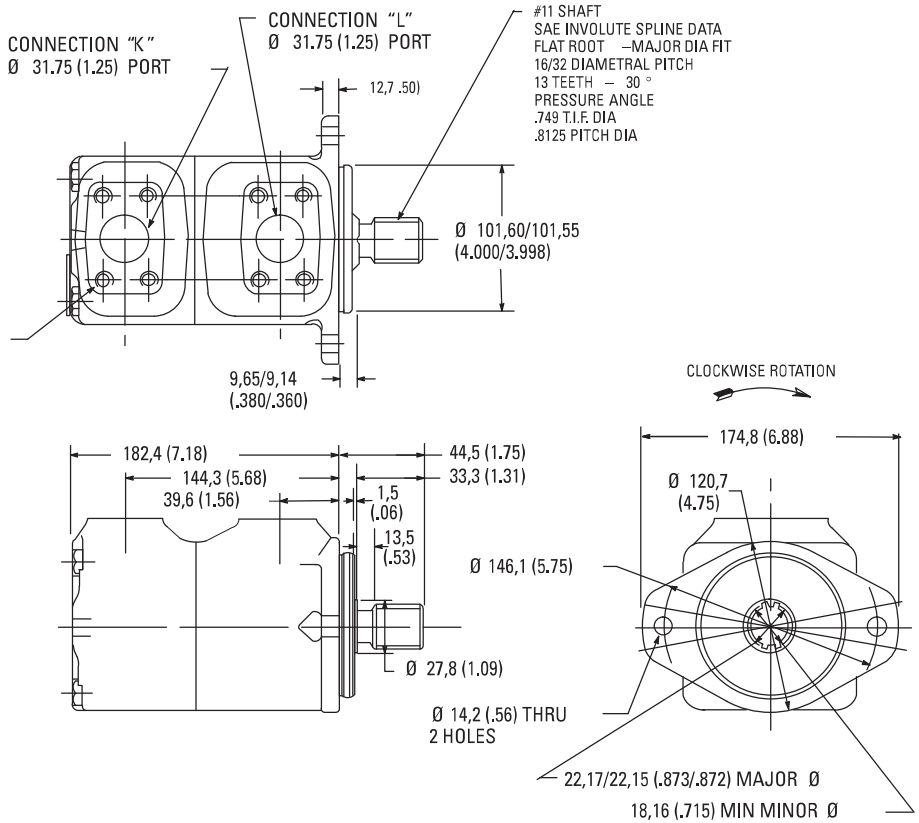
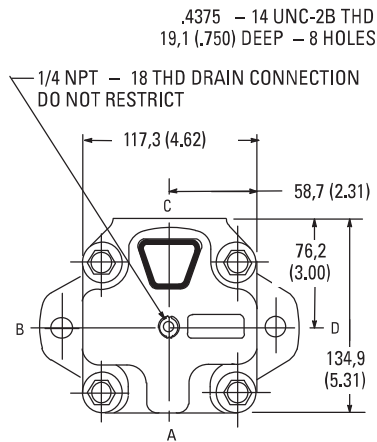

35M Motors

Dimensions in millimeters (inches)
Shaft options shown on page 109.

Port connection pads are for use with SAE 4-bolt flanges. See page 121 for selection.

Fluid supply to connection "L" turns shaft clockwise as viewed from shaft end. Fluid supply to connection "K" turns shaft counterclockwise.

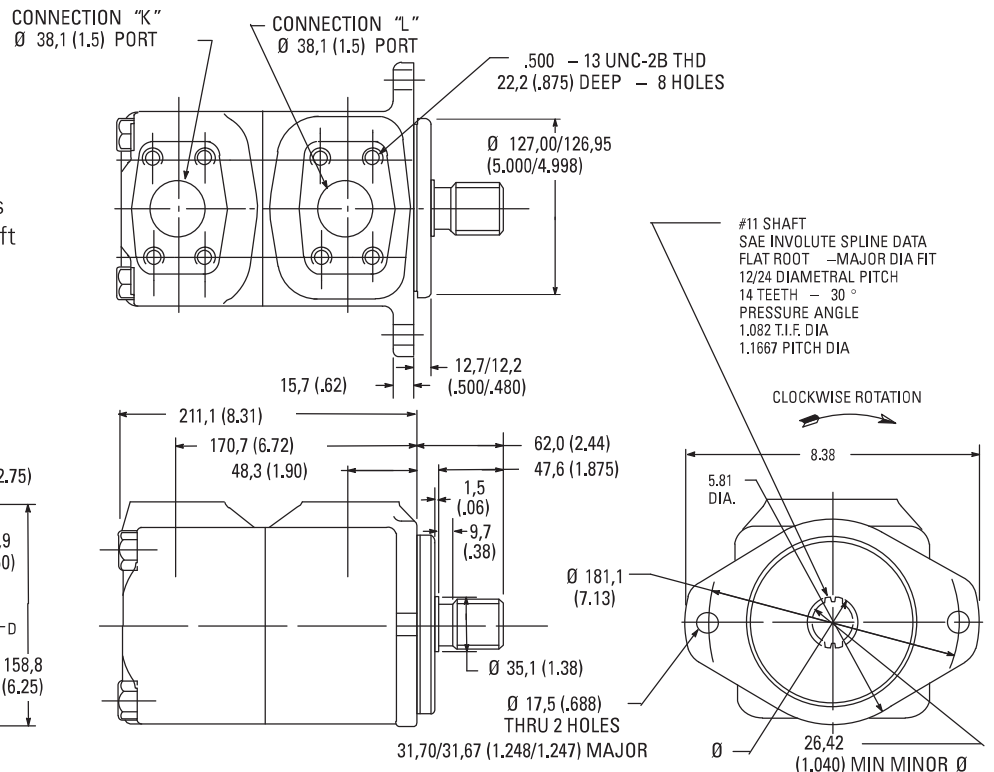
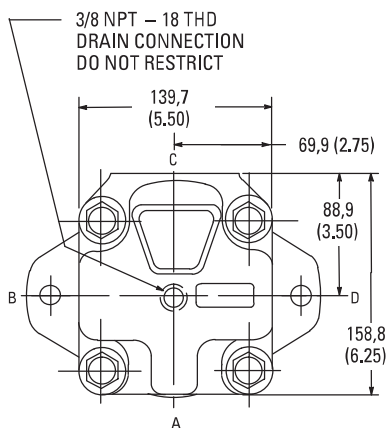

45M Motors

Dimensions in millimeters (inches)
Shaft options shown on page 109

Port connection pads are for use with SAE 4-bolt flanges. See page 121 for selection.

Fluid supply to connection "L" turns shaft clockwise as viewed from shaft end.
Fluid supply to connection "K" turns shaft counterclockwise..

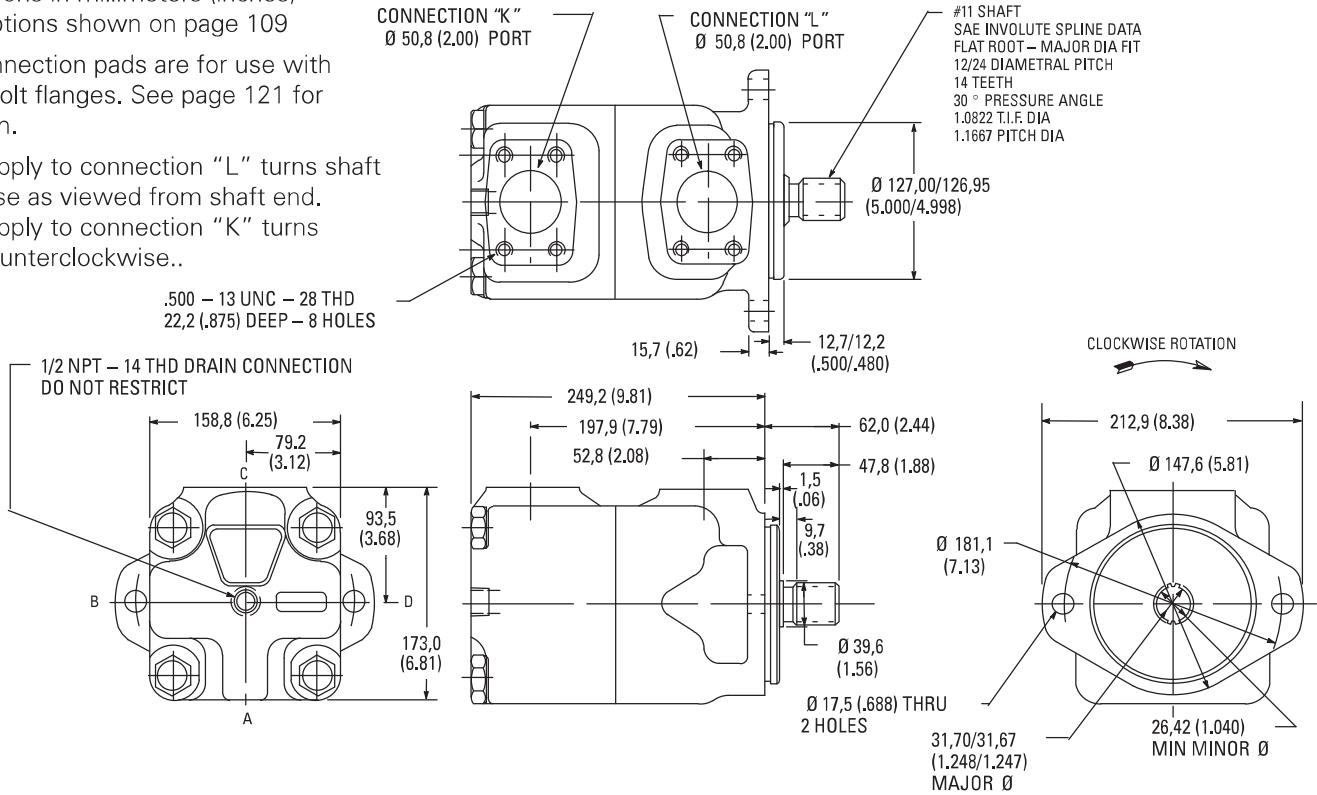

CONNECTION "K" Ø 63,5 (2,50) PORT
FLUID SUPPLY TO CONNECTION
"K" TURNS SHAFT COUNTERCLOCKWISE

CONNECTION "L" Ø 63,5 (2,50) PORT
FLUID SUPPLY TO CONNECTION
"L" TURNS SHAFT CLOCKWISE

50M Motors

Dimensions in millimeters (inches)
Shaft options shown on page 109.

Port connection pads are for use with SAE 4-bolt flanges. See page 121 for selection.

Fluid supply to connection "L" turns shaft clockwise as viewed from shaft end. Fluid supply to connection "K" turns shaft counterclockwise.

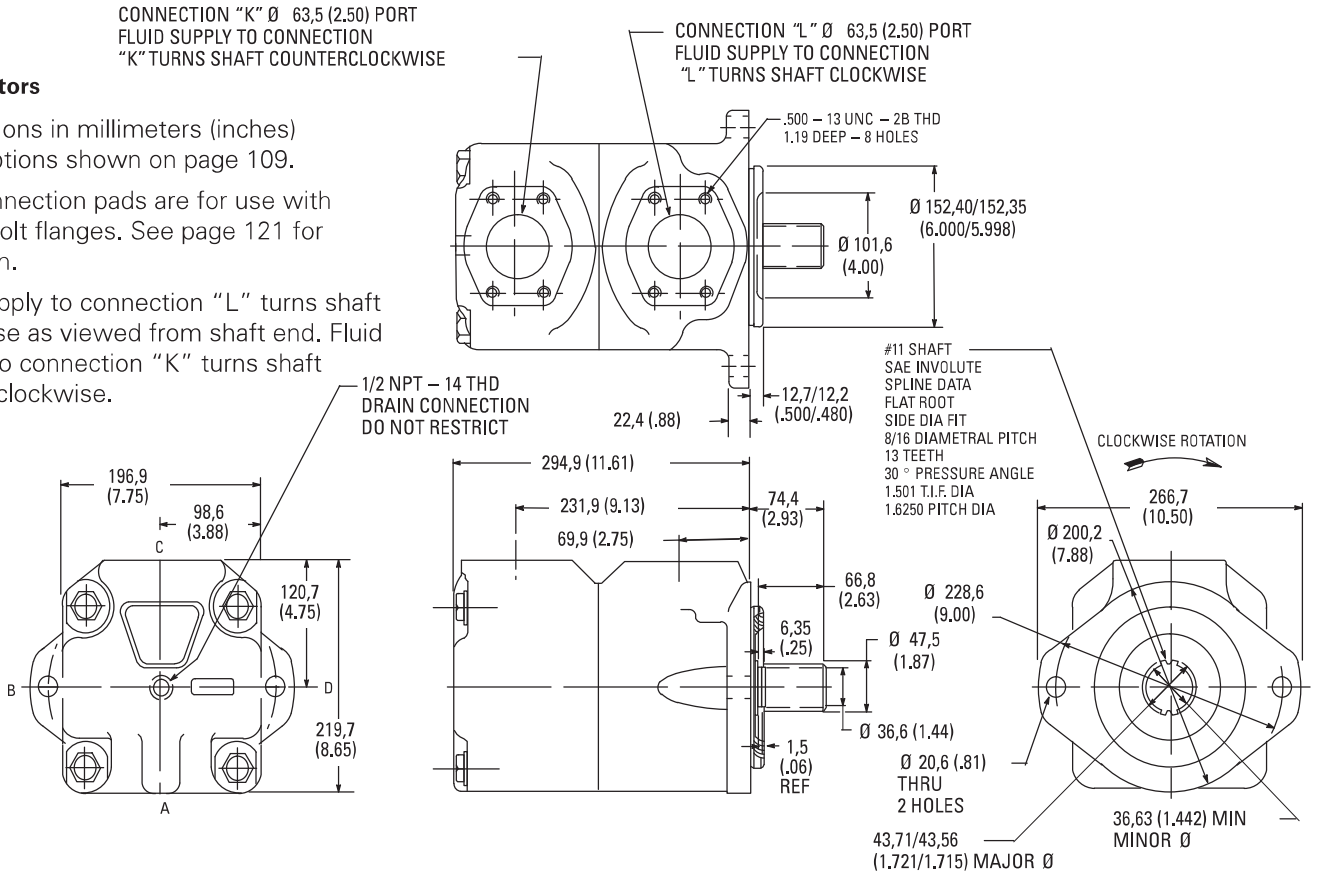

Optional Shafts

25M series

No. 1 straight keyed shaft

Dimensions in millimeters (inches)

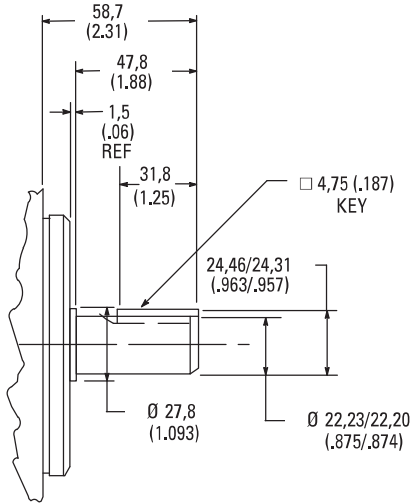

35M & 45M series

No. 1 straight keyed shaft

Dimensions in millimeters (inches)

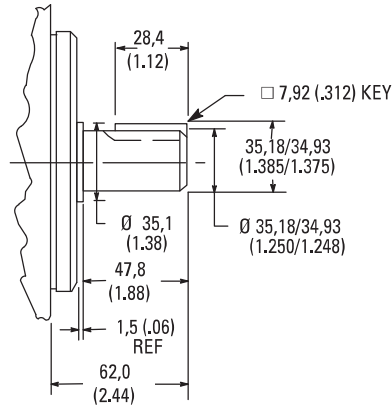

50M series

No. 1 straight keyed shaft

Dimensions in millimeters (inches)

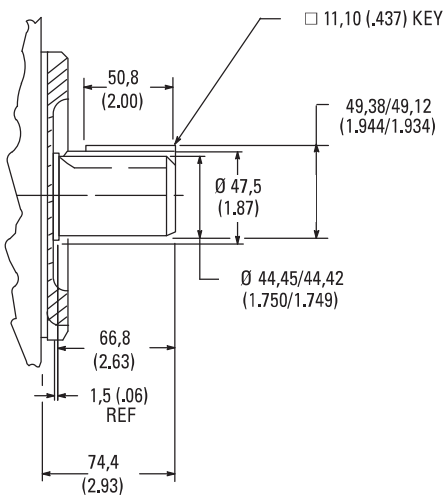

Typical Performance

25M Motors

Performance Constants:

Oil SAE 10W, viscosity 32 cSt (150 SUS) @ 38° C (100° F)

42 LB. IN. MODEL

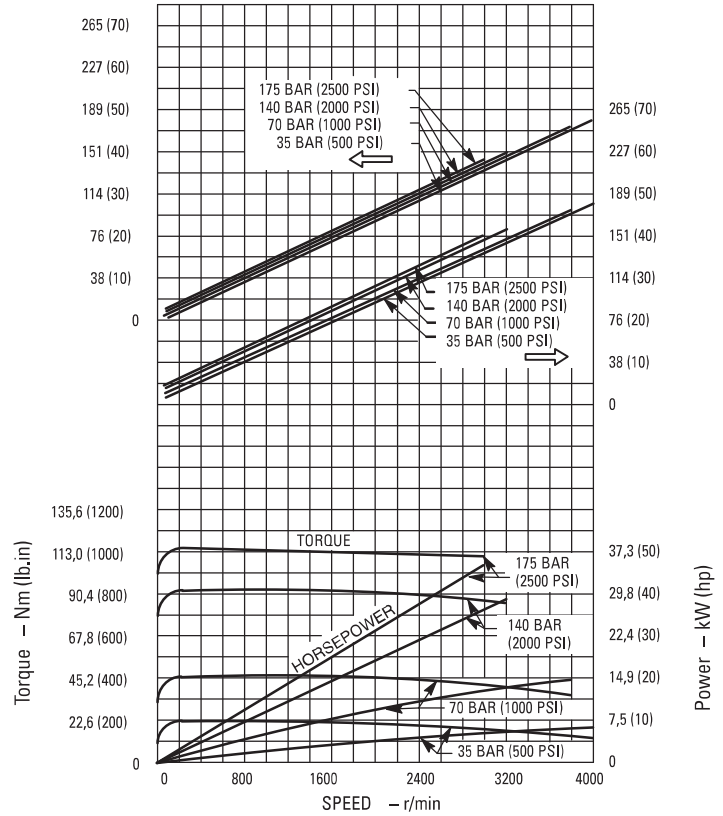

55 LB. IN. MODEL

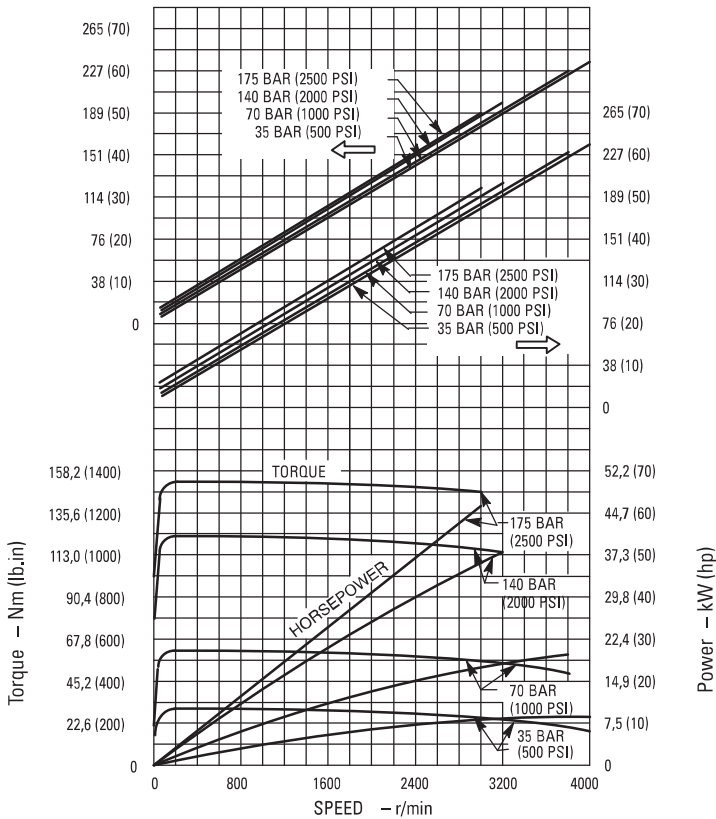

Typical Performance

25M Motors

Performance Constants:

Oil SAE 10W, viscosity 32 cSt (150 SUS) @ 38° C (100° F)

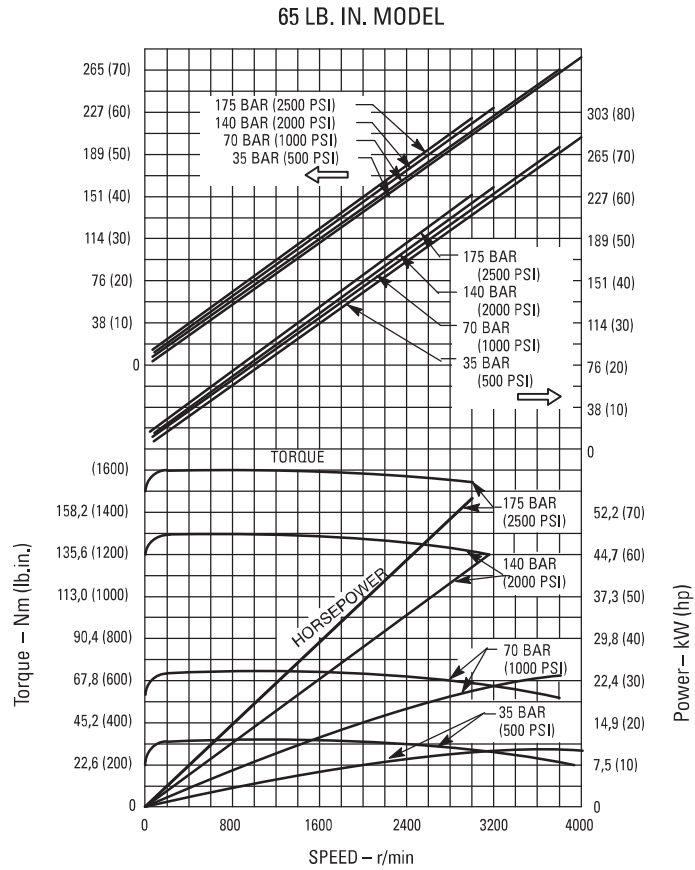

35M Motors

Performance Constants:

Oil SAE 10W, viscosity 32 cSt (150 SUS) @ 38° C (100° F)

80 LB. IN. MODEL

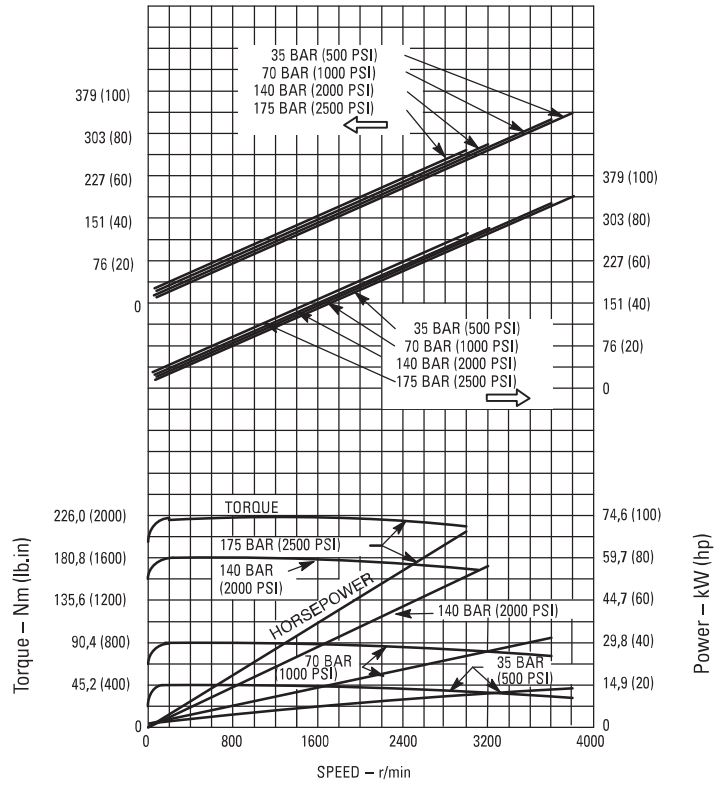

95 LB. IN. MODEL

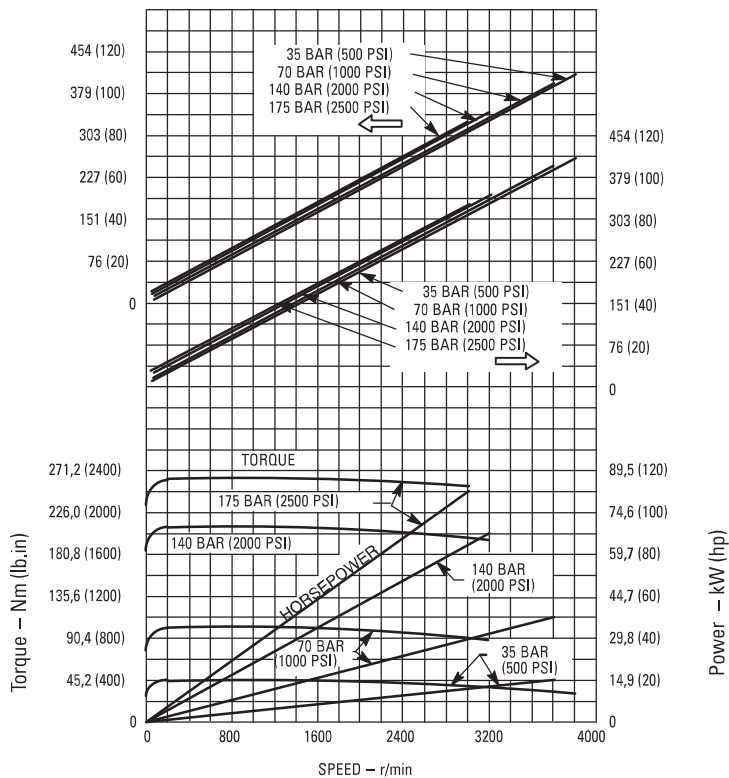

Typical Performance

35M Motors

Performance Constants:

Oil SAE 10W, viscosity 32 cSt (150 SUS) @ 38° C (100° F)

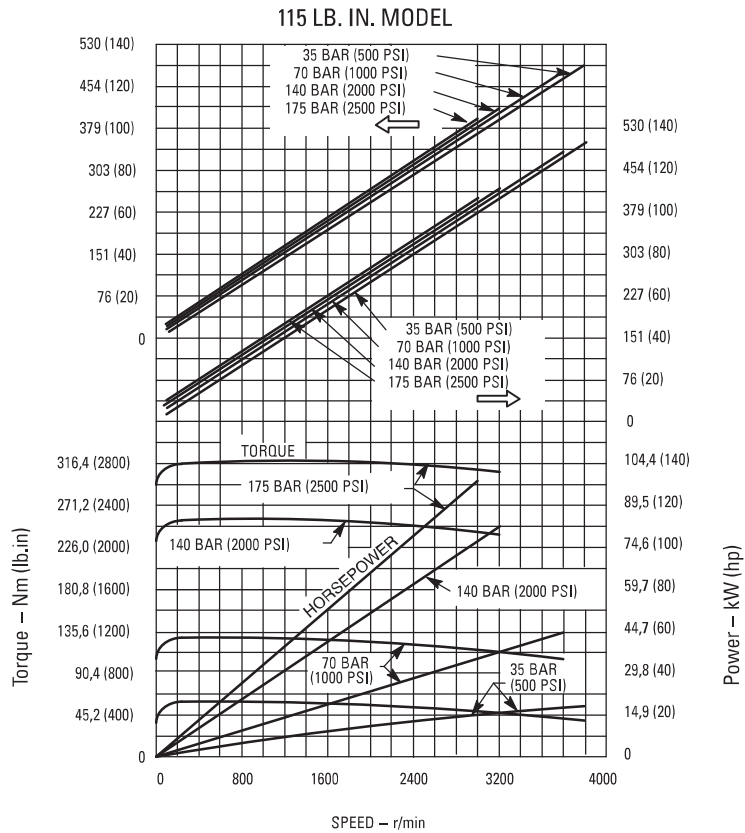

45M Motors

Performance Constants:

Oil SAE 10W, viscosity 32 cSt (150 SUS) @ 38° C (100° F)

130 LB. IN. MODEL

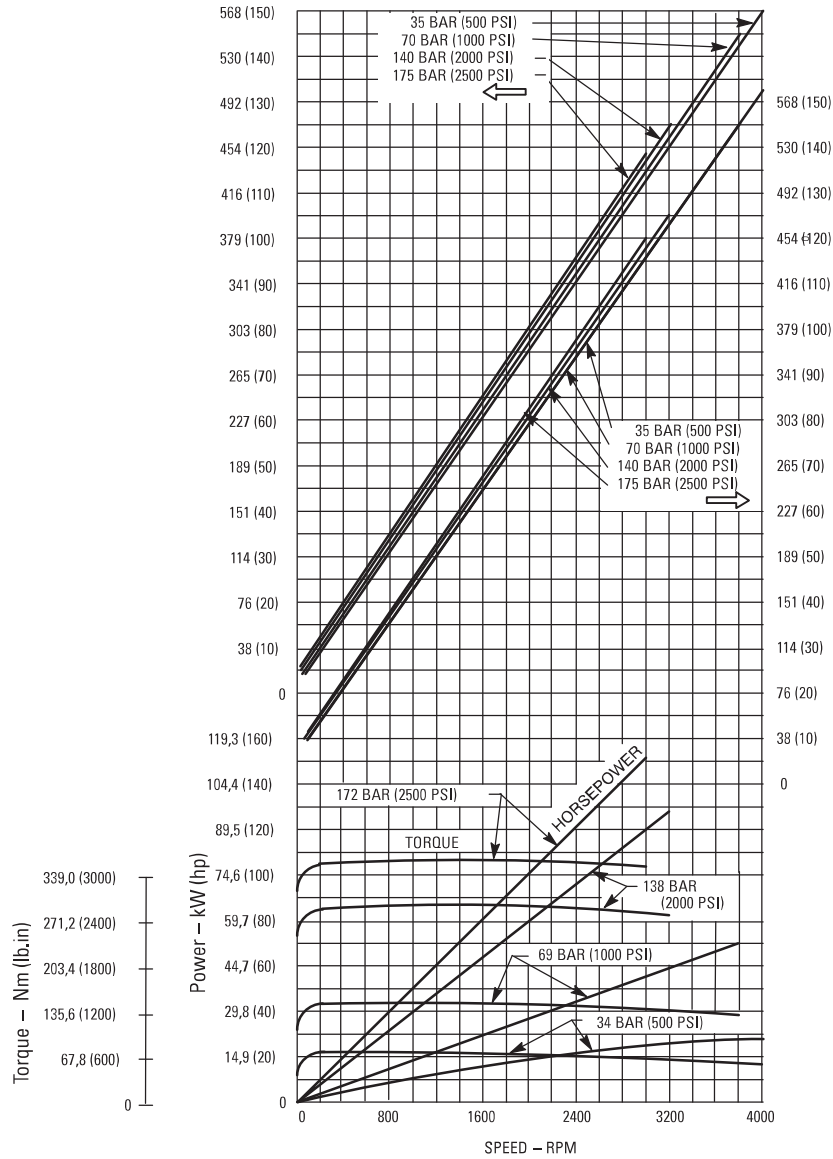

Typical Performance

45M Motors

Performance Constants:

Oil SAE 10W, viscosity 32 cSt (150 SUS) @ 38° C (100° F)

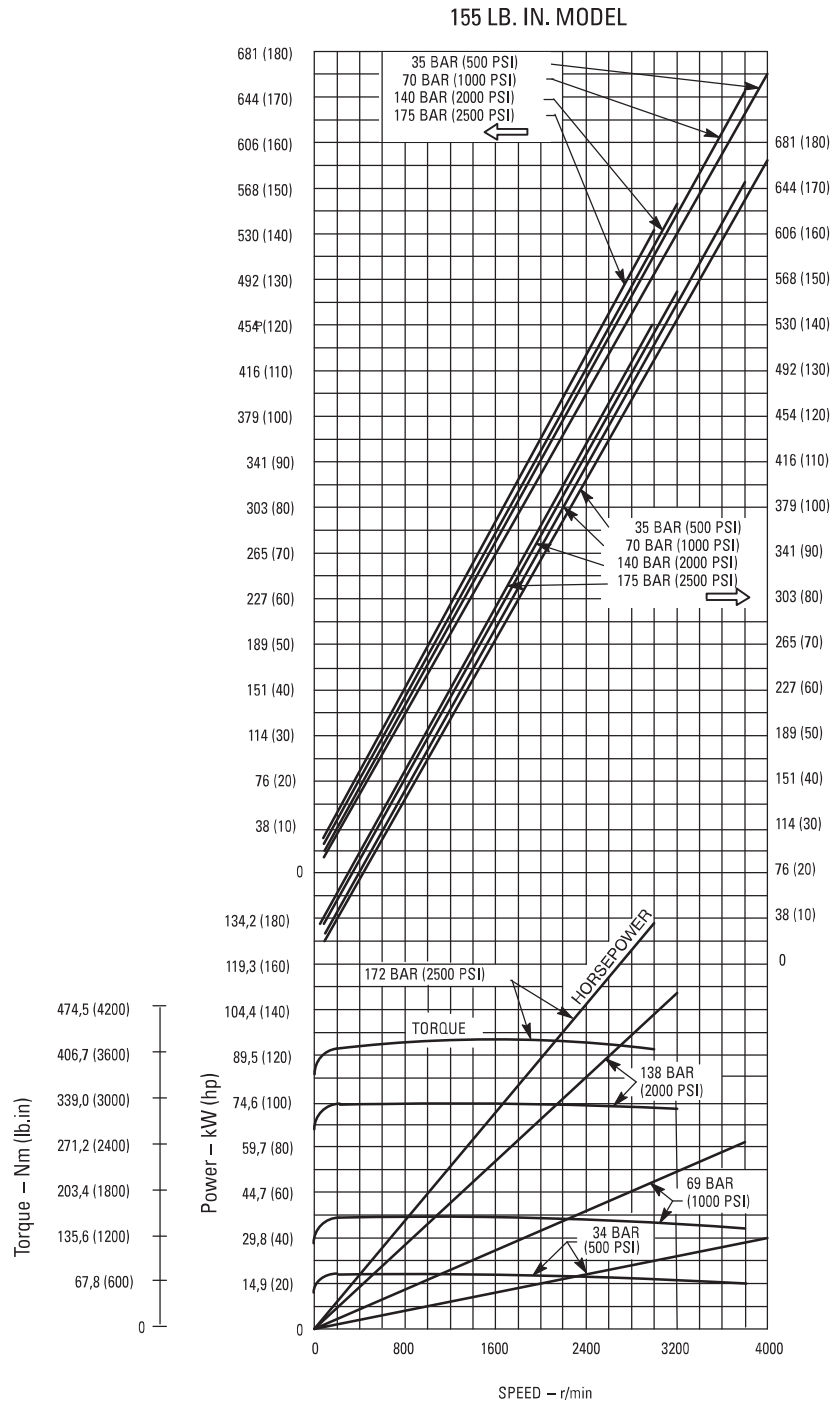

45M Motors

Performance Constants:
 Oil SAE 10W, viscosity 32 cSt (150 SUS)
 @ 38° C (100° F)

185 LB. IN. MODEL

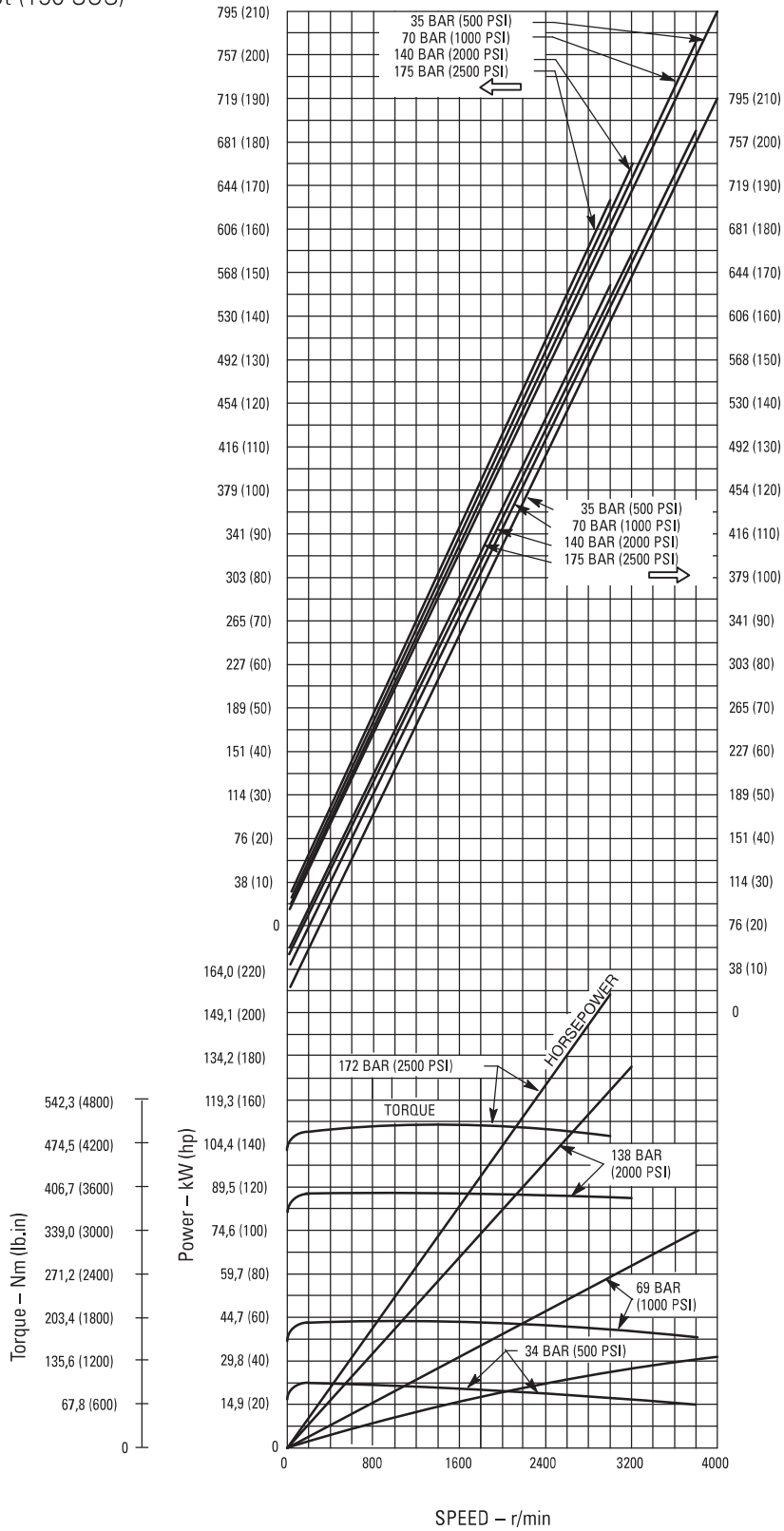

Typical Performance

50M Motors

Performance Constants:

Oil SAE 10W, viscosity 32 cSt (150 SUS) @ 38° C (100° F)

255 LB. IN. MODEL

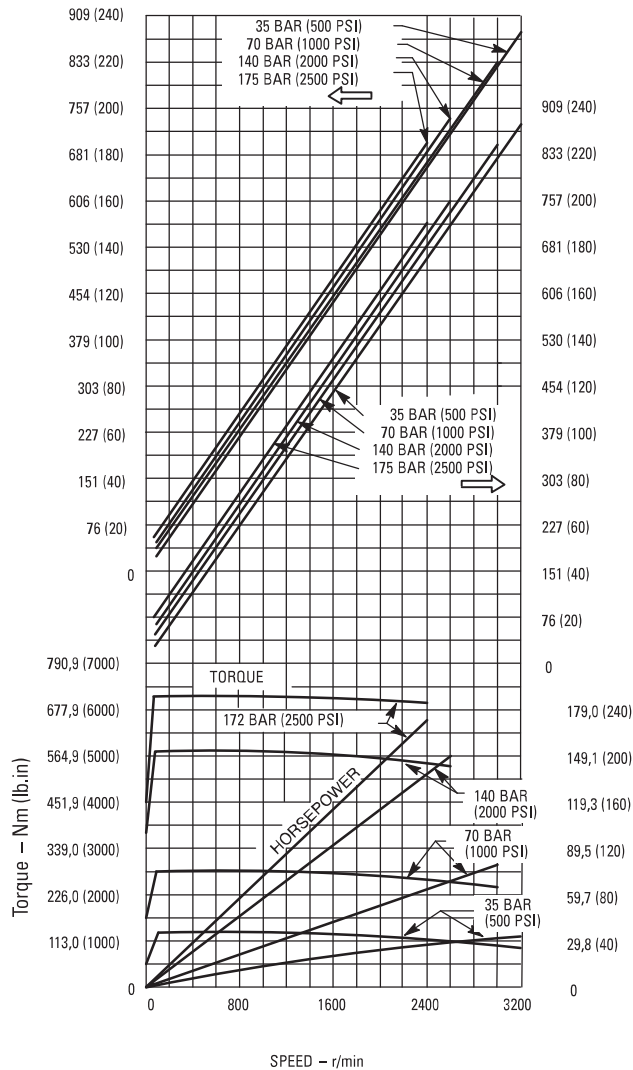

220 LB. IN. MODEL

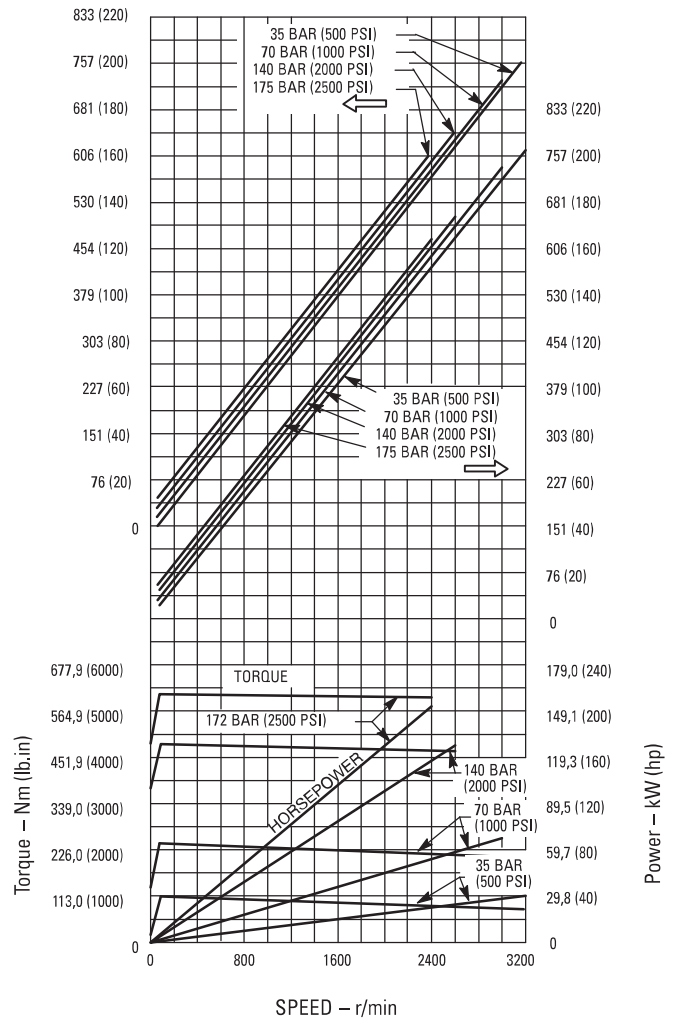

50M Motors

Performance Constants:

Oil SAE 10W, viscosity 32 cSt (150 SUS) @ 38° C (100° F)

300 LB. IN. MODEL

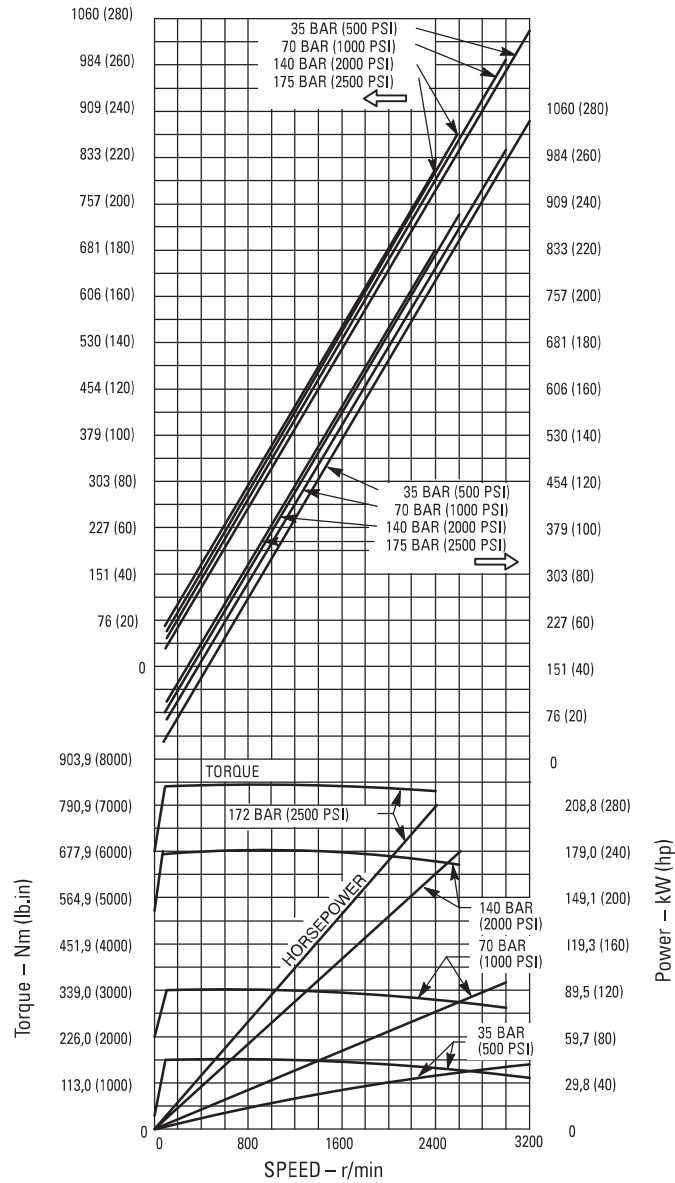

Foot Mounts

Foot bracket kits can be used to mount pumps or motors having standard SAE-J 744 2-bolt A, B, or C mounting flanges. These designations correspond to -A-, -B-, and -C- letters in the kit model number. Each kit includes a bracket and screws

for mounting to the pump or motor. Kits are not included with pumps and motors and must be ordered separately by model number.

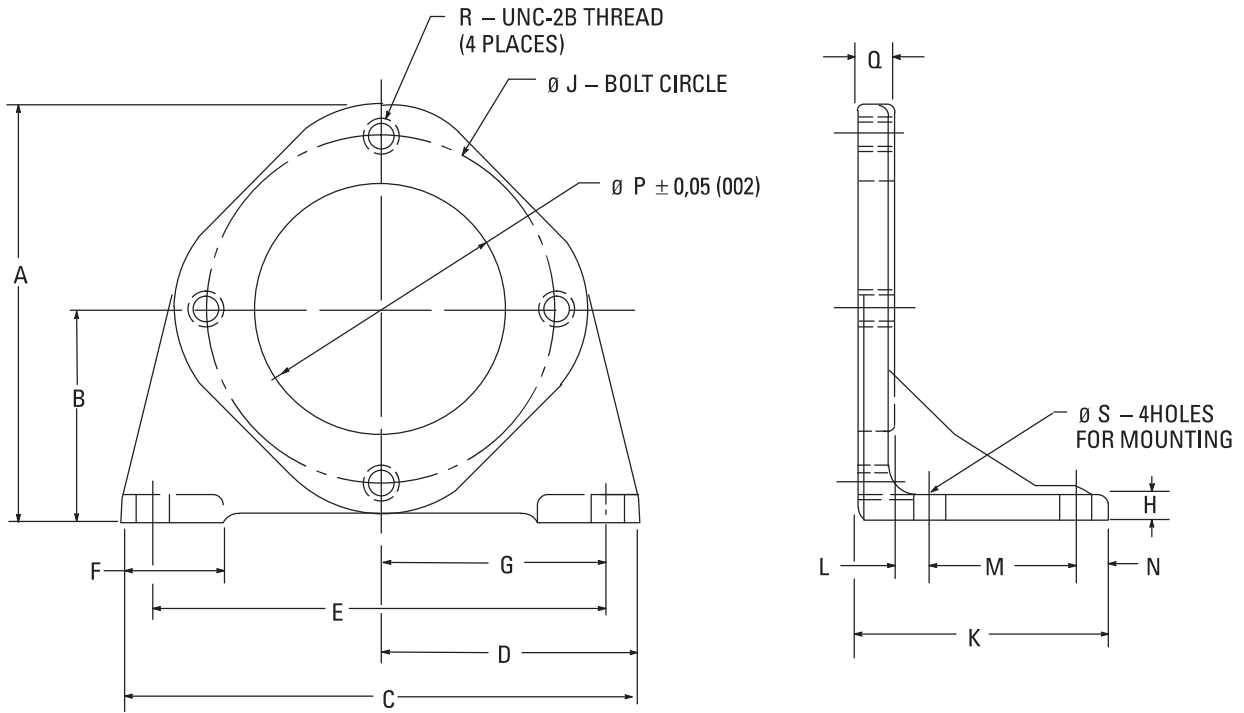

Model number	Dimensions – mm (in.)		C	D	E	F	G	H
	A	B						
FB-A-10	134,9 (5.31)	69,9 (2.75)	152,4 (6.00)	76,2 (3.00)	127,0 (5.00)	36,6 (1.44)	63,5 (2.50)	12,7 (.50)
FB-B-10	180,8 (7.12)	92,2 (3.63)	171,5 (6.75)	85,8 (3.38)	146,0 (5.75)	36,6 (1.44)	73,2 (2.88)	12,7 (.50)
FB-C-10	215,9 (8.50)	109,5 (4.31)	265,2 (10.44)	132,6 (5.22)	235,0 (9.25)	50,8 (2.00)	117,6 (4.63)	15,7 (.62)

Model number	Dimensions – mm (in.)		L	M	N	P	Q	R	S
	J	K							
FB-A-10	106,4 (4.19)	96,0 (3.78)	15,0 (.59)	50,8 (2.00)	12,7 (.50)	82,6 (3.25)	17,5 (.69)	.38-16	11,2 (.44)
FB-B-10	146,0 (5.75)	95,8 (3.77)	15,0 (.59)	50,8 (2.00)	12,7 (.50)	101,6 (4.00)	17,3 (.68)	.50-13	17,3 (.68)
FB-C-10	181,1 (7.13)	131,6 (5.18)	19,1 (.75)	76,2 (3.00)	17,3 (.68)	127,0 (5.00)	19,1 (.75)	.62-11	17,3 (.68)

Filler/Breather Unit

SP-113-C

Dimensions in millimeters (inches)

General Usage:

As a filler cap and air filter for hydraulic reservoirs.

Provides protected air vent opening, dirt screen and air filter.

Cover attached to neck of filter by means of a safety chain.

Prevents cap being lost or misplaced.

Pressure Drop VS. Oil Flow Into/Out of Reservoir

L/min (USgpm)	Pressure Drop (Inches Hg)
57 (15)	.25
76 (20)	.50
91 (24)	.75
102 (27)	1.00

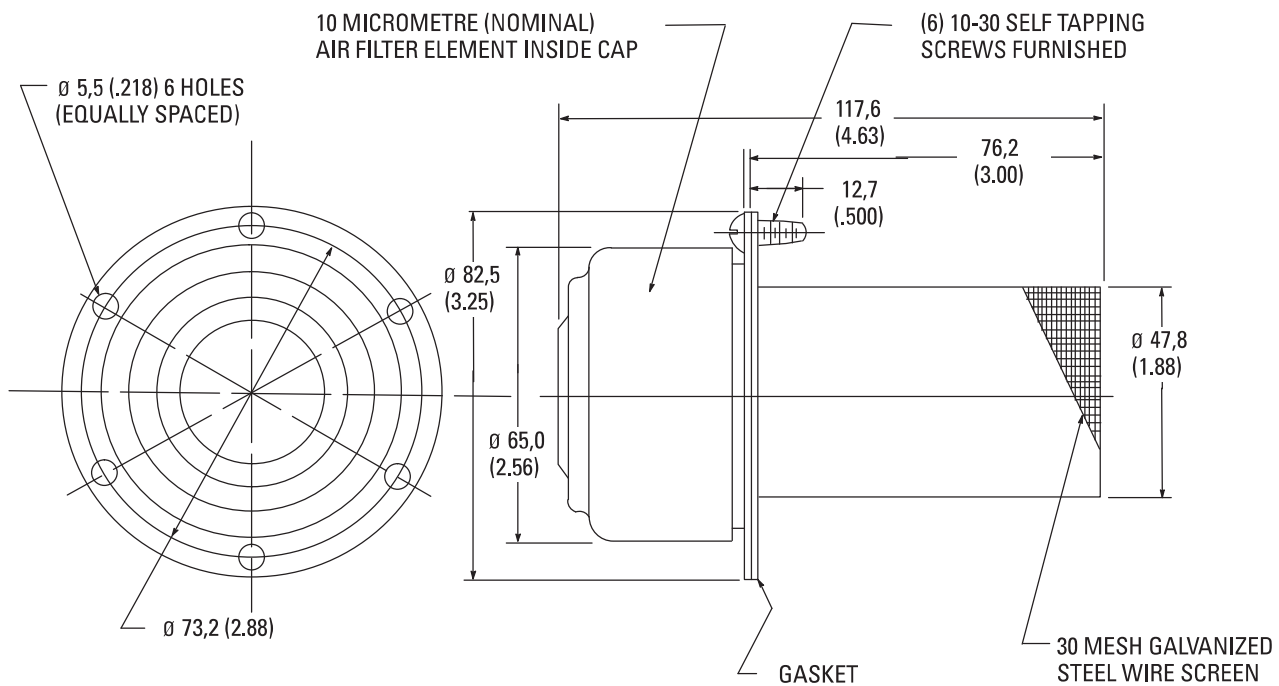

SAE 4-bolt Solid Flanges

Threaded Connection

Dimensions in millimeters (inches)

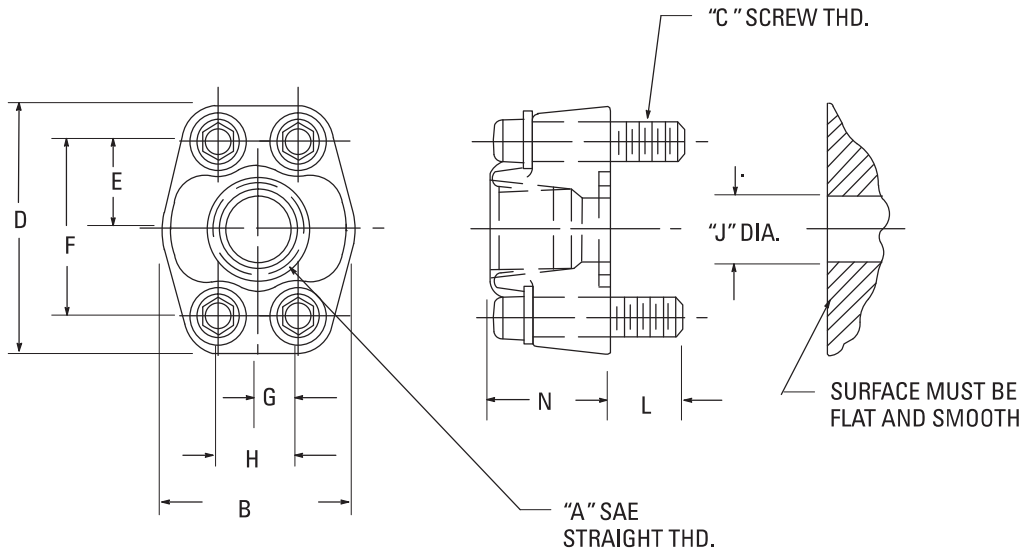

Model	Assembly	A SAE Straight Thread	B	C	D	E	F	G	H	J	L	N
FLI-6-12S-10	683829	1,0625-12 (3/4" tube)	52,3 (2,06)	3/8-16	65,0 (2,56)	23,9 (,94)	47,8 (1,88)	11,2 (,44)	22,4 (,88)	19,0 (,75)	13,5 (,53)	31,8 (1,25)
FLI-8-16S-10	683830	1,3125-12 (1" tube)	58,7 (2,31)	3/8-16	69,8 (2,75)	26,2 (1,03)	52,4 (2,06)	13,1 (,52)	26,2 (1,03)	25,4 (1,00)	16,8 (,66)	35,0 (1,38)
FL1-1 0-20S-10	683831	1,625-12 (1-1/4" tube)	73,1 (2,88)	7/16-14	79,2 (3,12)	29,4 (1,16)	58,7 (2,31)	15,1 (,59)	30,2 (1,19)	31,8 (1,25)	21,3 (,84)	38,1 (1,50)
FLI-12-24S-10	683832	1,875-12 (1-1/2" tube)	82,6 (3,25)	1/2-13	93,7 (3,69)	35,0 (1,38)	69,8 (2,75)	17,8 (,70)	35,7 (1,41)	38,1 (1,50)	18,5 (,73)	41,1 (1,62)

Oil Recommendations

The oil in a hydraulic system serves as the power transmission medium. It is also the system's lubricant and coolant. Selection of the proper oil is a requirement for satisfactory system performance and life.

The following recommendations will assist in the selection of suitable oils for use with Vickers products. Vickers does not publish a recommended oil list by brand name or supplier due to the extremely wide variety of oil types on the market.

In most cases, use of these recommendations will lead to selection of a suitable oil. However, due to the complex nature of oil formulation, the variety of oils available and peculiarities of individual hydraulic applications, there will be rare instances where oil selected on the basis of these recommendations will yield unsatisfactory results. Vickers cannot be responsible for such exceptions. In this respect, the customer is encouraged to consult his Vickers representative when selecting an oil.

Important Factors In Selecting An Oil Additives –

Hydraulic fluids contain a number of additive agents which materially improve various characteristics of oil for hydraulic systems. These additives are selected to reduce wear, increase chemical stability, inhibit corrosion and depress the pour point.

Pump performance and reliability are directly affected by the antiwear additive formulation contained in the oil. Oils providing a high level of antiwear protection are recommended for optimum performance and long life.

Viscosity –

Viscosity is the measure of fluidity. The oil selected must have proper viscosity to maintain an adequate lubricating film at system operating temperature.

In addition to dynamic lubricating properties, oil must have sufficient body to provide an adequate sealing effect between working parts of pumps, valves, cylinders and motors, but not enough to cause pump cavitation or sluggish valve action.

Optimum operating viscosity of the oil should be between 16 cSt (80 SUS) and 40 cSt (180 SUS).

"Viscosity index" reflects the way viscosity changes with temperature; the smaller the viscosity change, the higher the viscosity index. The viscosity index of hydraulic system oil should not be less than 90. Multiple viscosity oils, such as SAE 10W30, incorporate additives to improve viscosity index (polymer thickened). Oils of this type generally exhibit both a temporary and permanent decrease in viscosity due to oil shear encountered in the operating hydraulic system. The actual viscosity can, therefore, be far less in the operating hydraulic system than what is shown in normal oil data. Accordingly, when such oils are selected, it is necessary to use those with high shear stability to ensure that viscosity remains within recommended limits while in service.

Chemical Stability –

Oxidative and thermal stability are essential characteristics of oils for Mobile hydraulic systems. The combination of base

stocks and additives should be stable during the expected lifetime of the oil when exposed to the environment of these systems.

Suitable Types Of Oil

Crankcase Oil –

Crankcase oil having letter designation SC, SD, SE or SF per SAE J183 Feb '80. Note that one oil may meet one or more of these designations.

Antiwear Hydraulic Oil –

These are produced by all major oil suppliers and should consist of good quality base stocks compounded with antiwear, anti-oxidation, and antirust additives.

Due to the large number of different antiwear hydraulic oils, it is impossible for Vickers to test its products with all of them and recommend those that are suitable. Because of this, an evaluation procedure was developed for fluid suppliers to establish the suitability of their products for use in Vickers components. Publication M-2952-S, "Pump Test Procedure for Evaluation of Antiwear Hydraulic Fluids for Mobile Systems," which gives the details of this test procedure, is available on request.

Certain Other Types Of

Petroleum Oil –

Other oils are suitable if they meet the following provisions:

1. Contain the type and content of antiwear additives found in the above designated crankcase oils, and have passed the pump tests as given in M-2952-S.
2. Have sufficient chemical stability for Mobile Hydraulic system service.
3. Meet the viscosity recommendations shown in the following tables.

Oil Viscosity Recommendations

Crankcase Oils –

Hydraulic System Operating Temp. Range*	SAE Viscosity Designation
-23° C to 54° C (-10° F to 130° F)	5W, 5W-20, 5W-30
-18° C to 83° C (0° F to 180° F)	10W
-18° C to 99° C (0° F to 210° F)	10W-30, 10W-40
-10° C to 99° C (14° F to 210° F)	20-20W

Antiwear Hydraulic Oils

Hydraulic System Operating Temp. Range*	ISO Viscosity Grade
-21° C to 60° C (-5° F to 140° F)	22
-15° C to 77° C (5° F to 170° F)	32
-9° C to 88° C (15° F to 190° F)	46
-1° C to 99° C (30° F to 210° F)	68

* Temperatures shown are cold (ambient) start-up to maximum operating. During cold start-up, avoid high-speed operation of hydraulic components until the system is warmed up to provide adequate lubrication.

Oil Recommendations and Hydraulic Formulae

Arctic Conditions

Arctic conditions represent a specialized field where extensive use is made of heating equipment before starting. If necessary, this and judicious use of the following recommendations should be used:

1. SAE 5W or 5W-20 oil.
2. Oils specially developed for use in arctic conditions, such as synthetic hydrocarbons, esters, or mixtures of the two. Skydrol must not be used. Operating temperature should be closely monitored to avoid exceeding a temperature of 54C (130F) with any lightweight oil.

Special Requirements

When special considerations indicate a need to depart from recommended oils or operating conditions, consult your Vickers representative.

Horsepower:

$$\text{Horsepower} = \frac{\text{GPM} \times \text{PSI}}{1714}$$

Torque:

$$\text{Torque (lb.in.)} = \frac{\text{CU. IN./Rev.} \times \text{PSI}}{2 \pi}$$

$$\text{Torque (lb.in.)} = \frac{\text{HP} \times 63025}{\text{RPM}}$$

Volumetric Efficiency:

$$\text{Volumetric efficiency (pump)} = \frac{\text{OUTPUT GPM}}{\text{THEORETICAL GPM}} \times 100$$

$$\text{Volumetric efficiency (motor)} = \frac{\text{THEORETICAL GPM}}{\text{INPUT GPM}} \times 100$$

Overall Efficiency:

$$\text{Overall efficiency} = \frac{\text{OUTPUT HP}}{\text{INPUT HP}} \times 100$$

Flow:

$$\text{Flow (gpm)} = \frac{\text{CU. IN./REV.} \times \text{RPM}}{231}$$

Conversion Factors:

1 hp = 33,000 ft. lbs. per minute

1 hp = 42.4 btu per minute

1 hp = 0.746 kW/hr (kilowatt hour)

1 U.S. gallon = 231 cubic inches

Pipe volume varies as the square of the diameter; volume in gallons = $0.0034 D^2 L$

where: D = inside diameter of pipe in inches

L = length in inches

$$\text{Velocity in feet per second} = \frac{0.408 \times \text{flow (gpm)}}{D^2}$$

where: D = inside diameter of pipe in inches.

Atmospheric pressure at sea level = 14.7 psi.

Atmospheric pressure decreases approximately 0.41 psi for each 1,000 feet of elevation to 23,000 feet.

Pressure (psi) = feet head x 0.433 x specific gravity.

Specific gravity of oil is approximately 0.85.

Thermal expansion of oil is about 1 cu. in. per 1 gallon per 10° F rise in temperature.

Flow Capacities of Piping

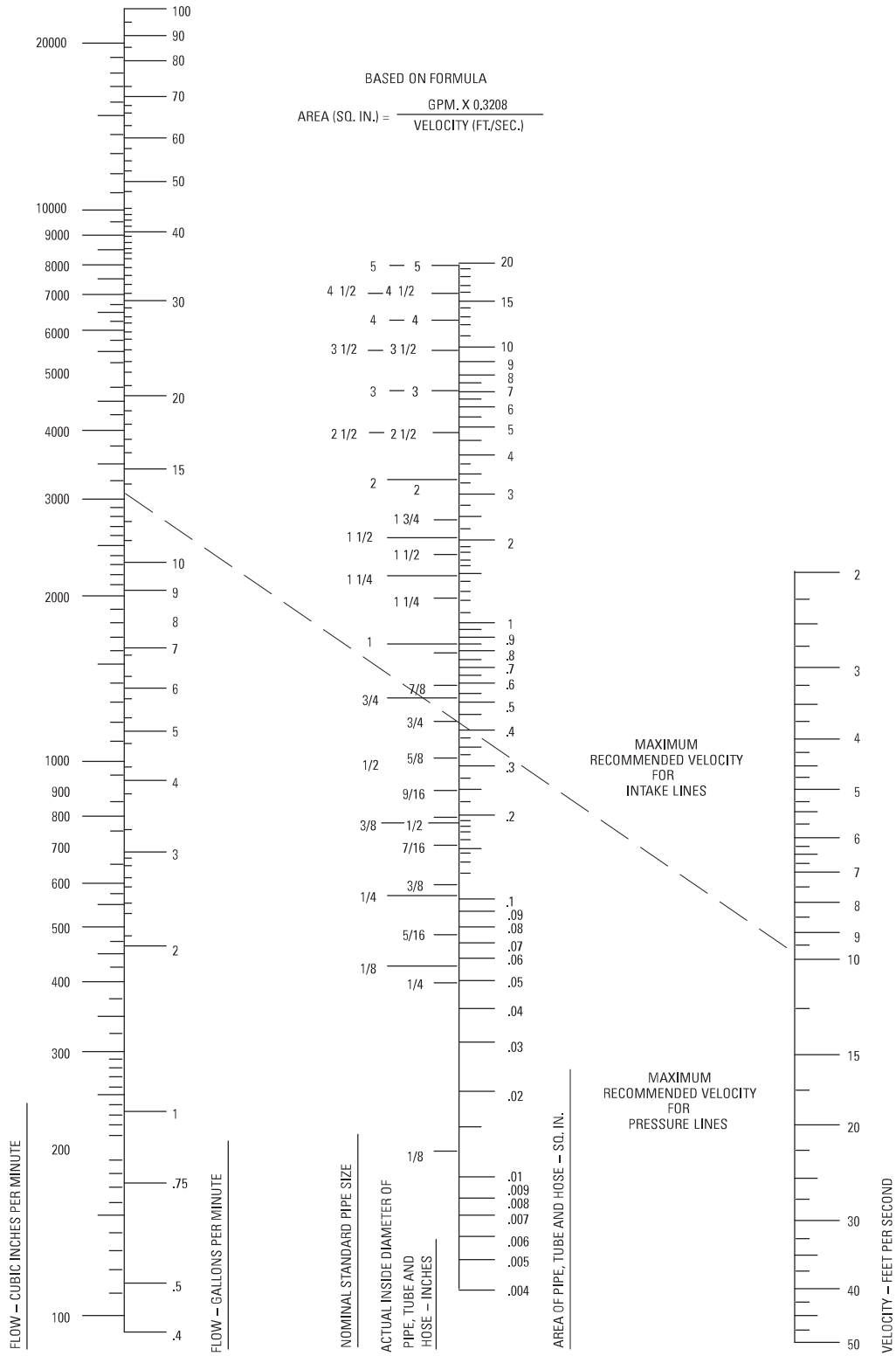

CENTRALA ELBLĄG

Ul. Rawska 19B
82-300 Elbląg

tel. /+48/ 55 625 51 00

fax /+48/ 55 625 51 01

Dział Handlowy

tel. /+48/ 55 625 51 51

elblag@hydropress.pl



www.hydropress.pl

ODDZIAŁ GDAŃSK

tel. /+48/ 55 625 51 21

fax /+48/ 55 625 51 22

ODDZIAŁ RUMIA

tel. /+48/ 58 679 34 15

fax /+48/ 55 625 51 25

ODDZIAŁ TYCHY

tel. /+48/ 32 787 52 88

fax /+48/ 55 625 51 38

ODDZIAŁ OLSZTYN

tel. /+48/ 89 532 01 05

fax /+48/ 89 715 21 42

ODDZIAŁ WARSZAWA

tel. /+48/ 22 468 86 97

fax /+48/ 55 625 51 32

BIURO WE WROCŁAWIU

tel. /+48/ 782 838 000

fax /+48/ 55 625 51 35

BIURO W KIELCACH

tel. /+48/ 885 995 501

fax /+48/ 55 625 51 01

BIURO W KRAKOWIE

tel. /+48/ 885 995 019

fax /+48/ 55 625 51 01

BIURO W OPOLU

tel. /+48/ 885 995 011

fax /+48/ 55 625 51 01

BIURO W BYDGOSZCZY

tel. /+48/ 790 222 771

fax /+48/ 55 625 51 01

BIURO W BIAŁYMSTOKU

tel. /+48/ 89 532 01 05

fax /+48/ 89 715 21 42

BIURO W ŁODZI

tel. /+48/ 609 221 421

fax /+48/ 89 715 21 42