



# POMPY TŁOCZKOWE DLA OBIEGU OTWARTEGO

Eaton PVB - pompy tłoczkowe  
o zmiennej wydajności

# Contents

---

Basic characteristics	A.3
General Description	A.3
Functional symbols	A.3
Model Codes	A.4
Operating data	A.5
Minimum Inlet Pressure Curves	A.5–A.6
Performance data @ 1500 r/min drive speed:	
PFB5, PFB10, PFB20	A.7
PVB5, PVB6, PVB10	A.8
PVB15, PVB20, PVB29	A.9
PVB45, PVB90	A.10
Performance data @ 1800 r/min drive speed:	
PFB5, PFB10, PFB20	A.11
PVB5, PVB6, PVB10	A.12
PVB15, PVB20, PVB29	A.13
PVB45, PVB90	A.14
Control data for PVB pumps	A.15
Noise levels	A.16
Installation data	
PFB5 SAE flange mounting	A.17
PFB10 SAE flange mounting	A.18
PFB20 SAE flange mounting	A.19
PVB5/6 SAE flange mounting C & CM pressure compensator controls	A.20
PVB5/6 side ported thru shaft	A.21
PVB10/15 SAE flange mounting C & CM pressure compensator control	A.22
PVB10/15 side ported thru shaft	A.23
PVB5/6 & PVB10/15 M lever control, & H handwheel control	A.24
PVB20/29 SAE flange mounting C & CM pressure compensator control	A.25
PVB20/29 side ported thru shaft	A.26
PVB45 flanged mounted	A.27
PVB45 foot mounted	A.28
PVB90	A.29
PVB5/6, PVB10/15 & PVB20/29 CC & CMC pressure compensator and adjustable maximum displacement stop	A.30
PVB5 – 29 CG Remote control compensator, CVP Load sensing & –S30 drain port option	A.31
PVB5/6, PVB10/15, PVB20/29 DIN/ISO models	A.32
Installation data	A.33

## Basic Characteristics

Type . . . . . Axial piston pumps  
 Operating pressure . . . . . up to 210 bar  
 (3000 psi)  
 Displacement . . . . . 10,5 to 197,5 cm<sup>3</sup>/r  
 (0.64 to 12 in<sup>3</sup>/r)  
 Drive speed . . . . . up to 3600 r/min

## Typical Section

Variable displacement model with compensator control "C" or "CM"

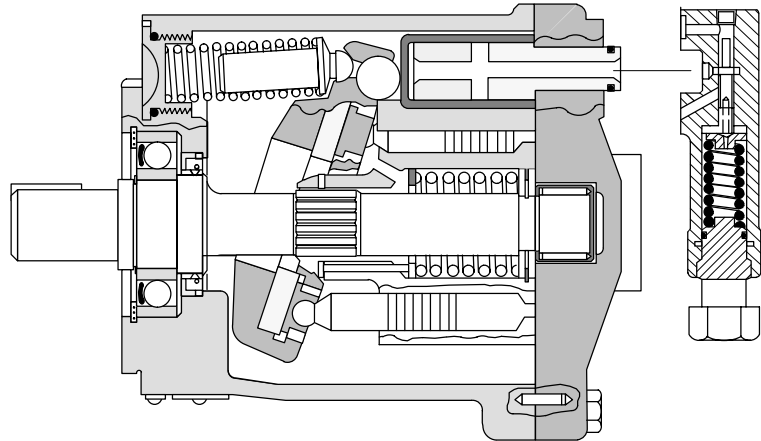

## General Description

Both fixed and variable displacement models make up this range of axial piston pumps. Their high performance ratings and efficiencies are achieved with a variety of hydraulic fluids. Fixed displacement models are noted for their volumetric and mechanical efficiencies. Variable displacement models can closely match pressure and/or flow demand with a control selected from:

- Pressure compensator with or without a remote control facility.
- Pressure compensator with adjustable displacement control.
- Load sensing compensator.
- Mechanical (lever) control.
- Handwheel control

## Functional Symbols

**PFB**  
 Fixed displacement models

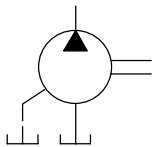

**PVB**  
 Variable displacement models

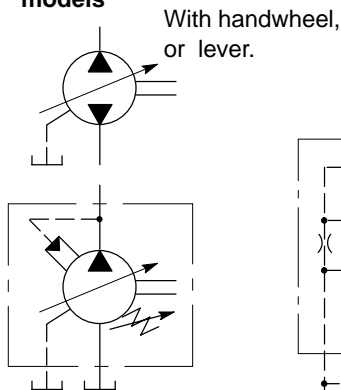

With pressure compensator (C or CM) (simplified symbol)

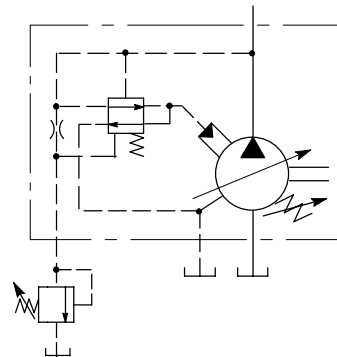

With pressure compensator arranged for remote control C(M)G (detailed symbol)

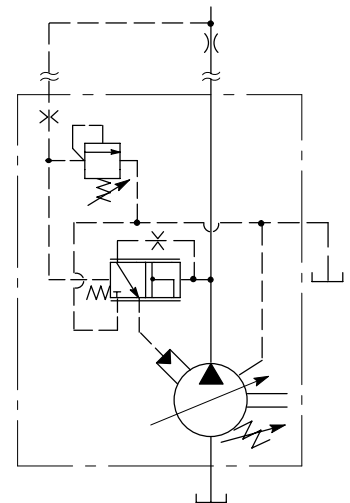

With CVP load sensing and pressure limiter

# Model Codes

**P \* B \*\* - (F) - (M) \* \* (F)(X) (\*) - \*\* - \*\* - (C) - (G) - (L) - \*\* - \*\*\*\***

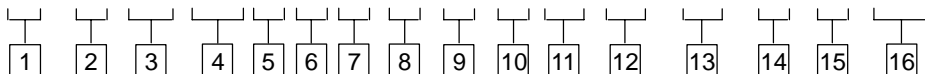

## 1 Basic models

F = Fixed displacement type  
V = Variable displacement type

## 2 Displacement

PFB and PVB models:

5 = 10,55 cm<sup>3</sup>/r (0.64 in<sup>3</sup>/r)  
10 = 21,10 cm<sup>3</sup>/r (1.29 in<sup>3</sup>/r)  
20 = 42,80 cm<sup>3</sup>/r (2.61 in<sup>3</sup>/r)

PVB models only:

6 = 13,81 cm<sup>3</sup>/r (0.84 in<sup>3</sup>/r)  
15 = 33,00 cm<sup>3</sup>/r (2.01 in<sup>3</sup>/r)  
29 = 61,60 cm<sup>3</sup>/r (3.76 in<sup>3</sup>/r)  
45 = 94,50 cm<sup>3</sup>/r (5.76 in<sup>3</sup>/r)  
90 = 197,50 cm<sup>3</sup>/r (12.0 in<sup>3</sup>/r)

## 3 Foot mounting option

F = Foot mounting option for PVB45 and PVB90 models.

Omit for flange mounting.

**Note.** For foot mounting brackets. for other models see bottom of page.

## 4 Mounting flange

M = Metric, to DIN/ISO 3019, Part 2 and VDMA 24560, Part 1

Omit for SAE mounting flange

## 5 Shaft rotation

Viewed at shaft end

R = Clockwise

L = Anticlockwise (not available for PFB10 and PFB20)

## 6 Displacement zone

PVB models only.

S = One side of center (pressure compensated models only)

D = Both sides of center (Handwheel and lever controlled models only)

Omit for PFB models.

## 7 Flanged main ports

F = PVB45 and PVB90 models only.  
Omit for P\*B5 to 29 inclusive.

## 8 Thru shaft option

PVB5 to 29 only:

X = Thru shaft (with side entry ports)  
Omit for PVB45 and PVB 90, or if not required.

## 9 Shaft type

N = Metric, to DIN/ISO 3019, Part 2 and VDMA 24560, Part 1

Y = SAE models P\*B5 to 15 only.

Omit for 20 thru 90 models

## 10 Pump design number

10 = PFB20

30 = PFB10

31 = PVB10 and PVB15

20 = all other models

## 11 Displacement control options

PVB models only.

C = Pressure compensator. Pressure adjustment range:

PVB90: 19 to 210 bar (275 to 3000 psi)

All other models: 17 to 210 bar (250 to 3000 psi)

Also used as prefix for item 12

**Note.** For PVB6, 15 and 29 models, the user must ensure that the max. pressure setting never exceeds 140 or 100 bar (2000 or 1500 psi) dependent on the type of fluid being used.

CM = Pressure compensator. Option for all sizes except PVB90.

Pressure adjustment range:

PVB45: 10 to 100 bar (150 to 1500 psi)

All other sizes: (17 to 100 bar (250 to 1500 psi)

CVP = Load sensing with pressure limiter.

PVB5 to 15 only:

H = Handwheel control

M = Lever control

V = No control (As for "M" type but without lever.)

Omit for PFB models.

## 12 Maximum displacement adjustment

PVB5 to 29 models only:

C = "C" or "CM" compensator, and with 12

Omit when not required.

## 13 Pressure compensator variations

PVB5 to 29 models only:

G = Remotely adjustable pressure setting.

Omit when not required.

## 14 Control location

PVB5 to 15 models with "H", "M" or "V" controls only:

L = Left hand, when viewed at shaft end.

Omit for right hand, or when a pressure compensator is fitted.

## 15 Control design number

PVB models only.

10 = "H" and "M" controls; also "C" control for PVB90

11 = "C" and "CM" controls.

12 = "CVP" control.

20 = "CG" control.

## 16 Special design options

For PFB5 and PVB5 to 29 only:

S.30 = Extra drain port to permit vertical "shaft-up" installation.

For PVB5 to PVB29 pressure compensated models only:

GE1 = 10% minimum displacement. when pressure compensated.

For all models:

GEVS = Pressure setting knob with key lock.

Omit when not required.

## Foot bracket mounting kits

Order separately if required. Kits include pump fixing bolts.

Model code	Part number	For pump sizes:
------------	-------------	-----------------

FB-A-10	422582	P*B5/6
---------	--------	--------

FB-B-10	422583	P*B10/15 and PFB20
---------	--------	--------------------

FB-C-10	422584	PVB20/29
---------	--------	----------

# Operating Data

## Pressure and Speed Limits

Basic model designation	Geometric displacement, cm <sup>3</sup> /r (in <sup>3</sup> /r)	Maximum shaft speed (r/min)			Maximum outlet pressure, bar (psi)		
		Anti-wear hydraulic oil	Water-in-oil emulsion (40%/60%)	Water-glycol	Anti-wear hydraulic oil	Water glycol	Water-in-oil emulsion (40%/60%)
PFB5	10,55 (0.64)	3600			210 (3000)		
PFB10	21,10 (1.29)	3200	1800	1800	210 (3000)	175 (2500)	175 (2500)
PFB20	42,80 (2.61)	2400			175(2500)		
PVB5	10,55 (0.64)				210 (3000)	140 (2000)	140 (2000)
PVB6	13,81 (0.84)				140 (2000)	100 (1500)	100 (1500)
PVB10	21,10 (1.29)				210 (3000)	140 (2000)	140 (2000)
PVB15	33,00 (2.01)	1800	1800	1800	140 (2000)	100 (1500)	100 (1500)
PVB20	42,80 (2.61)				210 (3000)	140 (2000)	140 (2000)
PVB29	61,60 (3.76)				140 (2000)	100 (1500)	100 (1500)
PVB45	94,50 (5.76)				210 (3000)	140 (2000)	140 (2000)
PVB90	197,50 (12.0)	1800	1200	1200	210 (3000)	140 (2000)	140 (2000)

## Maximum Inlet Pressure

All pumps except PVB5/6/10/15 with H, M or V controls . . . . . 1,0 bar (15 psi)  
 PVB5/6/10/15 with H, M or V controls . . . . . As "Max. outlet pressure" above  
 for appropriate size.

## Case Drain Pressure

See "Installation data" section, on page A.33.

## Minimum Inlet Pressure

See following graphs.  
 Based on oil viscosity of 21 cSt (102 SUS) and at 50°C (120°F).

### PFB5 and PVB5

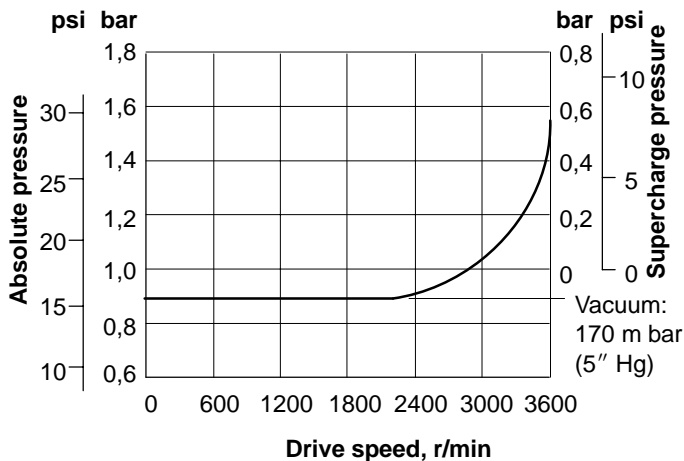

### PVB6

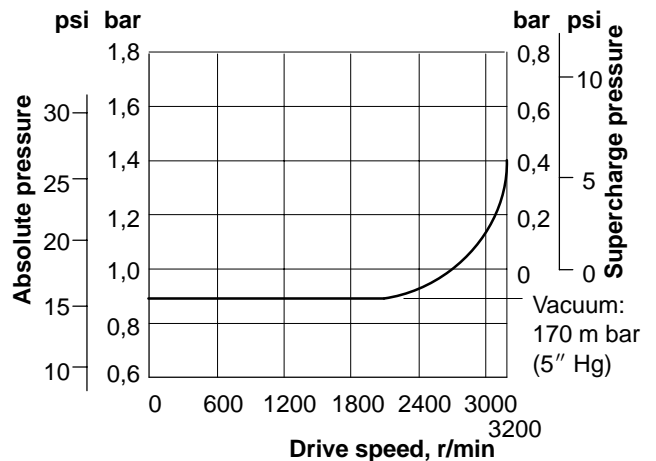

# Operating Data Minimum Inlet Pressure (cont'd)

## PFB10 and PVB10

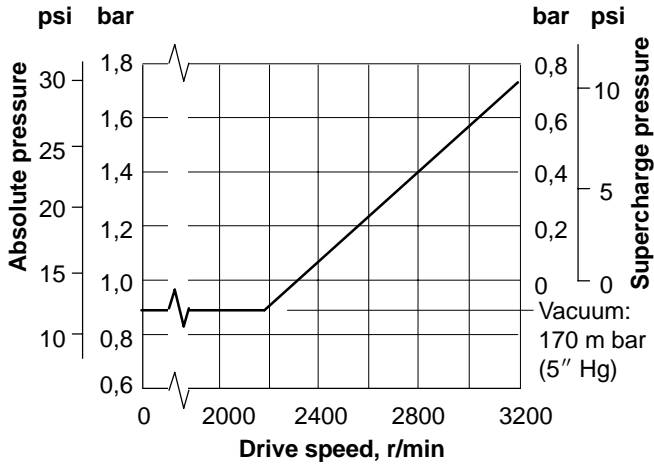

## PVB15

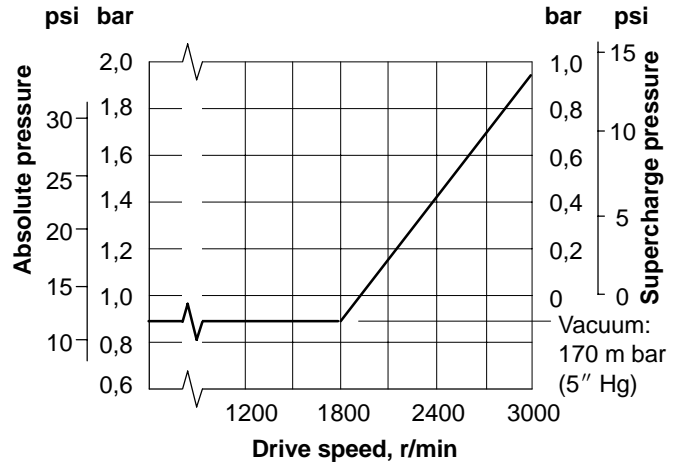

## PFB20

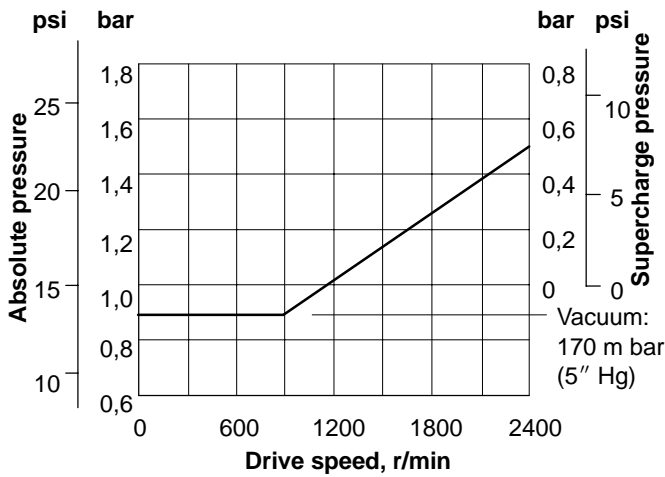

## PVB20 and PVB29

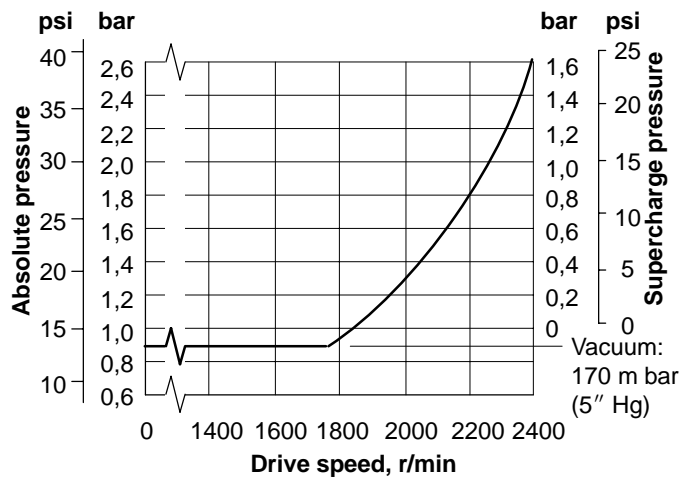

## PVB45

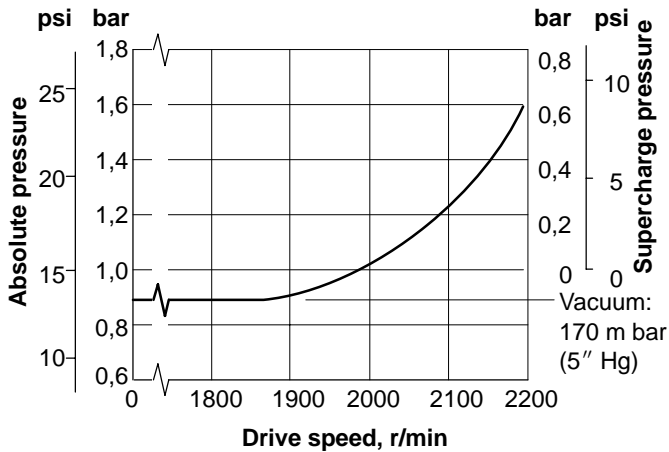

## PVB90

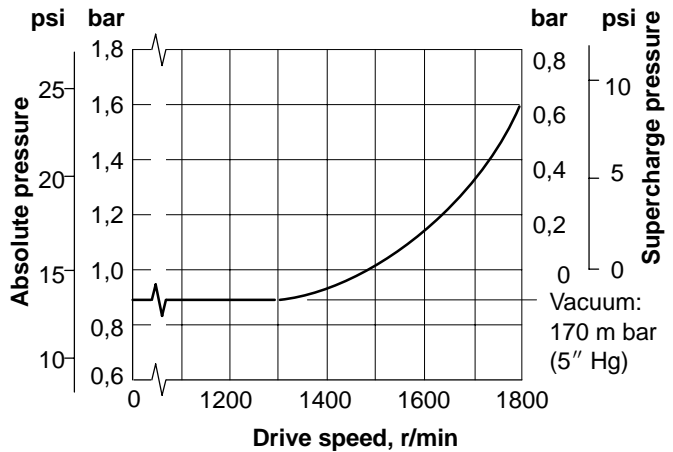

# Performance Data at 1500 r/min Drive Speed

With oil at 21cSt (102 SUS) and at 49°C (120°F): Atmospheric inlet  
 For data at drive speed of 1800 r/min, see pages A.11 to A.14

## PFB5

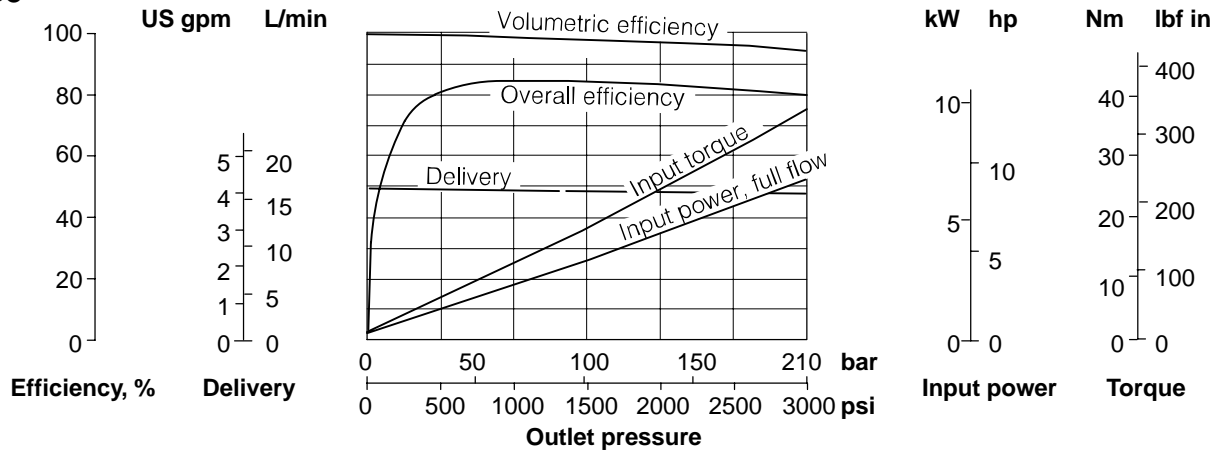

## PFB10

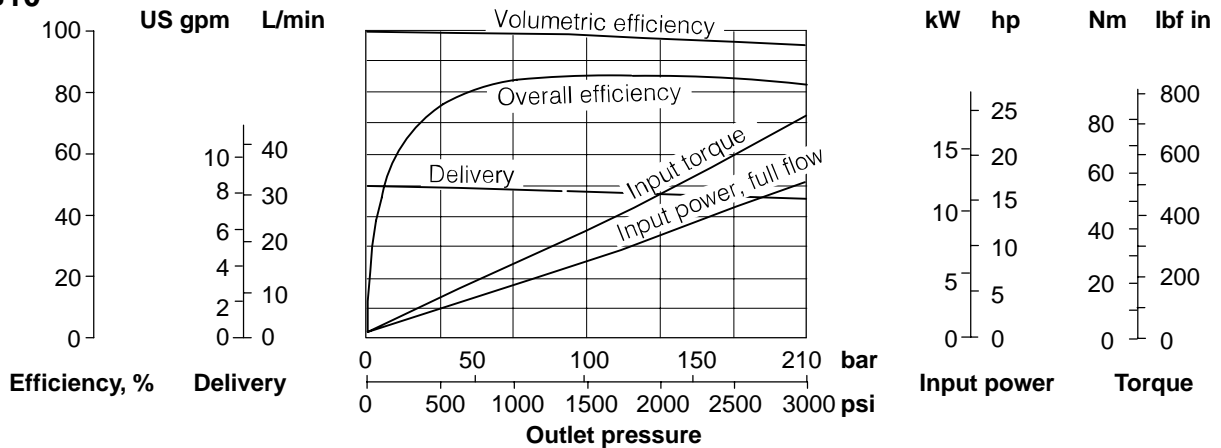

## PFB20

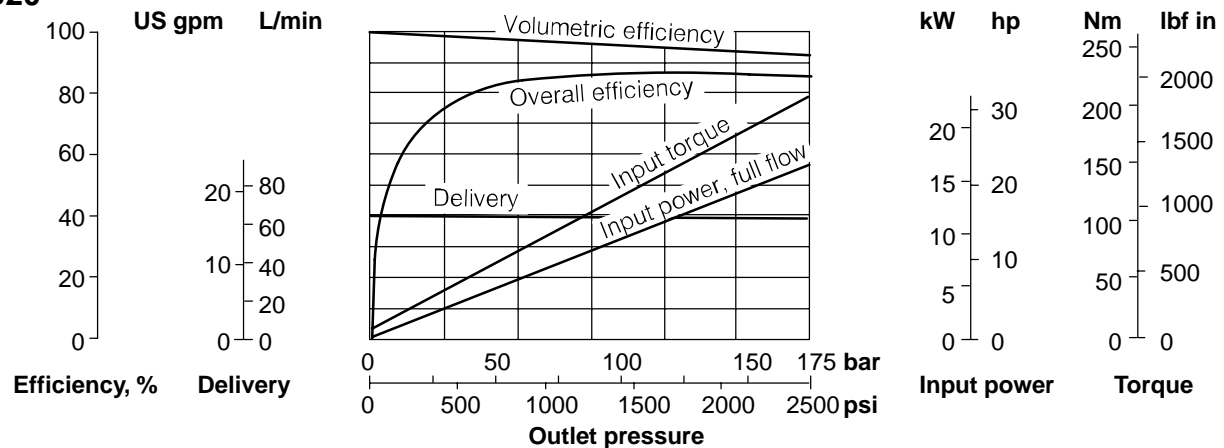

# Performance Data at 1500 r/min Drive Speed (cont'd)

With oil at 21cSt (102 SUS) and at 49°C (120°F): Atmospheric inlet  
 For data at drive speed of 1800 r/min, see pages A.11 to A.14

## PVB5

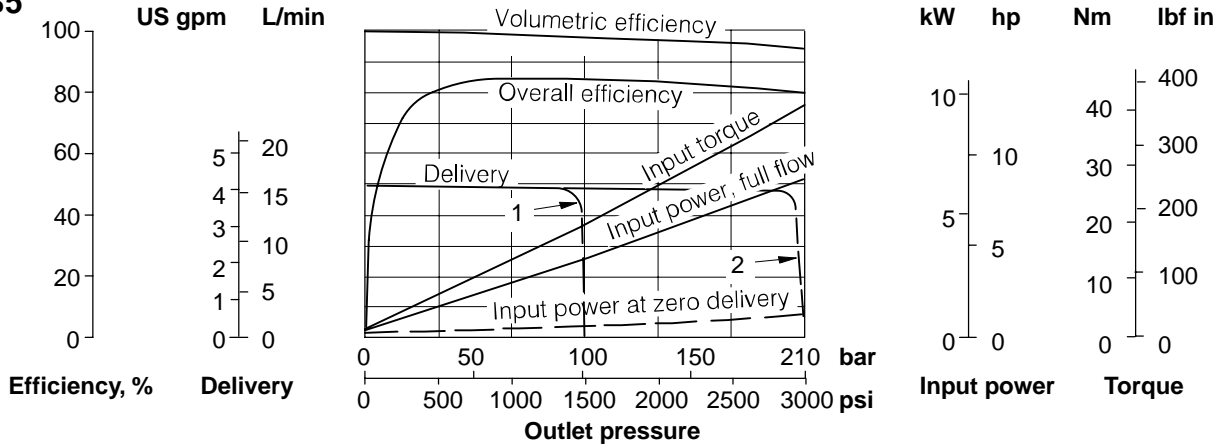

1 = Delivery with compensator setting of 100 bar (1500 psi)  
 2 = Delivery with compensator setting of 200 bar (3000 psi)

## PVB6

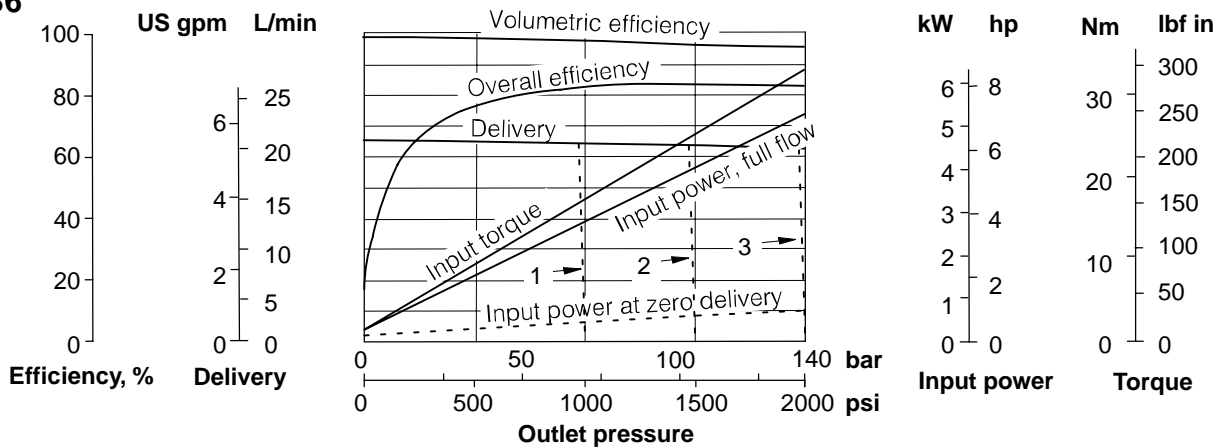

1 = Delivery with compensator setting of 70 bar (1000 psi)  
 2 = Delivery with compensator setting of 100 bar (1500 psi)  
 3 = Delivery with compensator setting of 140 bar (2000 psi)

## PVB10

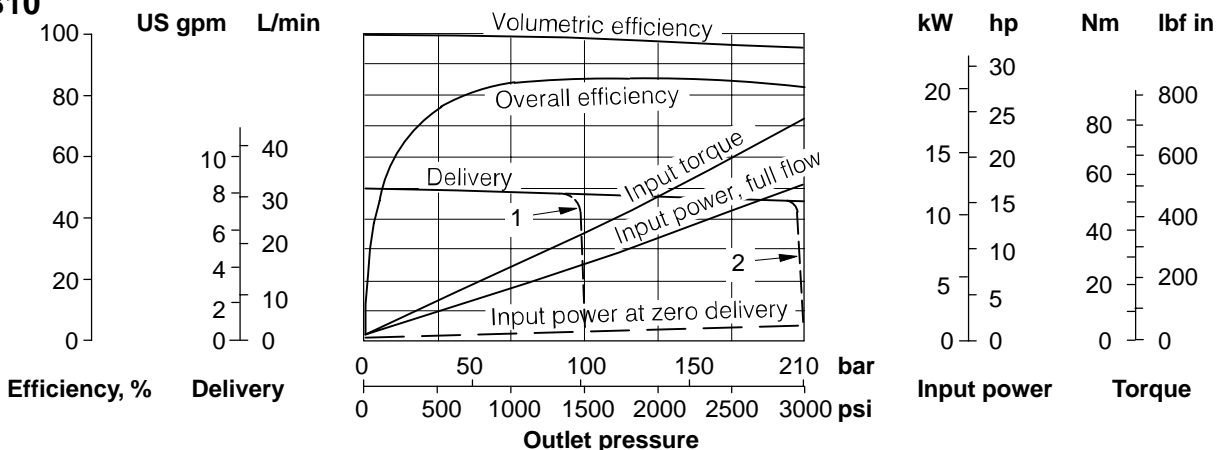

1 = Delivery with compensator setting of 100 bar (1500 psi)  
 2 = Delivery with compensator setting of 200 bar (3000 psi)



# Performance Data at 1500 r/min Drive Speed (cont'd)

With oil at 21cSt (102 SUS) and at 49°C (120°F): Atmospheric inlet  
 For data at drive speed of 1800 r/min, see pages A.11 to A.14

## PVB15

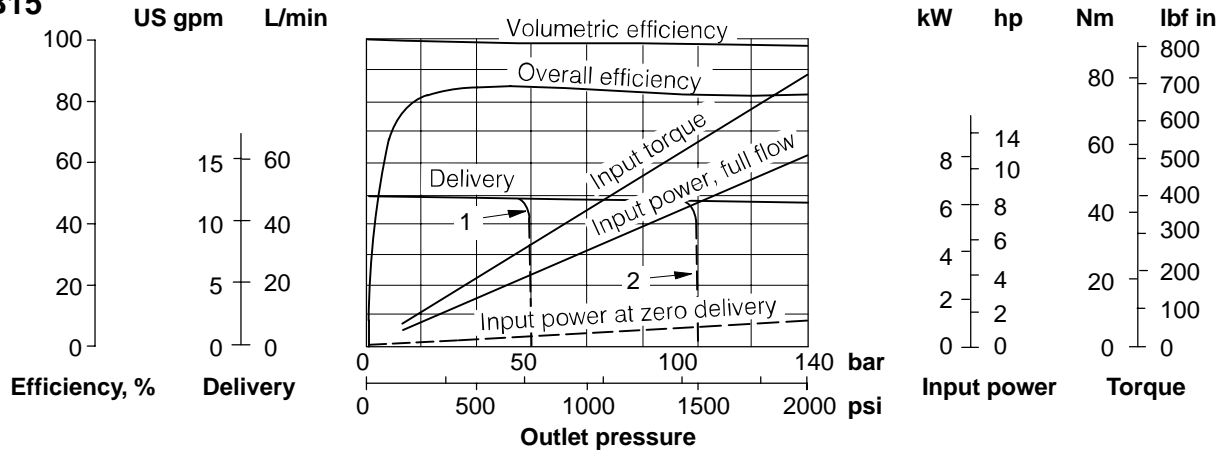

1 = Delivery with compensator setting of 50 bar (750 psi)  
 2 = Delivery with compensator setting of 100 bar (1500 psi)

## PVB20

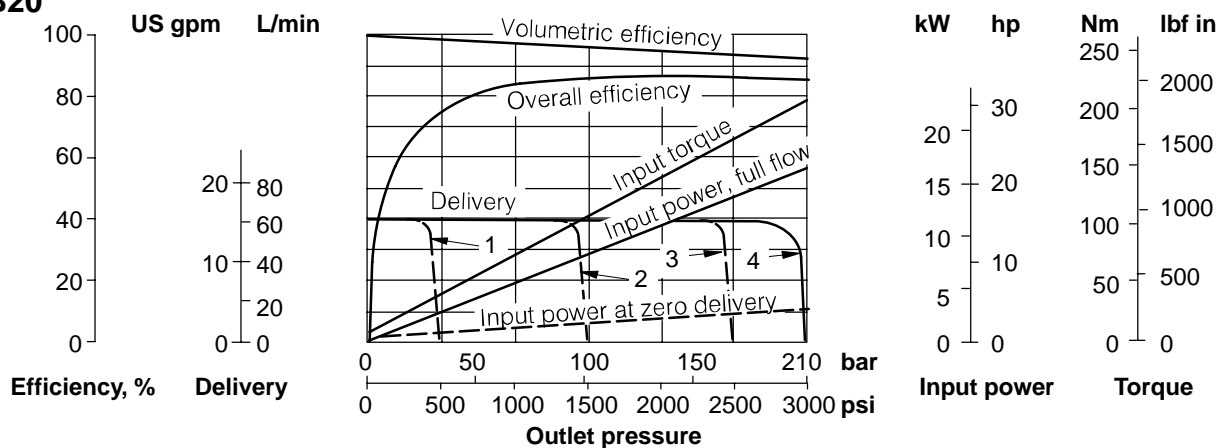

1 = Delivery with compensator setting of 35 bar (500 psi)      3 = Delivery with compensator setting of 175 bar (2500 psi)  
 2 = Delivery with compensator setting of 100 bar (1500 psi)      4 = Delivery with compensator setting of 200 bar (3000 psi)

## PVB29

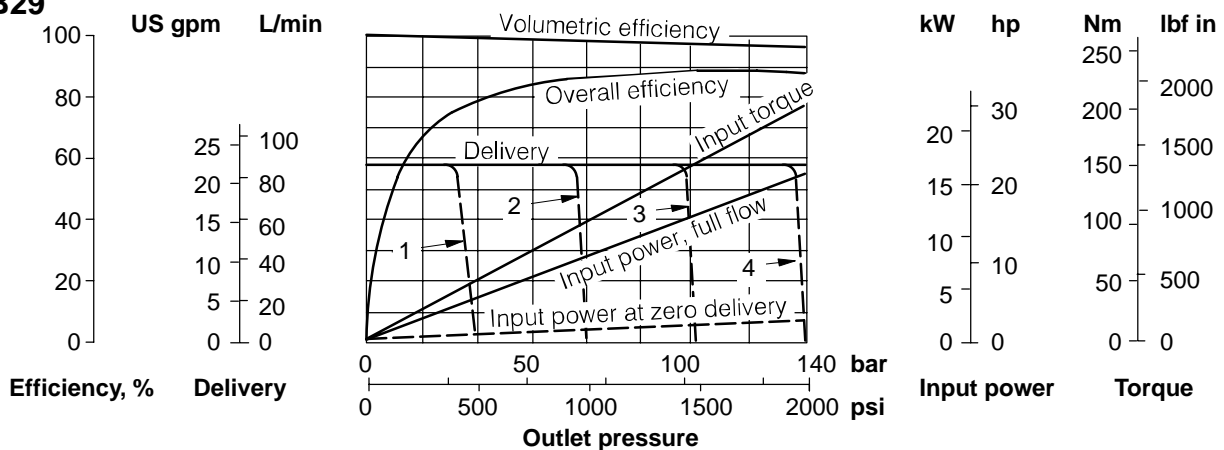

1 = Delivery with compensator setting of 35 bar (500 psi)      3 = Delivery with compensator setting of 175 bar (2500 psi)  
 2 = Delivery with compensator setting of 100 bar (1500 psi)      4 = Delivery with compensator setting of 200 bar (3000 psi)

# Performance Data at 1500 r/min Drive Speed (cont'd)

With oil at 21cSt (102 SUS) and at 49°C (120°F): Atmospheric inlet  
 For data at drive speed of 1800 r/min, see pages A.11 to A.14

## PVB45

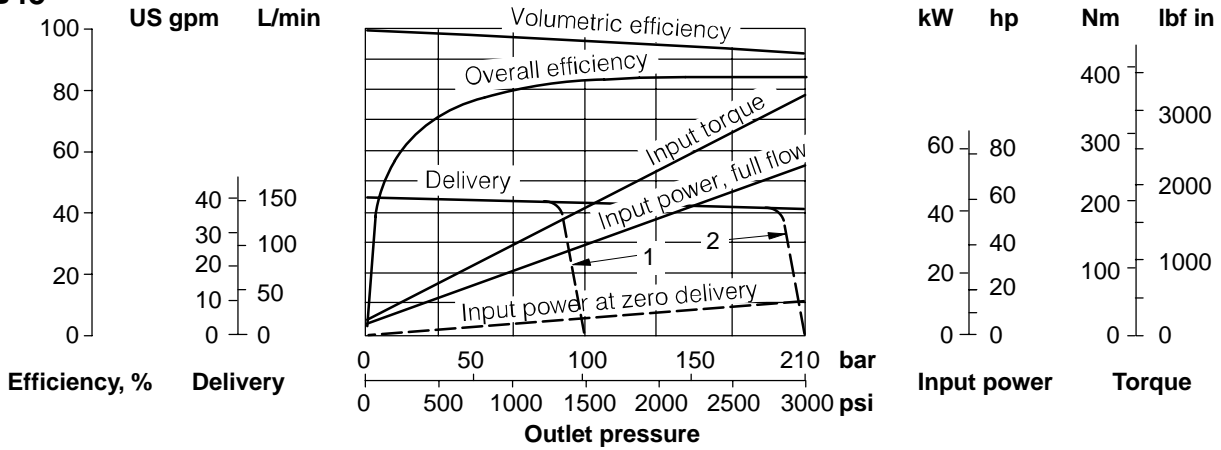

1 = Delivery with compensator setting of 100 bar (1500 psi)  
 2 = Delivery with compensator setting of 200 bar (3000 psi)

## PVB90

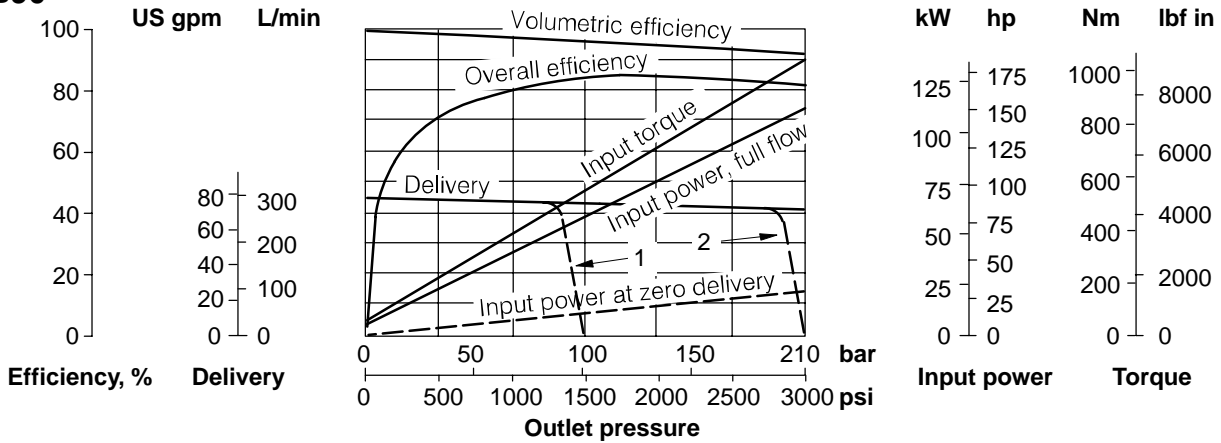

1 = Delivery with compensator setting of 100 bar (1500 psi)  
 2 = Delivery with compensator setting of 200 bar (3000 psi)

# Performance Data at 1800 r/min Drive Speed

With oil at 21cSt (102 SUS) and at 49°C (120°F): Atmospheric inlet  
 For data at drive speed of 1500 r/min, see pages A.7 to A.10

## PFB5

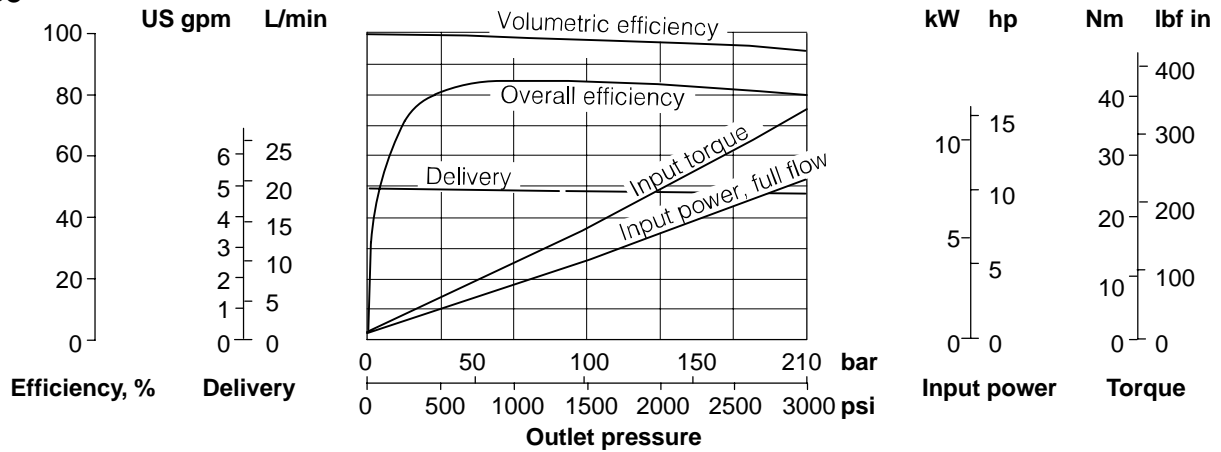

## PFB10

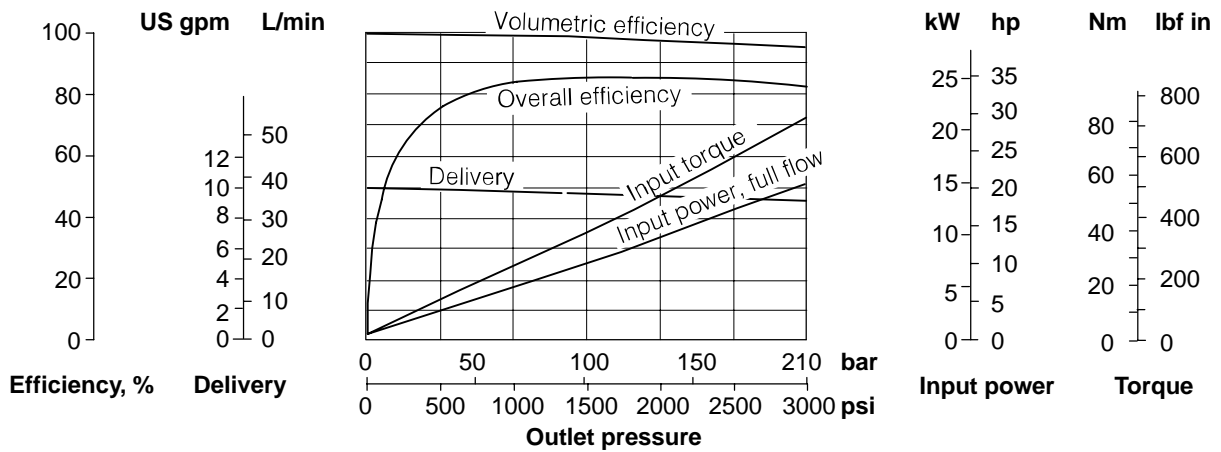

## PFB20

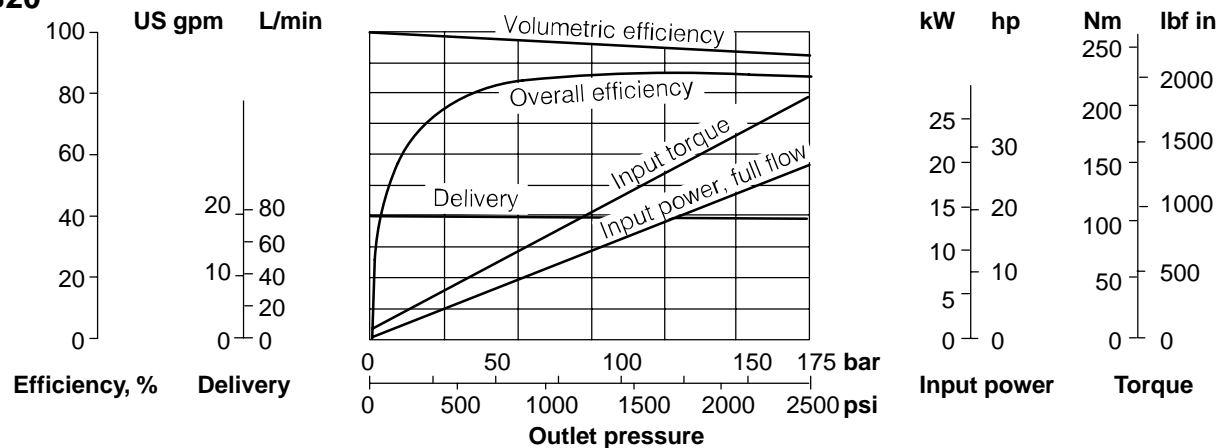

# Performance Data at 1800 r/min Drive Speed (cont'd)

With oil at 21cSt (102 SUS) and at 49°C (120°F): Atmospheric inlet  
 For data at drive speed of 1500 r/min, see pages A.7 to A.10

## PVB5

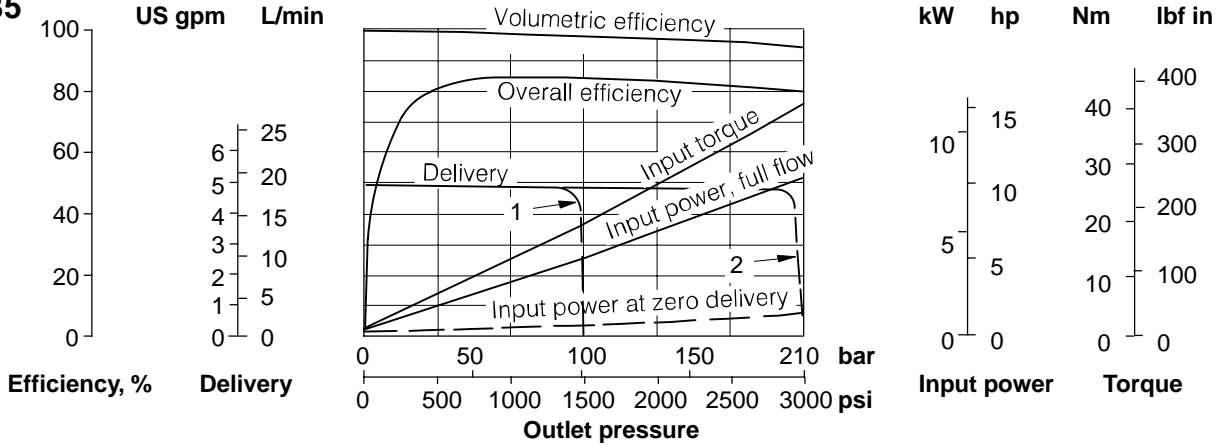

1 = Delivery with compensator setting of 100 bar (1500 psi)  
 2 = Delivery with compensator setting of 200 bar (3000 psi)

## PVB6

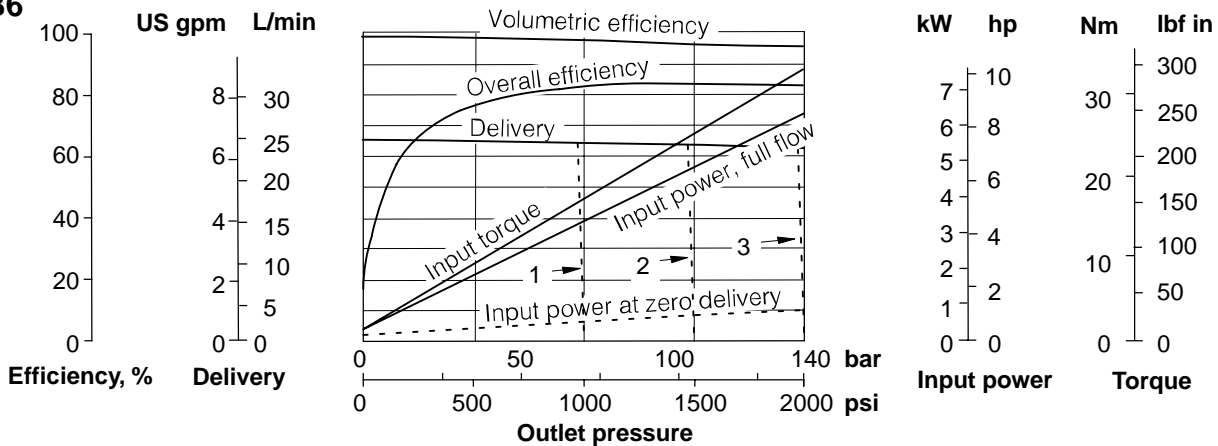

1 = Delivery with compensator setting of 70 bar (1000 psi)  
 2 = Delivery with compensator setting of 100 bar (1500 psi)  
 3 = Delivery with compensator setting of 140 bar (2000 psi)

## PVB10

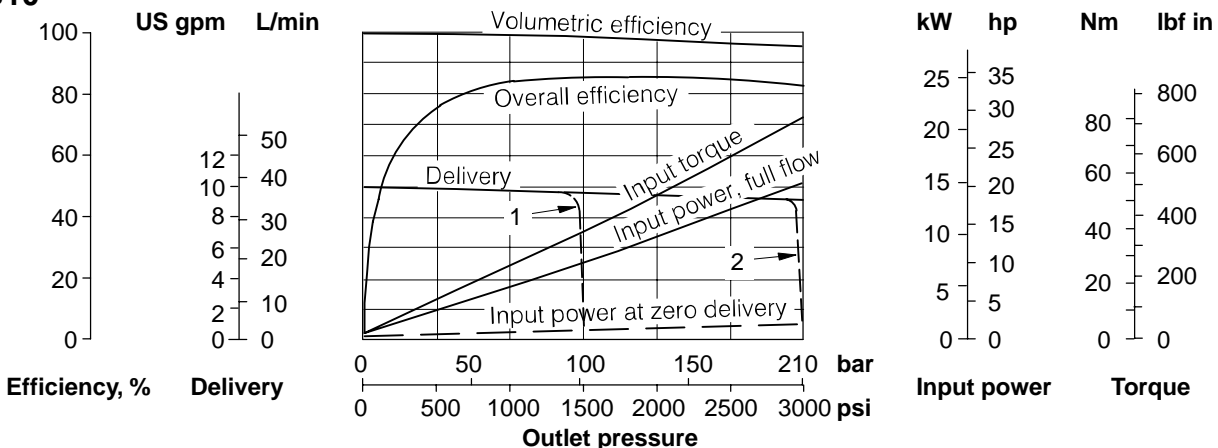

1 = Delivery with compensator setting of 100 bar (1500 psi)  
 2 = Delivery with compensator setting of 200 bar (3000 psi)

# Performance Data at 1800 r/min Drive Speed (cont'd)

With oil at 21cSt (102 SUS) and at 49°C (120°F): Atmospheric inlet  
 For data at drive speed of 1500 r/min, see pages A.7 to A.10

## PVB15

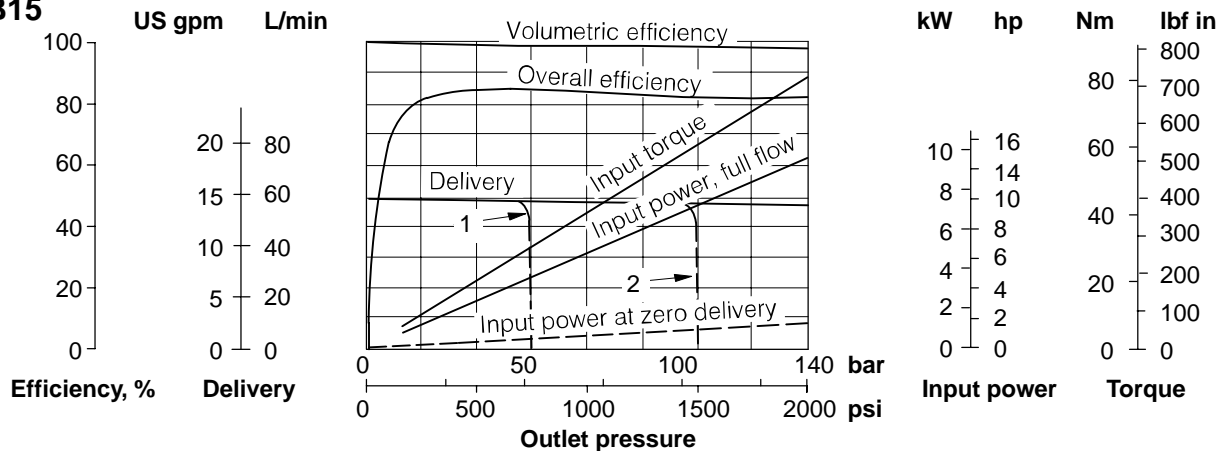

## PVB20

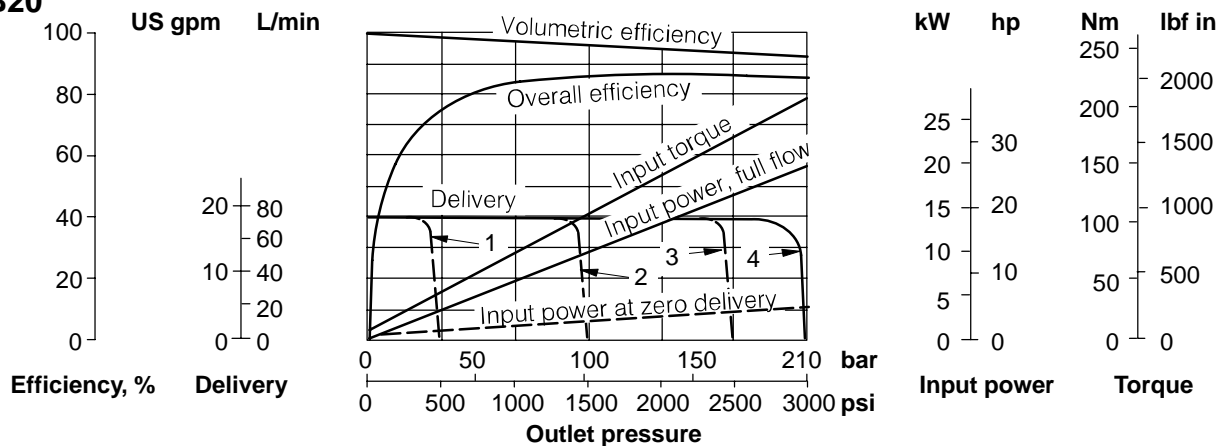

## PVB29

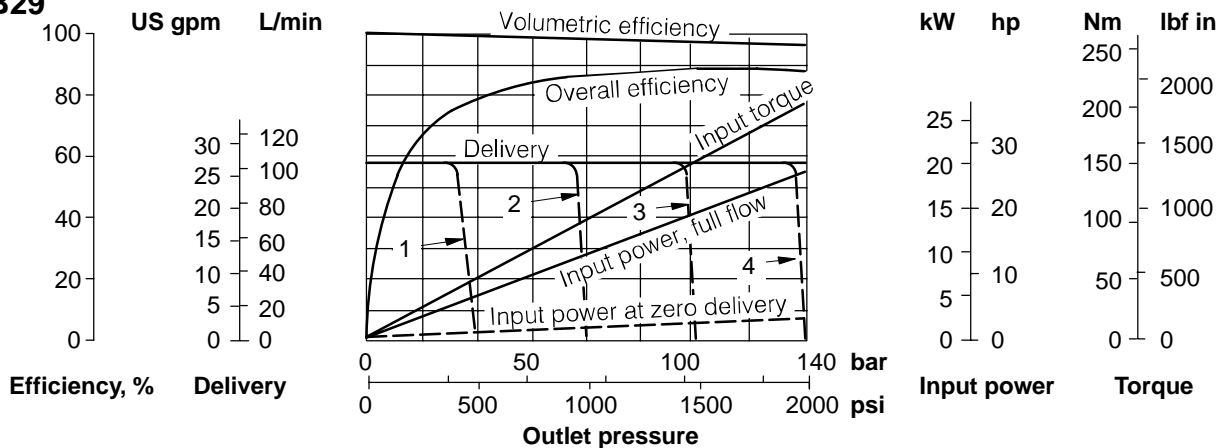

# Performance Data at 1800 r/min Drive Speed (cont'd)

With oil at 21cSt (102 SUS) and at 49°C (120°F): Atmospheric inlet

For data at drive speed of 1500 r/min, see pages A.7 to

A.10

## PVB45

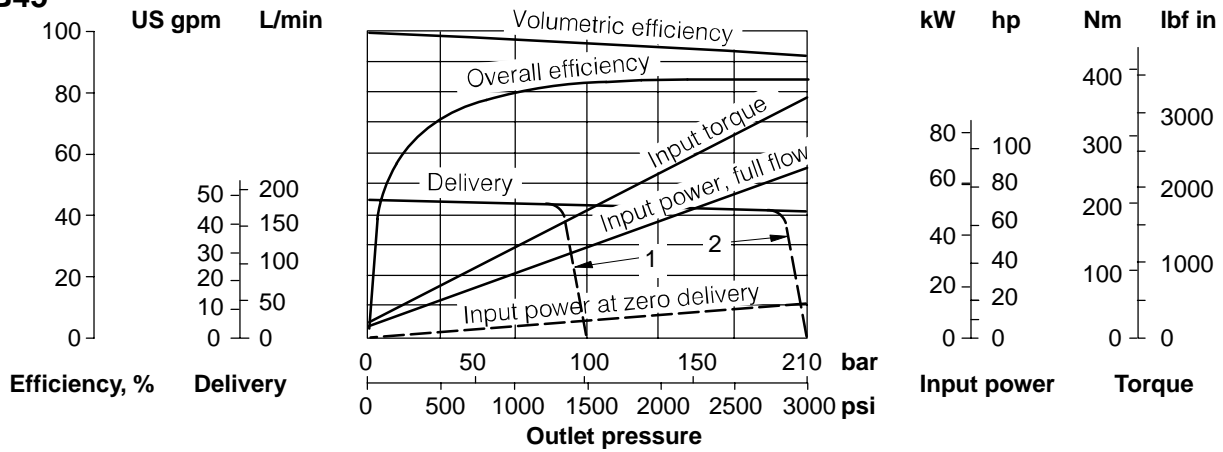

## PVB90

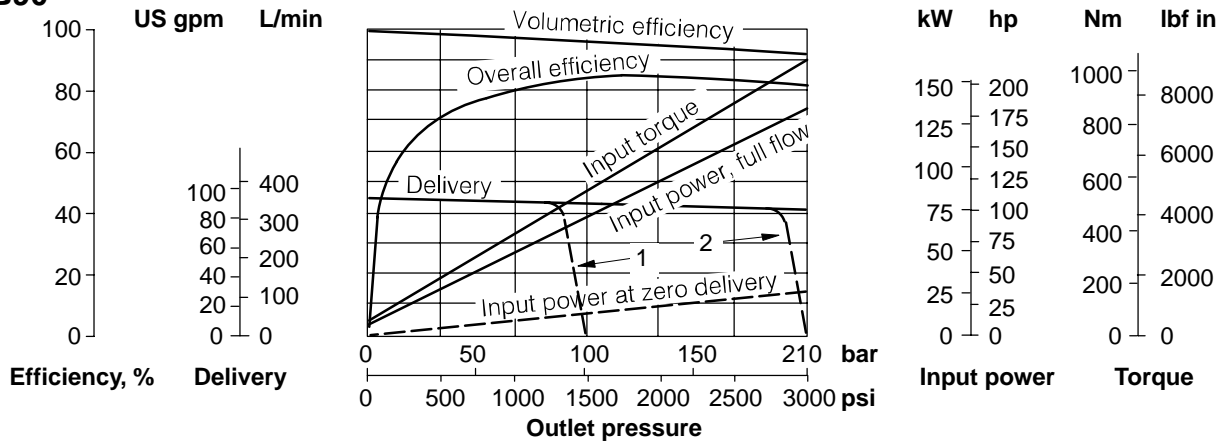

# Control Data for PVB Pumps

Controls available as indicated in "Model Code" section.

## "C" and "CM" Pressure Compensators

Automatically adjusts pump delivery at pre-adjusted pressure to match system demand. Delivery can decrease rapidly from maximum to zero through a pressure gradient typically 4 to 6 bar (60 to 90 psi) with normal circuit volumes.

For pressure adjustment ranges see "Model Code".

### Note:

1. When using PVB6, 15 or 29 pumps with "C" type compensators the user must ensure that the maximum pressure setting never exceeds 140 or 100 bar (2000 or 1500 psi) dependent on the type of fluid being used.



**Caution.** It is possible to mechanically adjust the compensator up to 210 bar (3000 psi).

2. It is recommended that, as for other types of positive pump, a relief valve should be fitted externally as protection against overloads. Where a relatively large amount of fluid is directly subject to compensator pressure, it may be possible to omit the relief valve. Consult your Vickers representative.

## "CC" and "CMC" Pressure Compensators with Adjustable Max. Displacement Stop

The pressure compensator section performs as described above. The adjustable stop allows the maximum pump delivery to be adjusted between 25 to 100%. To assist priming, adjust the stop setting to provide at least 40% of the maximum displacement.

## "CG" Pressure Compensator, Remotely Controlled

Same as the "C" compensator, but arranged for remote pressure adjustment by suitable pilot controls. One or more pilot relief valves (e.g. C-175-\*) and/or pilot directional valves, in series or in parallel, can provide many varied remote pilot systems.

Your Vickers representative will be pleased to advise on optimum arrangements for individual applications.

## "CV" Load Sensing Comensator, Remotely Controlled

Automatically matches pump delivery to system demand at a pressure approximately 17 bar (250 psi) above load pressure. This pressure difference can be created by:

- a variable flow restrictor (non-compensated flow control) or the spool opening of a directional control valve.

Both forms can be used with fixed and variable speed pump drives. In the latter case a fixed restrictor can provide pre-set, near-constant pump flow independent of drive speed, provided that the speed exceeds that which gives the required flow at full displacement. An external pressure limiter must be added to prevent overloading the pump; see "Functional Symbols" page A.3.

The matching of pump pressure and delivery to system demands provides power matching and conservation by minimizing system power wastage.

## "H" Handwheel Control

Provides manual variation or selection of pump delivery. The control can be operated on both sides of center permitting bi-directional flow characteristics.

Approximate change of displacement per one turn of handwheel is:

PVB5	.....	2,6 cm <sup>3</sup> (0.16 in <sup>3</sup> )
PVB6	.....	3,4 cm <sup>3</sup> (0.21 in <sup>3</sup> )
PVB10	.....	5,2 cm <sup>3</sup> (0.32 in <sup>3</sup> )
PVB15	.....	8,2 cm <sup>3</sup> (0.5 in <sup>3</sup> )

## "M" Lever Control

Provides mechanical or manual variation of pump delivery in approximate proportion to the angular movement from the center position. This control may be operated on both sides of center permitting bi-directional flow characteristics. The pintle-mounted lever control must be secured by suitable linkage to maintain desired settings; both extremes of pintle travel are limited by internal stops to approx. 17.5° from center.

Control torques (approx. at 1500 r/min).	
PVB5	..... 3,8 Nm @ 210 bar (33 lbf in at 3000 psi)
PVB6	..... 2,7 Nm @ 138 bar (24 lbf in at 2000 psi)
PVB10 and PVB15	.. 7,5 Nm @ 70 bar (66 lbf in at 1000 psi)

**Note:** Torque varies with pressure and speed.

## "GE1" Minimum Displacement Control

Option for C(M)(C) and CG(C) compensators to limit the minimum displacement, in the fully compensated mode, to nominally 10% of full displacement.

## Hydraulic Fluids

All pumps can be used with anti-wear hydraulic oils, water glycols and water-in-oil (invert) emulsions. It is possible to use these pumps with high water base fluids (e.g. 5%/95% oil-in-water emulsion) at pressures up to 70 bar (1000 psi). However, first consult your Vickers representative.

The extreme operating viscosity range is from 220 to 13 cSt (1020 to 70 SUS) for all pumps (except where 5%/95% emulsions are used). The recommended running range is 54 to 13 cSt. (245 to 70 SUS)

The viscosity of 5%/95% emulsions is near-constant at about 1 or 2 cSt (<35 SUS).

**Temperature Limits**

Minimum ambient . . . . . -20°C (-4°F)  
 Maximum ambient. . . +70°C (+158°F)

*\* To obtain maximum service life from both fluid and hydraulic system, 65° C (150° F) normally is the maximum temperature except for water-containing fluids. Whatever the actual temperature range, ensure that viscosities stay within the limits specified in "Hydraulic Fluids" section.*

**- Drive Methods**

Direct co-axial drive through a suitable flexible coupling is preferred. If an indirect drive is to be used, first consult your Vickers representative.

**Fluid Temperatures**

	Mineral oil	Water-containing
Minimum	-20°C (-4°F)	+10°C (+50°F)
Maximum*	+80°C (+176°F)	+54°C (+129°F)

**Filtration Requirements**

20/18/14 or ISO 18/14..

**Drive Requirements:**

**- Direction of Rotation**

Clockwise or anti-clockwise (viewed at shaft end) to order; see also "Model Code", and "Installation Dimensions" sections.

**Noise Levels**

\* Typical values equivalent to NFPA

Speed r/min	Pressure bar (psi)	Stroke	Noise level – dB(A)*						
			PVB5	PVB6	PVB10	PVB15	PVB20	PVB29	
1000	35 (500)	Full flow	51	52	54	58	–	–	
		Cutoff	51	51	44	47	–	–	
	70 (1000)	Full flow	54	55	56	60	–	–	
		Cutoff	52	54	49	54	–	–	
	140 (2000)	Full flow	56	57	60	62	–	–	
		Cutoff	58	56	55	59	–	–	
	210 (3000)	Full flow	60	–	61	–	–	–	
		Cutoff	59	–	59	–	–	–	
	1200	35 (500)	Full flow	50	51	55	60	–	–
			Cutoff	52	51	48	51	–	–
70 (1000)		Full flow	54	55	57	61	74	70	
		Cutoff	56	57	51	54	–	–	
140 (2000)		Full flow	59	59	60	63	74	73	
		Cutoff	59	60	54	58	69	76	
210 (3000)		Full flow	60	–	62	–	78	–	
		Cutoff	61	–	56	–	–	–	
1500		35 (500)	Full flow	54	54	58	63	–	–
			Cutoff	52	52	51	52	–	–
	70 (1000)	Full flow	58	58	60	64	–	–	
		Cutoff	57	57	55	55	–	–	
	140 (2000)	Full flow	61	62	62	66	–	–	
		Cutoff	62	59	62	59	–	–	
	210 (3000)	Full flow	64	–	65	–	–	–	
		Cutoff	62	–	63	–	–	–	
	1800	35 (500)	Full flow	57	58	61	64	–	–
			Cutoff	55	57	55	56	–	–
70 (1000)		Full flow	60	61	63	67	76	77	
		Cutoff	59	58	59	60	–	–	
140 (2000)		Full flow	63	66	65	69	81	81	
		Cutoff	62	63	62	64	75	81	
210 (3000)		Full flow	64	–	67	–	81	–	
		Cutoff	64	–	65	–	–	–	



# PFB5 SAE Flange Mounting

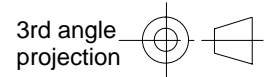

## Installation Dimensions in mm (inches)

Optional foot bracket, shown in dashed outline; kit FB-A-10 comprises foot bracket and two pump fixing bolts. Order separately, if required.

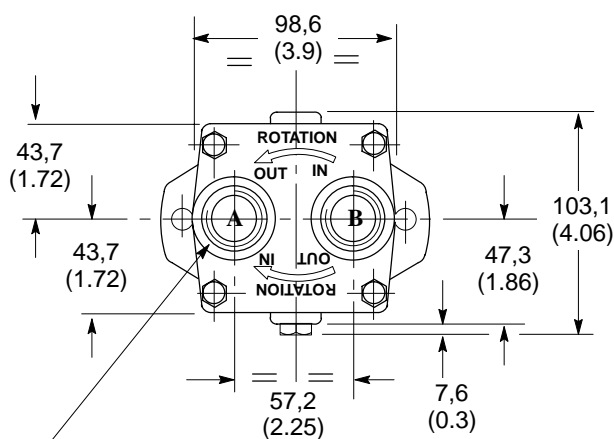
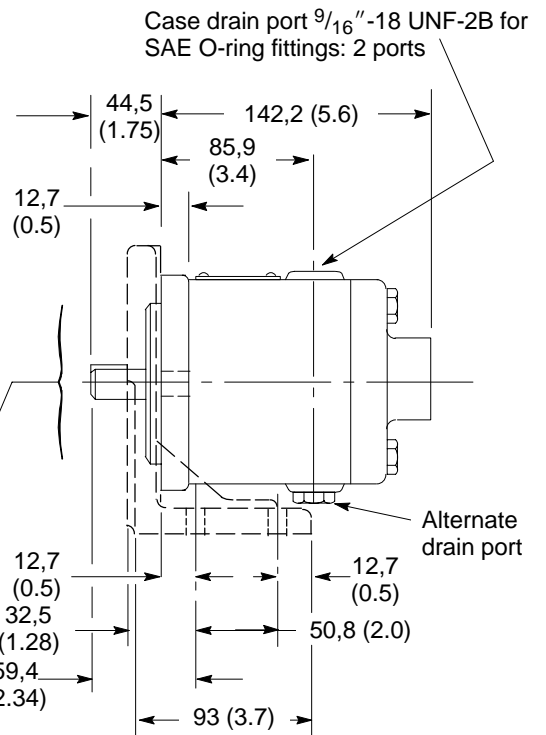
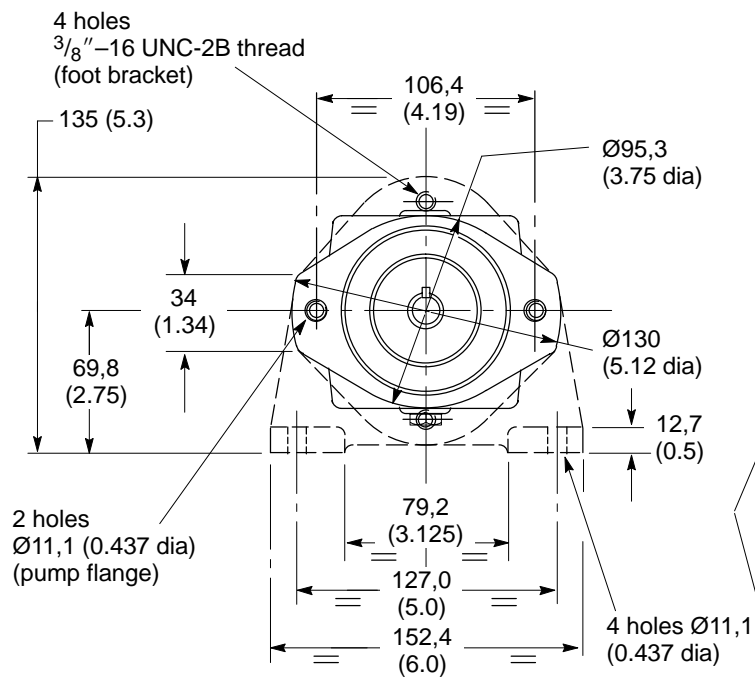

Inlet/outlet ports:  $\frac{11}{16}$ "-12 UNF-2B thread for SAE O-ring fittings.

**View on rear end of pump**

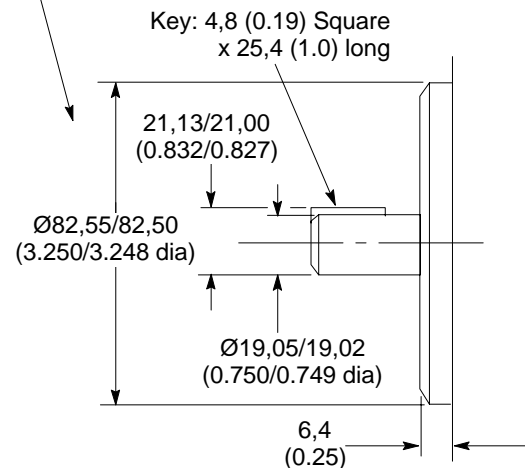

**Detail of shaft, key and locating diameter**

# PFB10 SAE Flange Mounting

Installation Dimensions in mm (inches)

Optional foot bracket, shown in dashed outline; kit FB-B-10 comprises foot bracket and two pump fixing bolts. Order separately, if required.

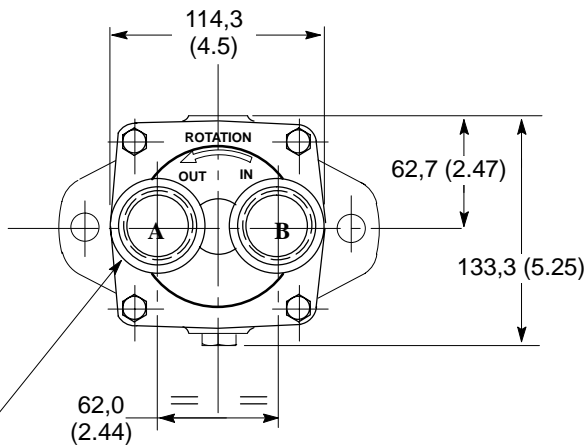
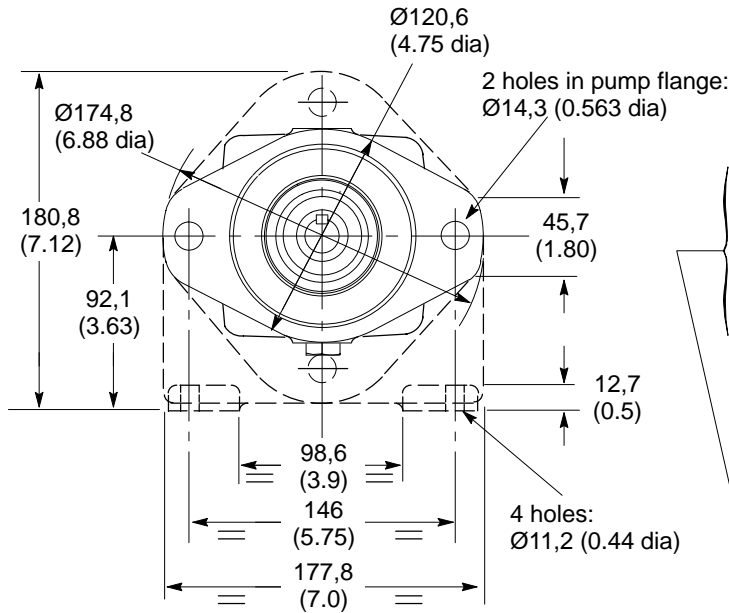

Inlet/outlet ports:  
1<sup>5</sup>/<sub>8</sub>"-12 UNF-2B thread for SAE O-ring fittings.

View on rear end of pump

Case drain port 3/4"-16 UNF-2B for SAE O-ring fittings: 2 ports

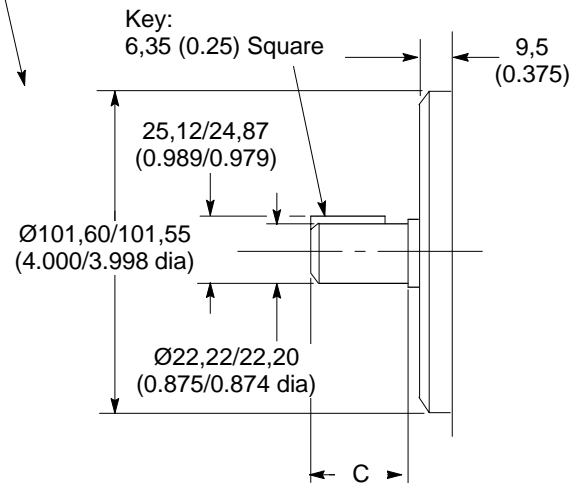
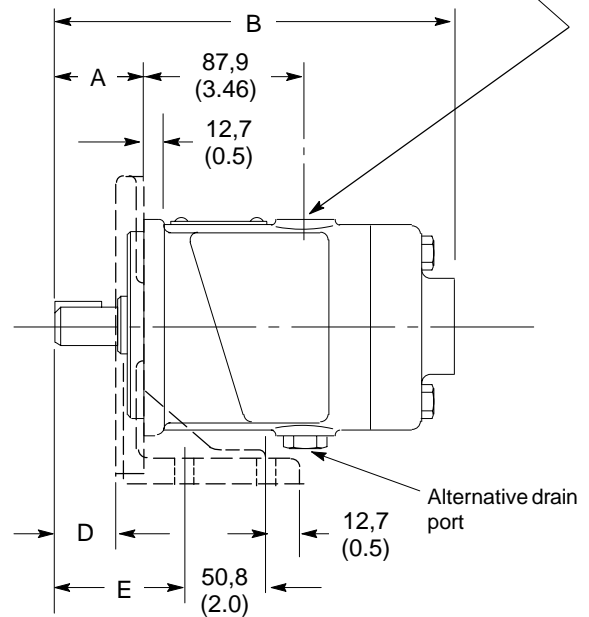

Detail of shaft, key and locating diameter

Pump type	A	B	C	D*	E*
PFB10-*-30	44,4 (1.75)	213,9 (8.42)	33,3 (1.31)	26,9 (1.06)	59,4 (2.34)
PFB10-*Y-30	58,7 (2.31)	228,1 (8.98)	47,6 (1.87)	41,1 (1.62)	73,7 (2.9)

\*Omit for foot bracket models)

# PFB20 SAE Flange Mounting

Installation Dimensions in mm (inches)

Optional foot bracket, shown in dashed outline; kit FB-B-10 comprises foot bracket and two pump fixing bolts. Order separately, if required.

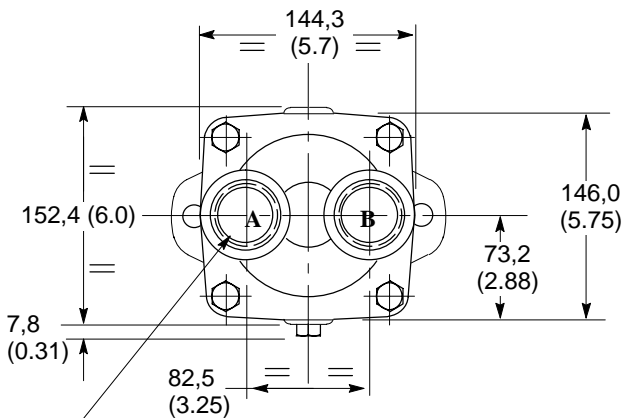
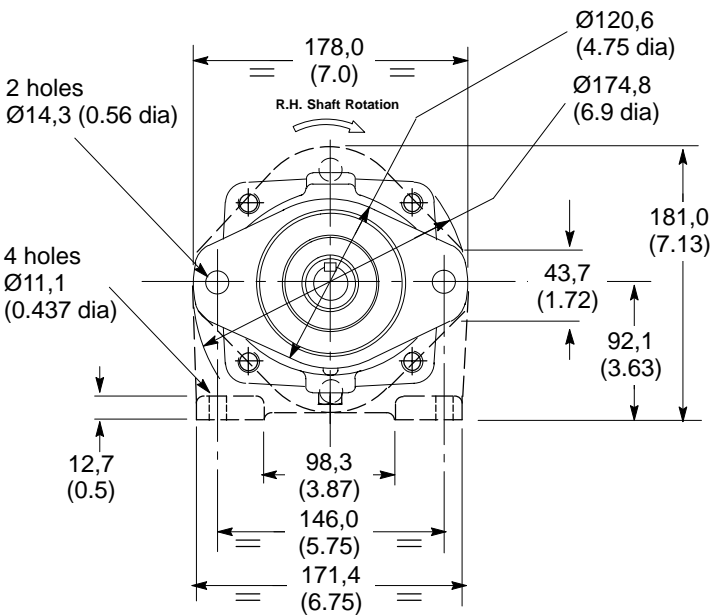

View on rear end of pump

Shaft rotation	Inlet port	Outlet port
RH	B	A
LH	A	B

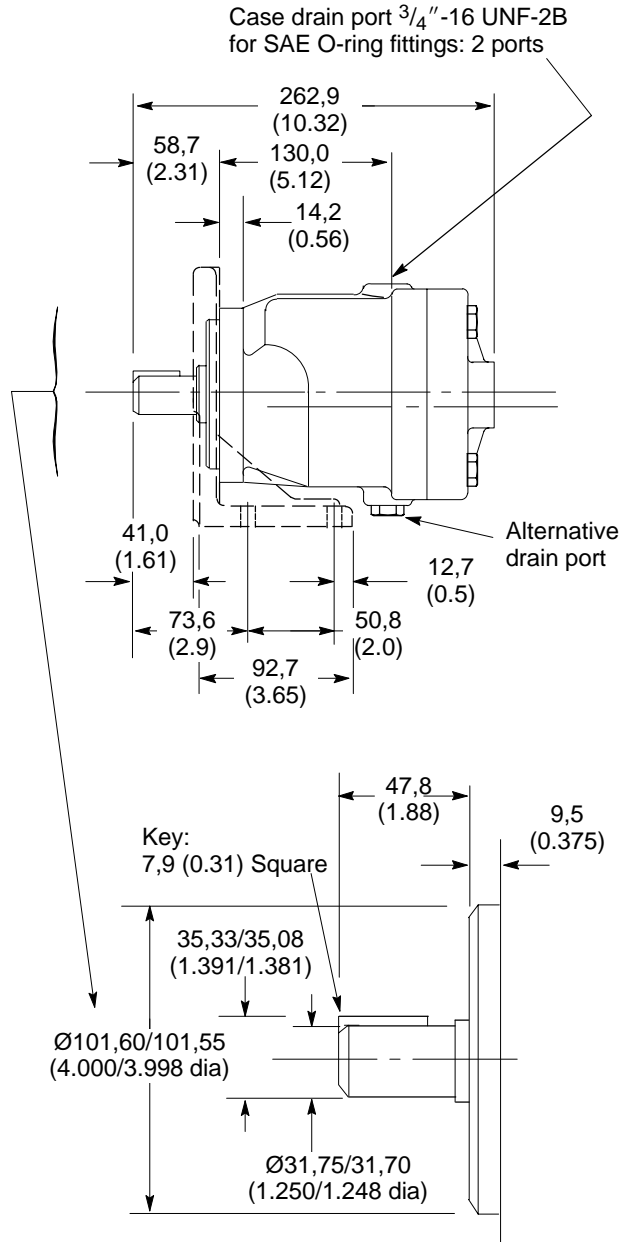

Detail of shaft, key and locating diameter

# PVB5/6 SAE Flange Mounting: Pressure Compensator Control - "C" and "CM"

Installation Dimensions in mm (inches)

See also "Control Data" section, page A.15.

Optional foot bracket, shown in dashed outline; kit FB-A-10 comprises foot bracket and two pump fixing bolts. Order separately, if required.

Case drain port  $\frac{9}{16}$ "-18 UNF-2B for SAE O-ring fittings: 2 ports

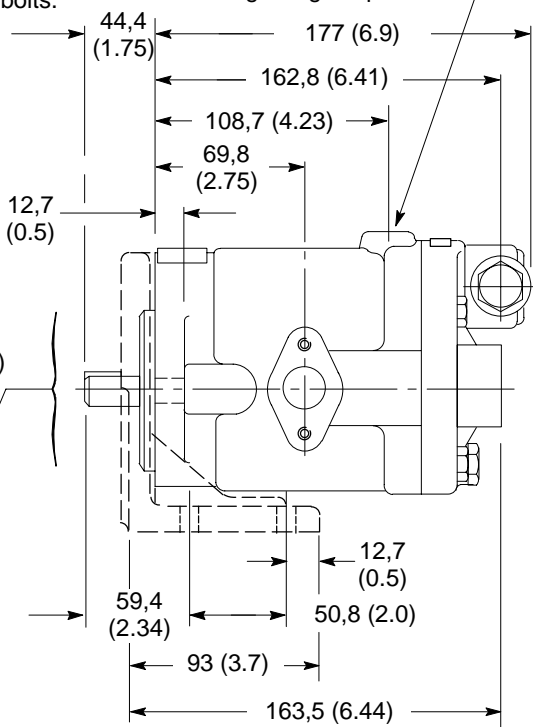
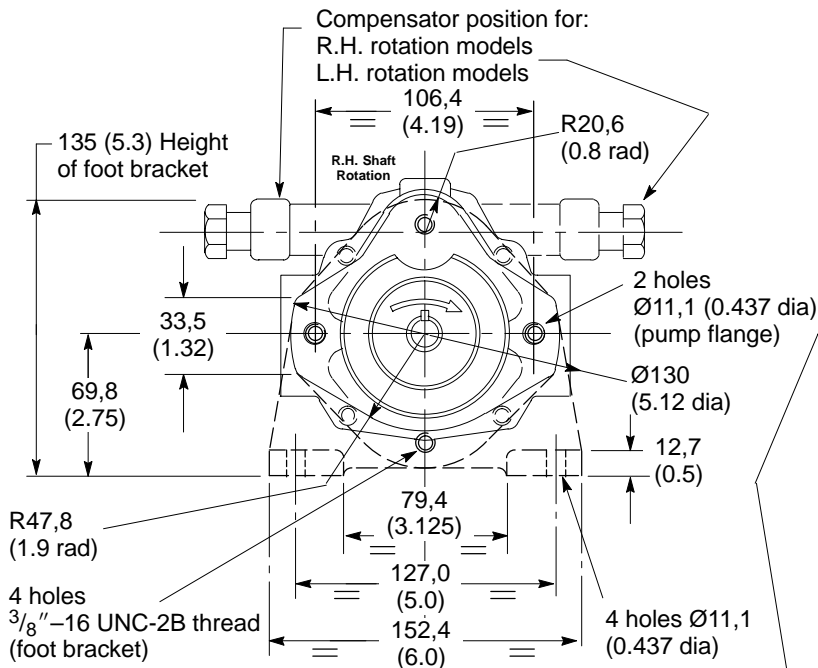

Caution: While pump is operating do not back compensator adjustment screw out beyond dimension shown.

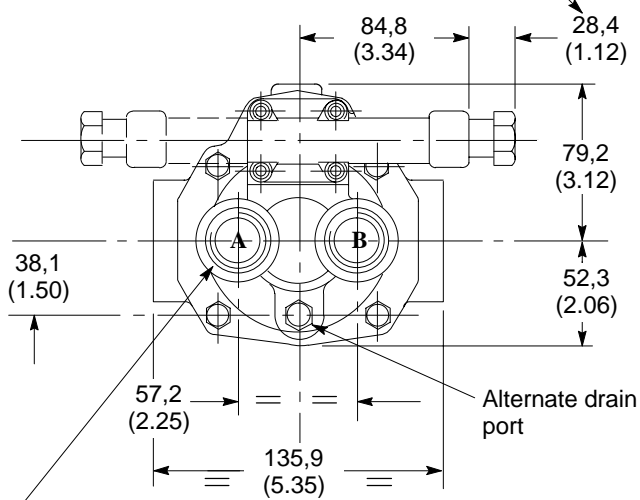

Inlet/outlet ports (see table):  
 $\frac{11}{16}$ "-12 UNF-2B thread for SAE O-ring fittings.

View on rear end of pump

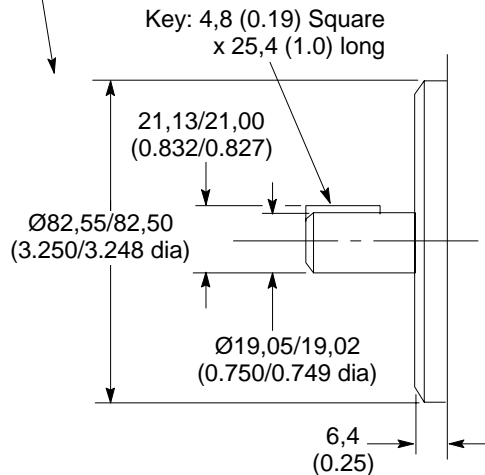

Detail of shaft, key and locating diameter

Shaft rotation	Inlet port	Outlet port
RH	A	B
LH	B	A

# PVB5/6 Thru-Shaft Models (with Side Ports)

Installation Dimensions in mm (inches)

Maximum output torque is 40 Nm (354 lbf in), less unput torque at system pressure, see performance curves:  
 At 1500 r/min drive speed, page A.8.  
 At 1800 r/min drive speed, page A.12.

For other dimensions and installation data see page A.20.

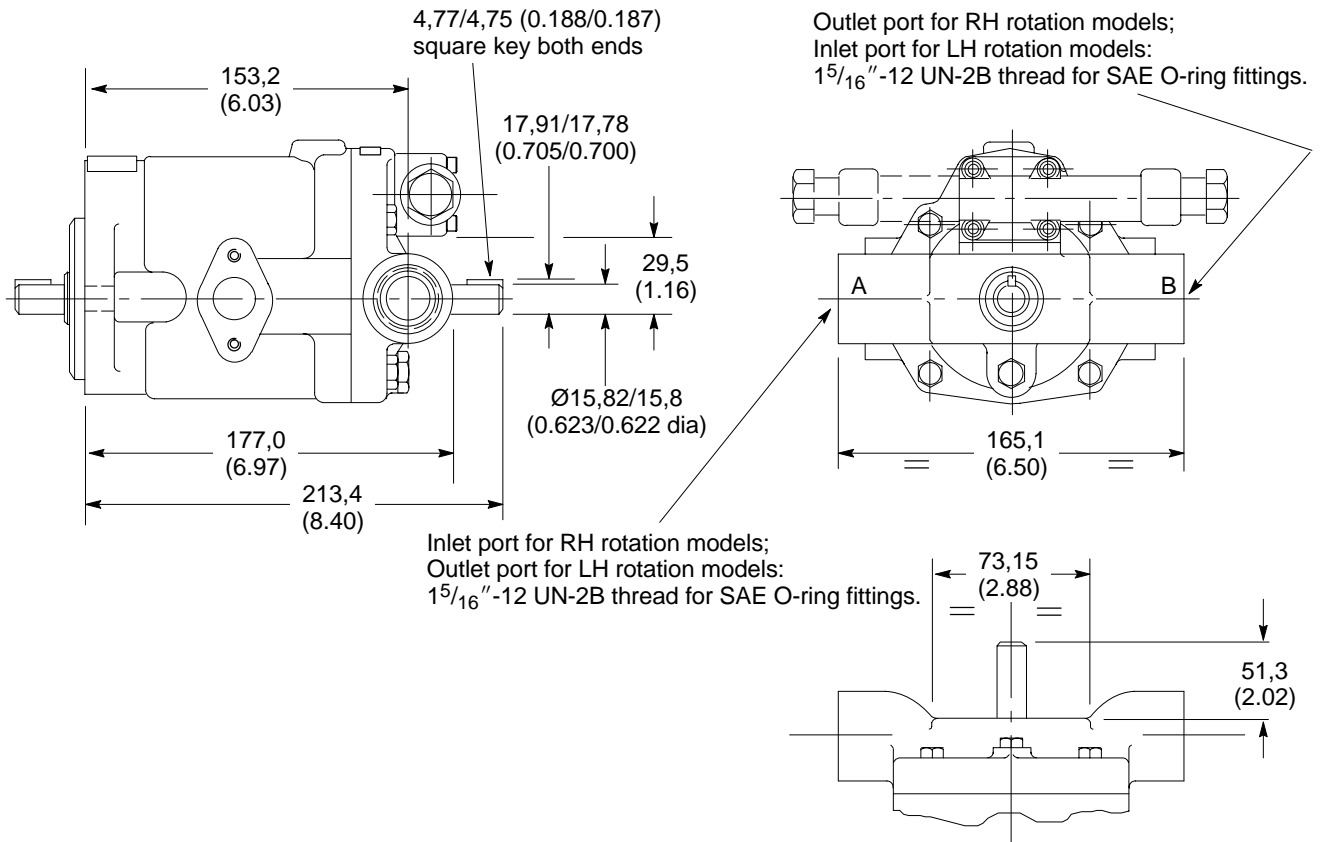

# PVB10/15 SAE Flange Mounting Pressure Compensator Control - "C" and "CM"

Installation Dimensions in mm (inches)  
See also "Control Data" section, page A.15.

Optional foot bracket, shown in dashed outline; kit FB-B-10 comprises foot bracket and two pump fixing bolts.  
Order separately, if required.

Case drain port .750-16 UNF-2B for SAE O-ring fittings: 2 ports

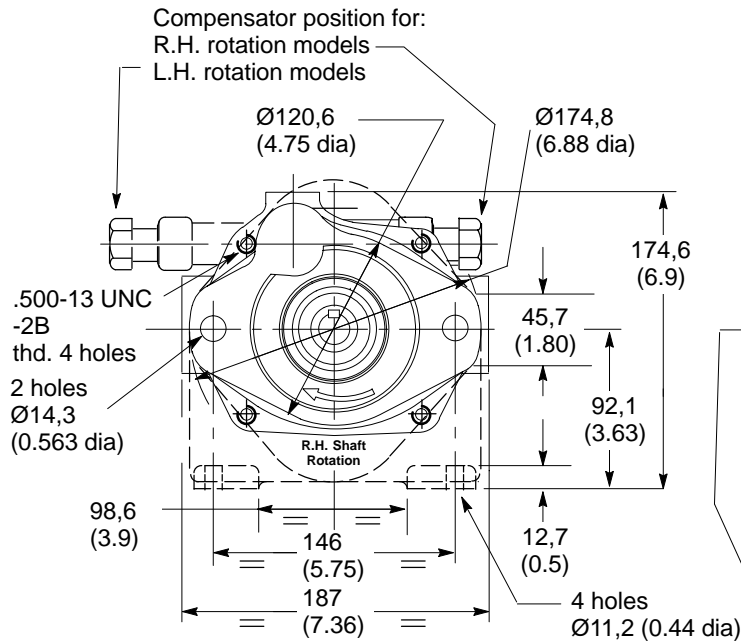

Caution: While pump is operating do not back compensator adjustment screw out beyond dimension shown.

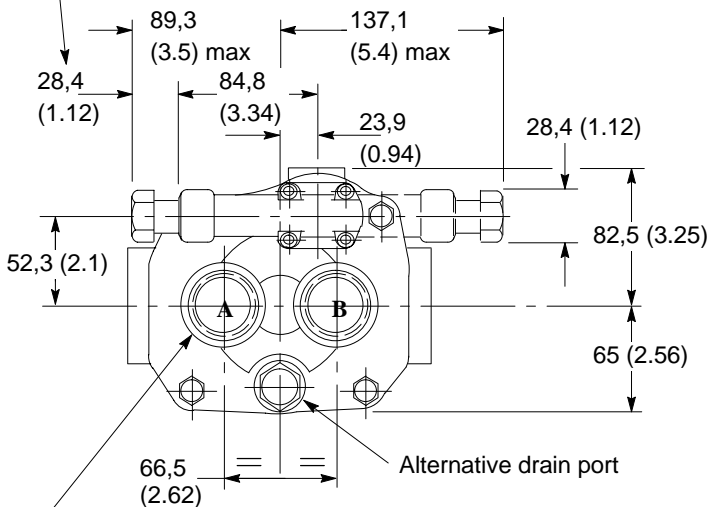

Inlet/outlet ports (see table):  
1.625-12 UN-2B thread for SAE O-ring fittings.

View on rear end of pump

Shaft rotation	Inlet port	Outlet port
RH	A	B
LH	B	A

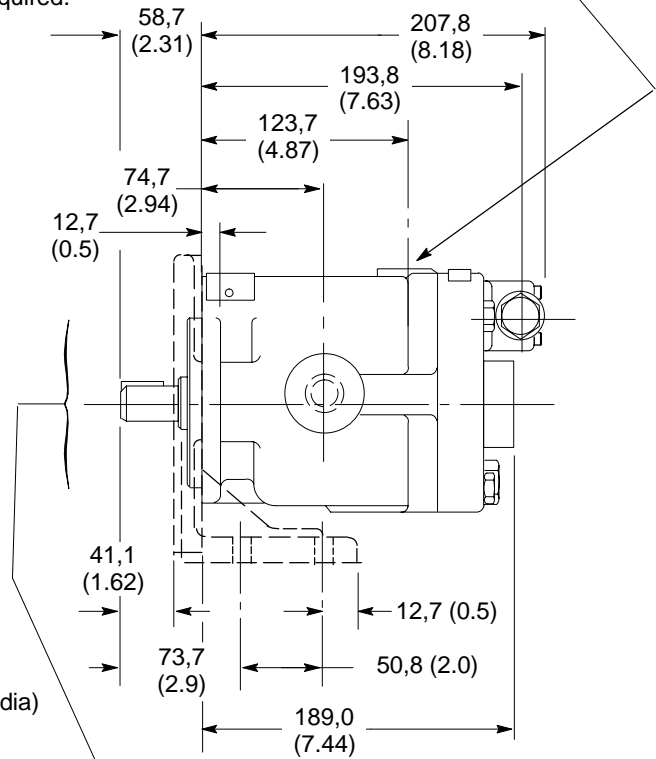

Key: 6,4 (0.25) Square x 22,3 (0.88) long

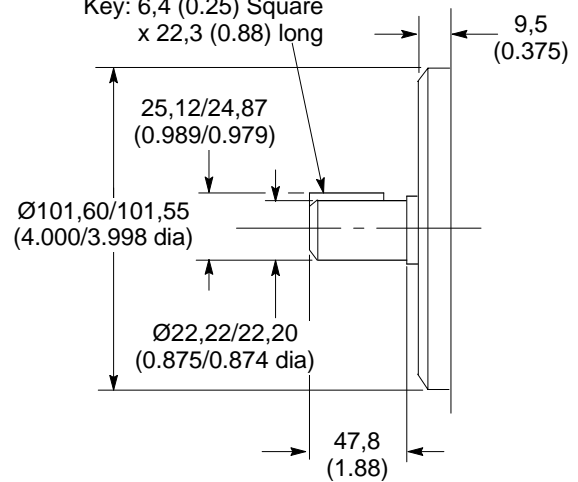

Detail of shaft, key and locating diameter

# PVB10/15 Thru-Shaft Models (with Side Ports)

Maximum output torque is 83 Nm (735 lbf in), less unput torque at system pressure, see performance curves:  
 At 1500 r/min drive speed, pages A.8 & A.9.  
 At 1800 r/min drive speed, page A.12 & A.13.

For other dimensions and installation data see page A.22.

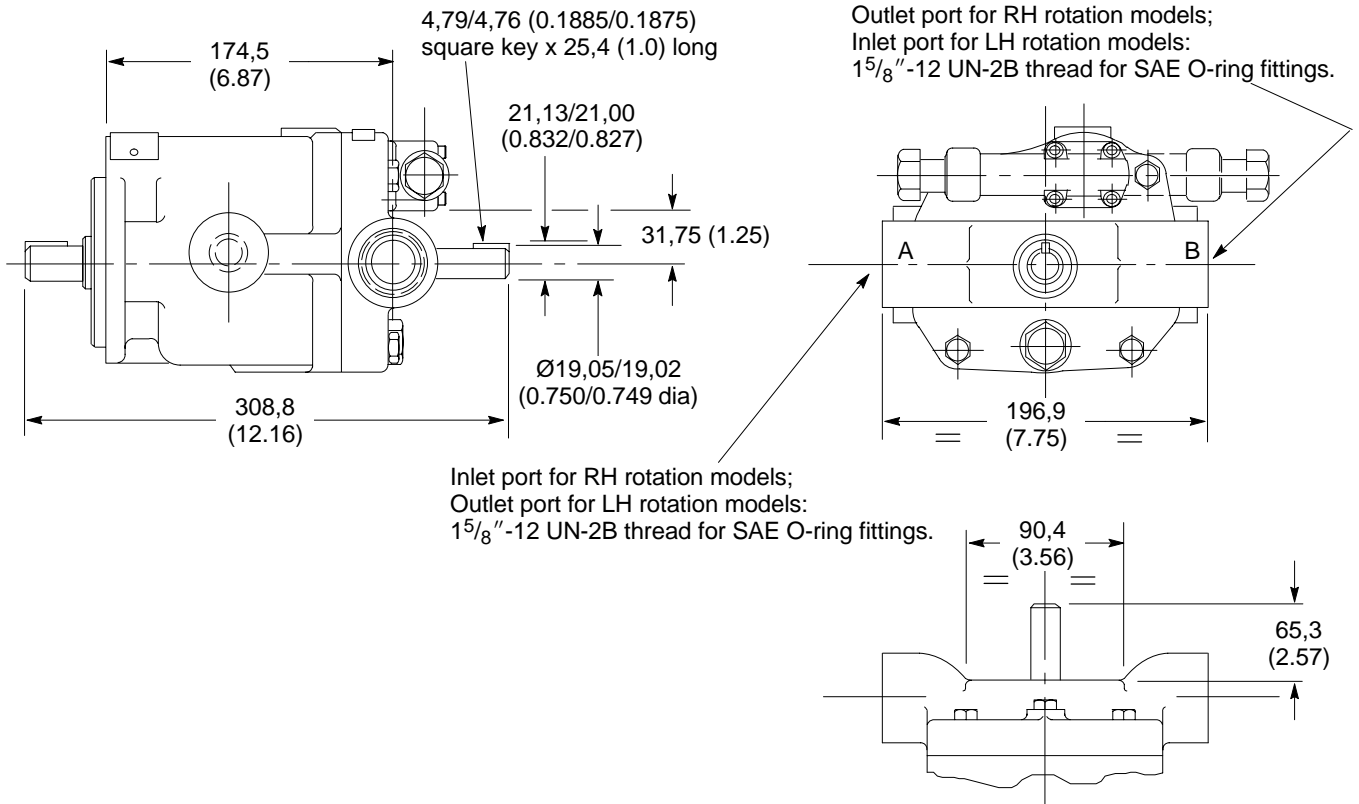

# PVB5/6 and PVB10/15 Manual/Mechanical Controls

## Lever Control - "M" and No Control - "V"

Units with this control may be operated on both sides of center permitting bi-directional fluid flow characteristics.

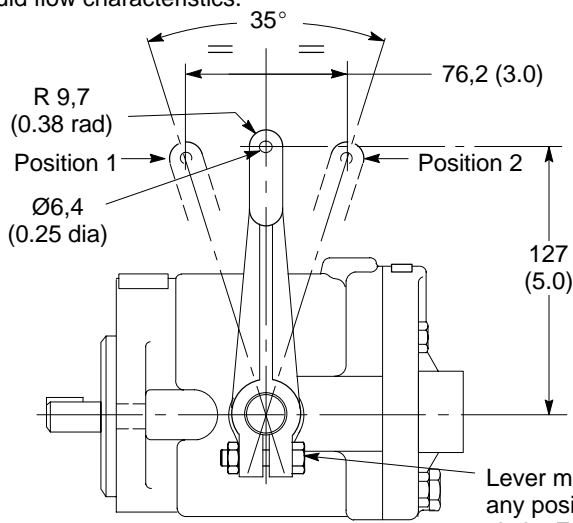

Lever may be set at any position in 360° circle. Ensure clamp bolt is fully tightened.

Shaft rotation	Lever position	Outlet port
RH	1	A
	2	B
LH	1	B
	2	A

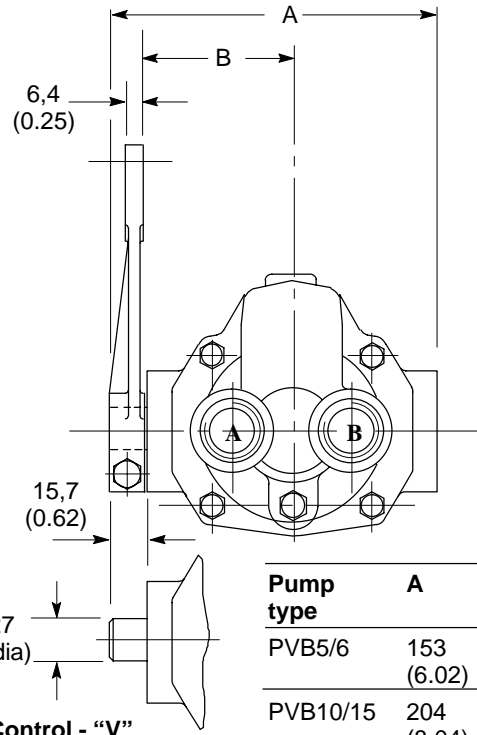

Pump type	A	B
PVB5/6	153 (6.02)	68,9 (2.7)
PVB10/15	204 (8.04)	99,9 (3.93)

No Control - "V"

## Handwheel Control - "H"

Units with this control may be operated on both sides of center permitting bi-directional fluid flow characteristics.

Max. flow adjustment.  
Adjust and lock  
to limit max. flow.

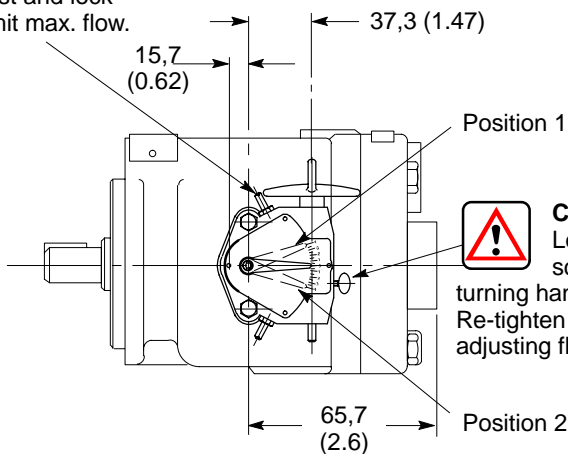

**Caution!**  
Loosen lock screw before turning handle. Re-tighten after adjusting flow.

Shaft rotation	Pointer position	Handwheel rotation from zero	Outlet port
RH	1	Clockwise	A
	2	Counter-clockwise	B
LH	1	Clockwise	B
	2	Counter-clockwise	A

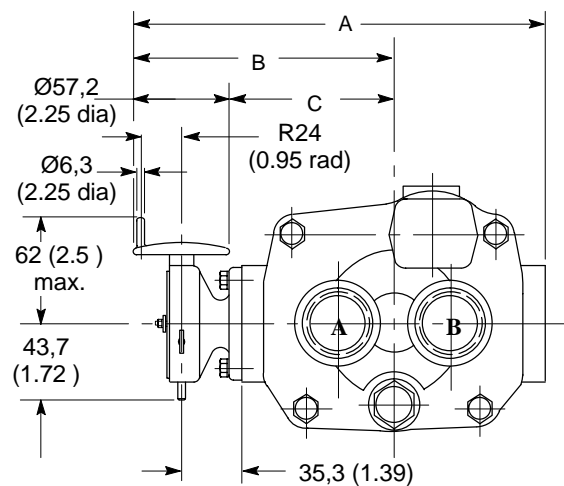

Pump type	A	B	C
PVB5/6	200 (7.87)	129 (5.08)	70,6 (2.78)
PVB10/15	250 (9.84)	140 (5.51)	93,5 (3.68)



# PVB20/29 SAE Flange Mounting Pressure Compensator Control - "C" and "CM"

Installation Dimensions in mm (inches)  
See also "Control Data" section, page A.15.

Optional foot bracket, shown in dashed outline; kit FB-C-10 comprises foot bracket and two pump fixing bolts. Order separately, if required.

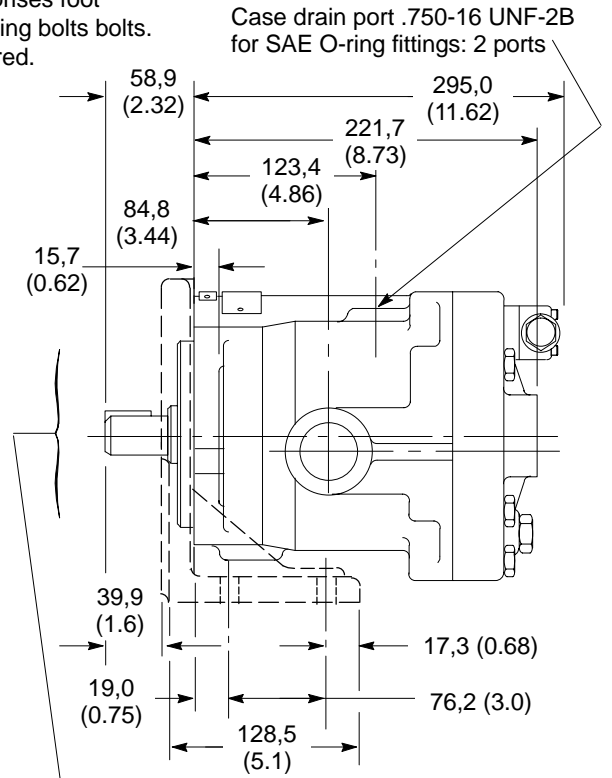
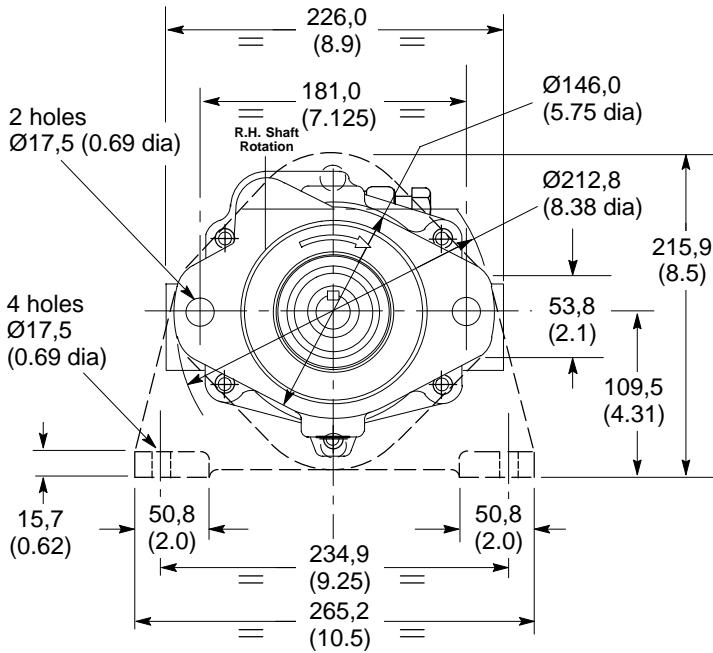

Caution: While pump is operating do not back compensator adjustment screw out beyond dimension shown.

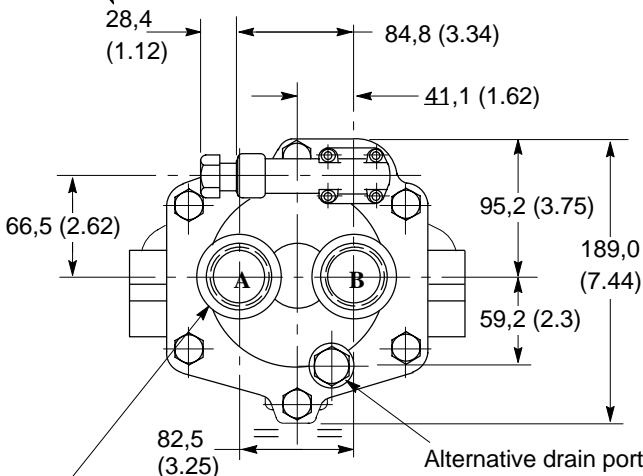

Inlet/outlet ports (see table):  
1.625-12 UNF-2B thread for SAE O-ring fittings.

View on rear end of pump

Shaft rotation	Inlet port	Outlet port
RH	A	B
LH	B	A

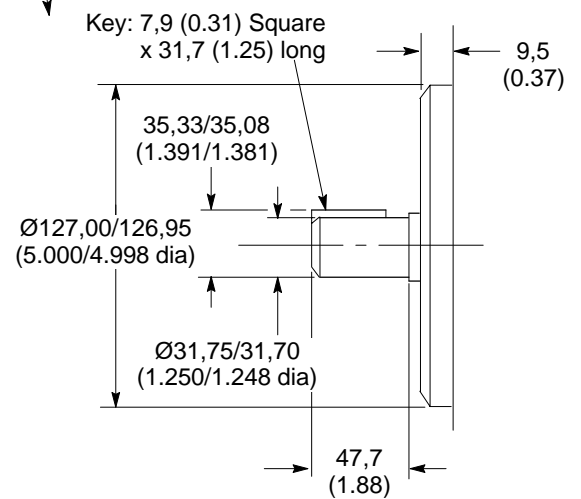

Detail of shaft, key and locating diameter

# PVB20/29 Thru-Shaft Models (with Side Ports)

Maximum output torque is 159 Nm (1408 lbf in), less unput torque at system pressure, see performance curves:

At 1500 r/min drive speed, page A.9

At 1800 r/min drive speed, page A.13

For other dimensions and installation data see page A.25.

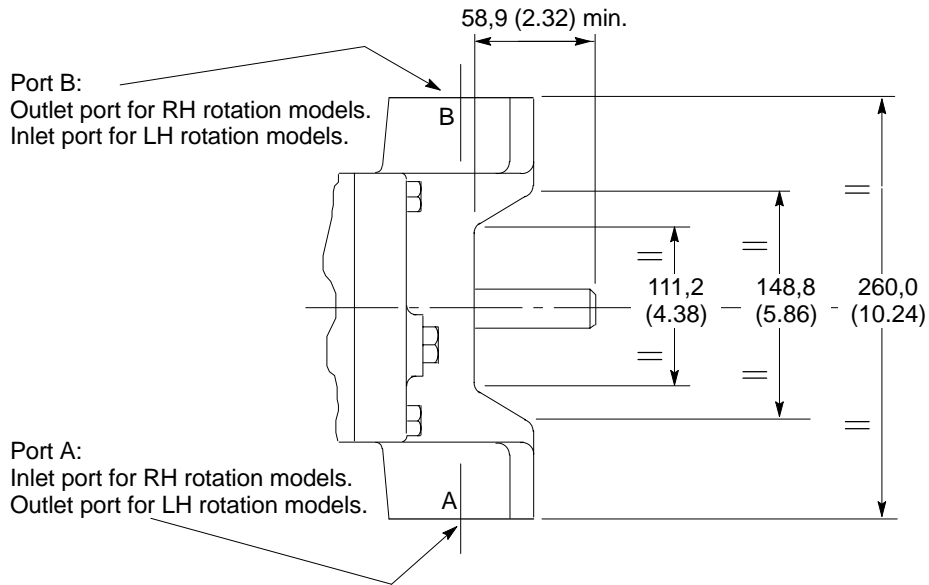
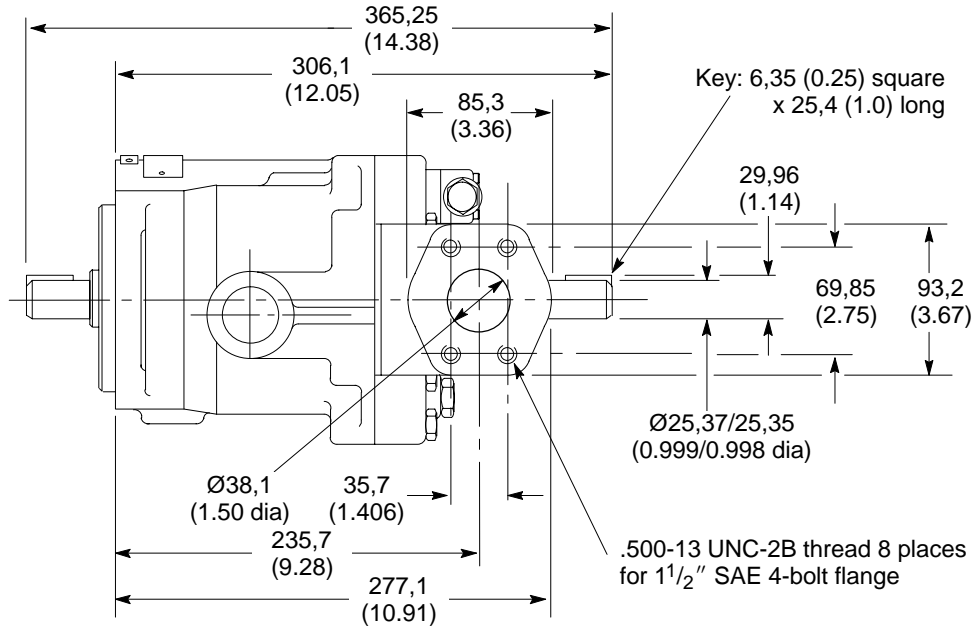

# PVB45 Flange-Mounted Model

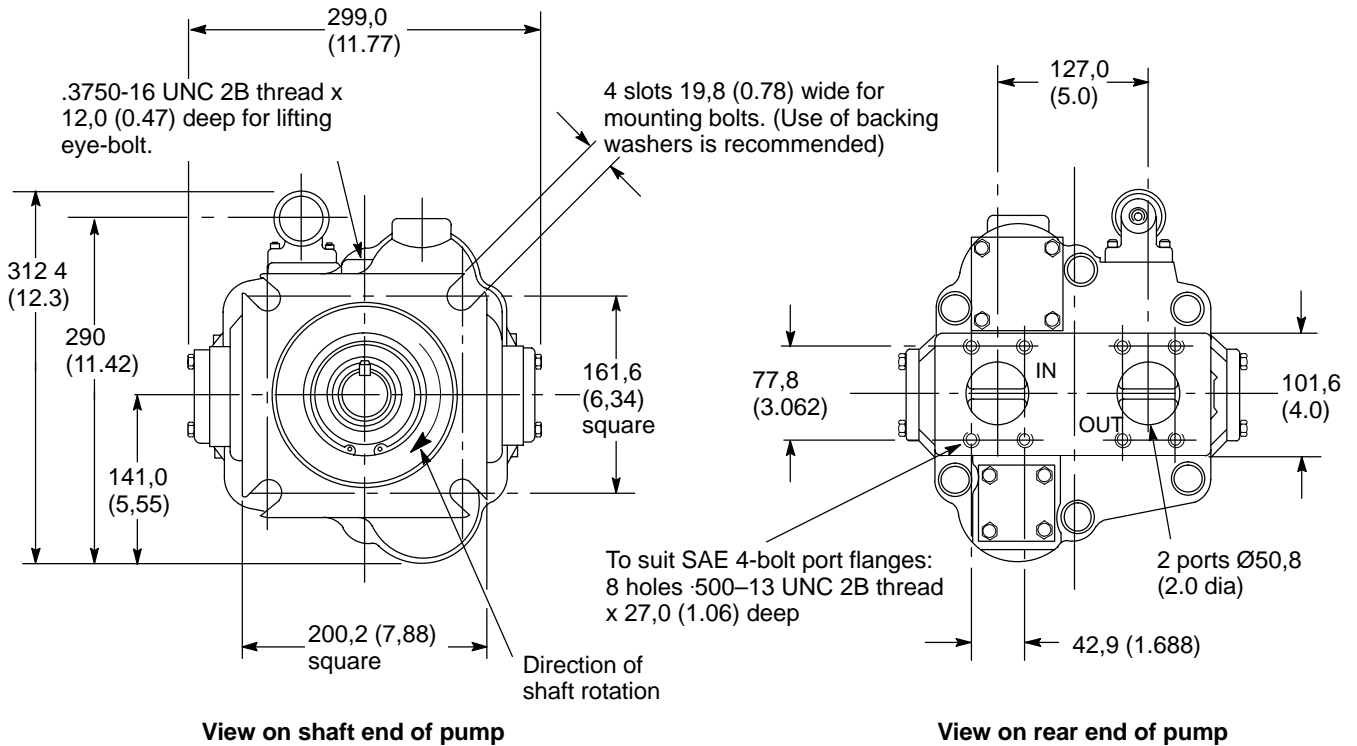
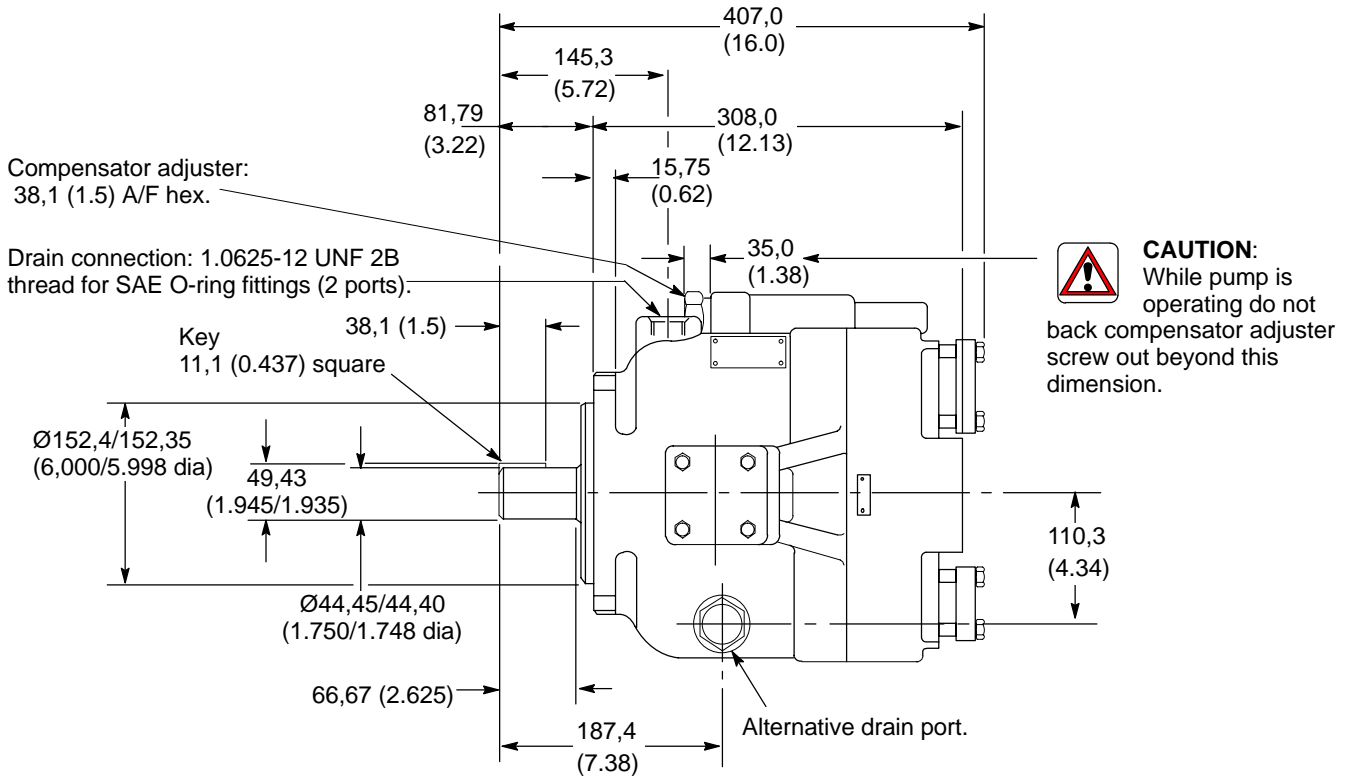

# PVB45 Foot-Mounted Model

For other dimensions and installation data see page A.27 .

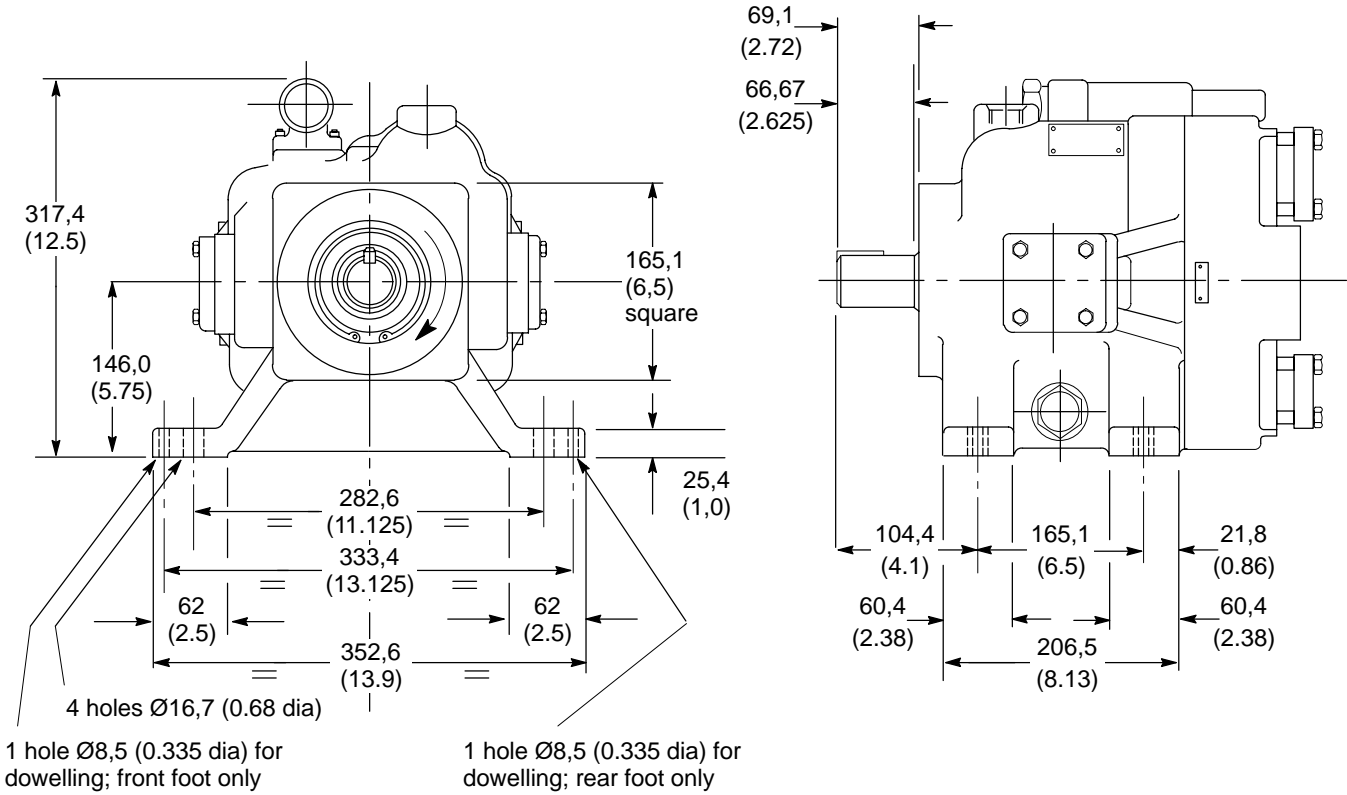

# PVB90

Foot mounting option (designated by Model Code ③ = "F") is shown in dotted outline. An alternative base mounting facility is provided by four tapped holes in the bottom face of the pump - see page A.30.

Compensator adjuster:  
38,1 (1.5) A/F hex.

Drain connection:  
1.3125-12 UN 2B thread for SAE  
O-ring fittings (2 ports).

Key 11,1 (0.437) square  
x 44,5 (1.75) long

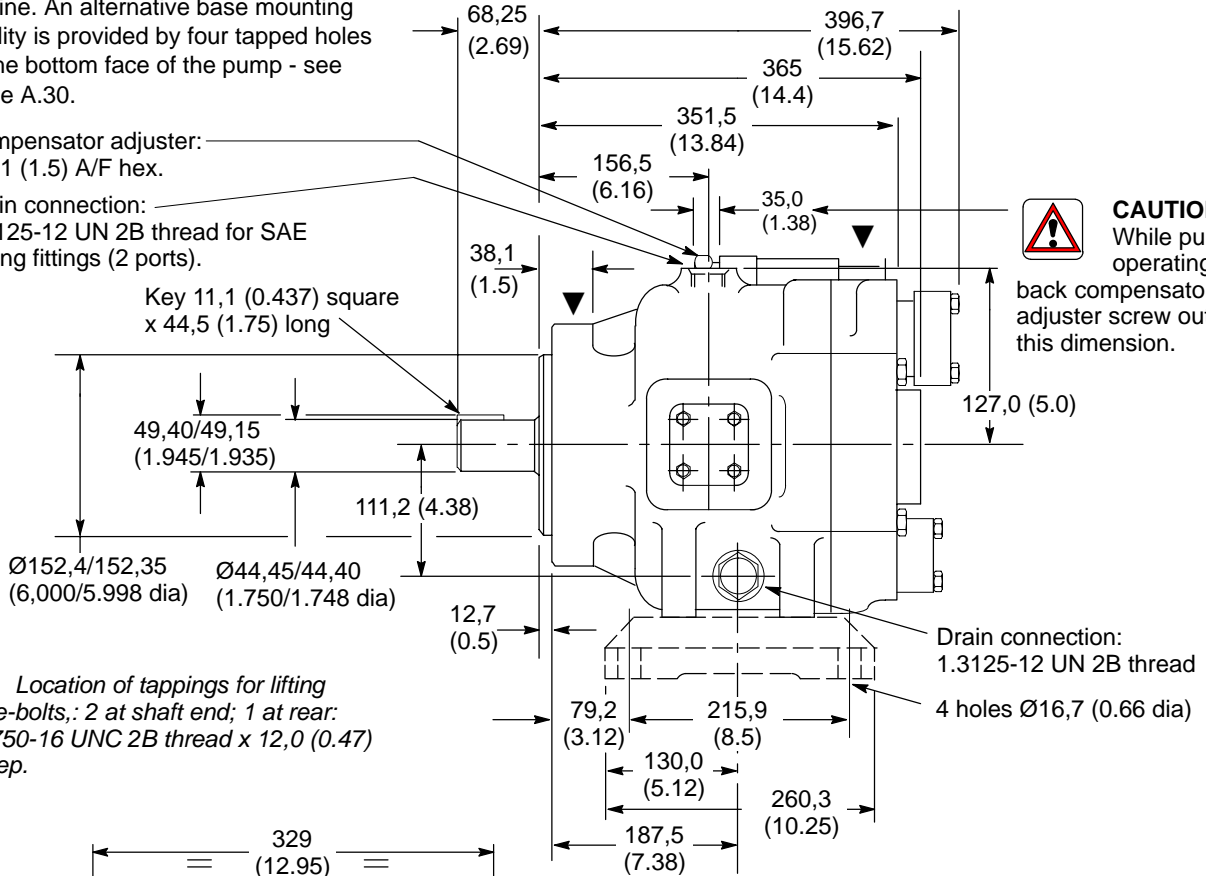

**CAUTION:**  
While pump is operating do not back compensator adjuster screw out beyond this dimension.

▼ Location of tapings for lifting eye-bolts; 2 at shaft end; 1 at rear:  
.3750-16 UNC 2B thread x 12,0 (0.47) deep.

Drain connection:  
1.3125-12 UN 2B thread  
4 holes Ø16,7 (0.66 dia)

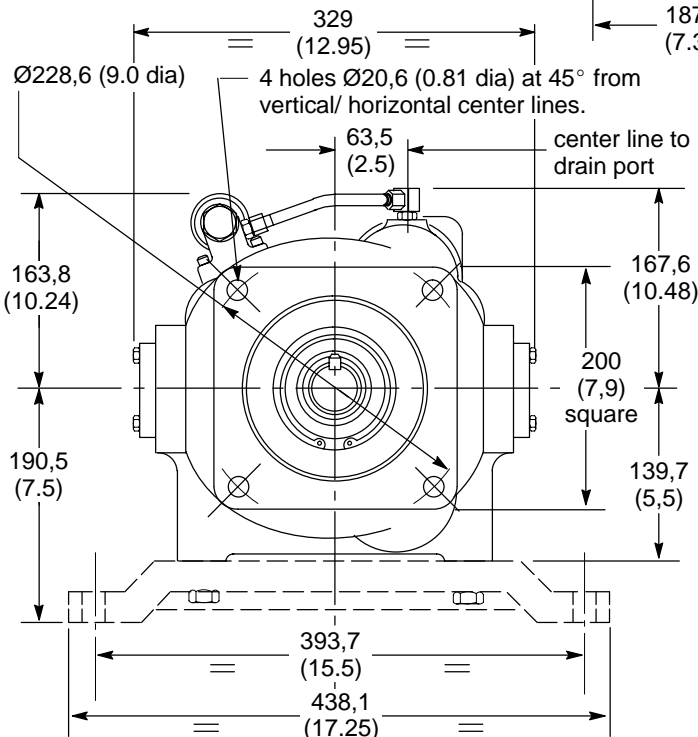

View on shaft end of pump

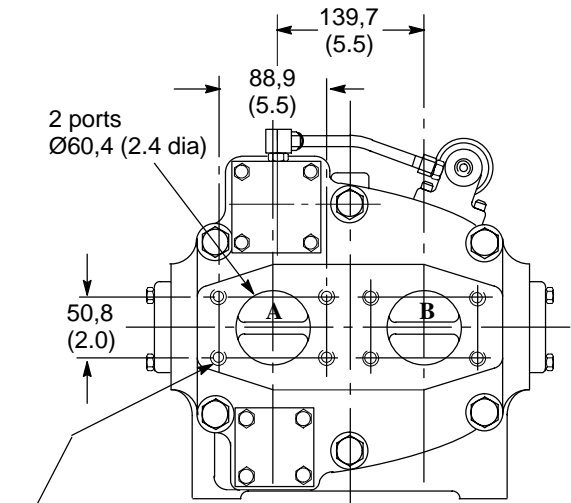

To suit SAE 4-bolt port flanges:  
8 holes .500-13 UNC 2B thread x 27,0 (1.06) deep

View on rear end of pump

Shaft rotation	Inlet port	Outlet port
RH	A	B
LH	B	A

Detail of tappings in base of pump.

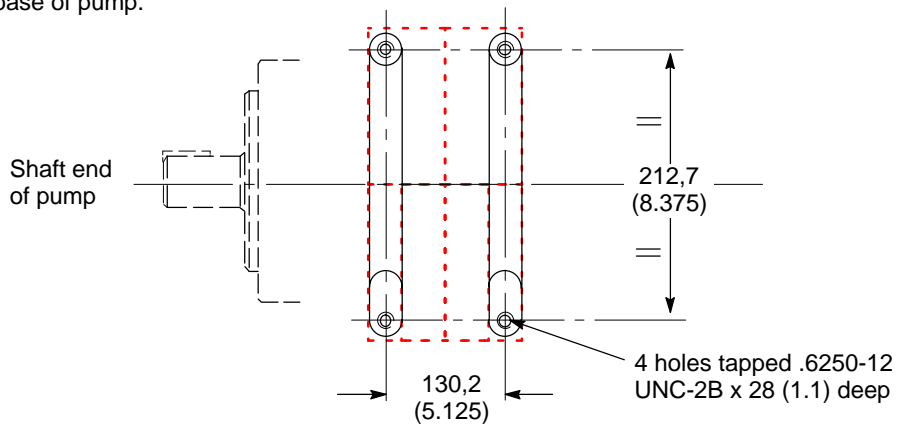

**PVB5/6, PVB 10/15 and PVB20/29 with Pressure Compensator and Adjustable Maximum Displacement Stop: Control Types “CC” and “CMC”**

For general dimensions and installation data of these pumps, see pages A.20, A.22 and A.25



Caution: While pump is operating do not back compensator adjustment screw out beyond dimension ● shown.

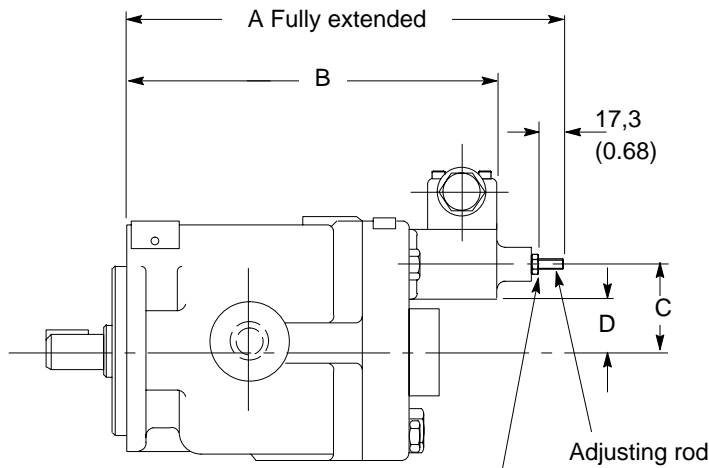

**Note.**

Compensator position for:  
 PVB5/6-*LSY* (LH rotation models) and  
 PVB10/15 -*RSY* (RH rotation models)  
 PVB20/29 -*SY* (RH and LH rotation models)

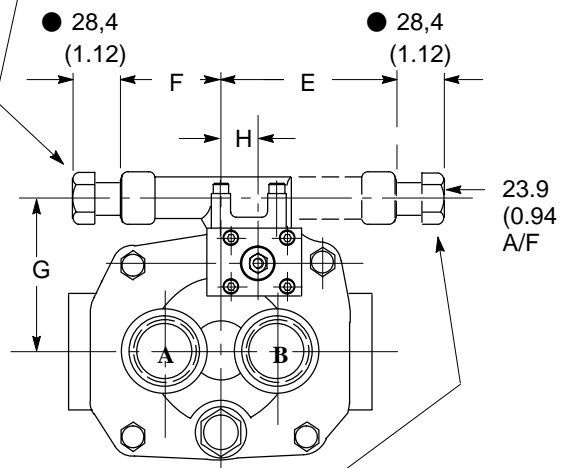

Pump type	A	B	C	D	E	F	G	H
PVB5/6	233 (9.17)	195 (7.68)	50 (1.97)	22,9 (0.9)	76,2 (3.0)	94,4 (3.72)	94,4 (3.72)	—
PVB10/15	266 (10.47)	226 (8.9)	52,3 (2.06)	25,1 (0.99)	118 (4.65)	70,8 (2.79)	90,2 (3.55)	23.8 (0.94)
PVB20/29	294 (11.56)	254 (10.0)	66,5 (2.62)	41,9 (1.65)	—	53,3 (2.1)	104,4 (4.11)	41,1 (1.62)

## PVB5 to 29 with “CG” Remote Control of Compensator

### Type “GEVS”

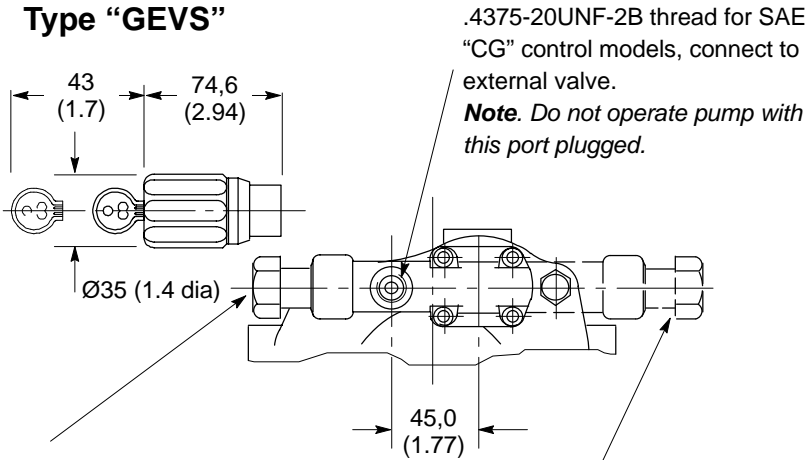

**Caution:** Effective compensator setting will be compensator control setting **plus** remote relief valve setting.

#### Adjustment procedure

1. Turn remote pressure control (such as C-175) anti-clockwise to minimum setting.
2. Turn compensator adjustment plug to desired minimum pressure - 17 bar (250 psi) or higher.
3. Full pressure range can now be obtained with remote pressure control.

Location as shown for:  
PVB5/6 LH rotation models,  
PVB10/15 RH rotation models and  
PVB20/29 LH and RH rotation models.

Location as shown in dotted outline for:  
PVB5/6 RH rotation models and  
PVB10/15 LH rotation models.

## “CVP” Load Sensing with Pressure Limiter

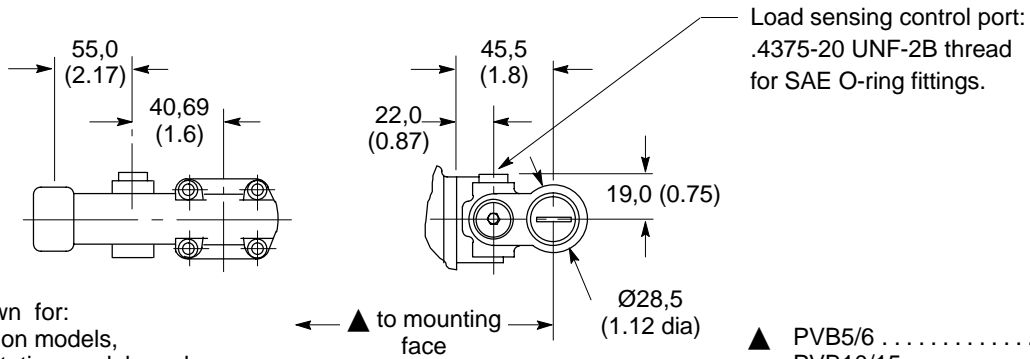

Location as shown for:  
PVB5/6 LH rotation models,  
PVB10/15 RH rotation models and  
PVB20/29 LH and RH rotation models.

▲ PVB5/6	.....	191 (7.51)
▲ PVB10/15	.....	222 (8.75)
▲ PVB20/29	.....	250 (9.84)

## Vertical “Shaft-up” Installation - “S30” Drain Port Option, for PVB5 to 29

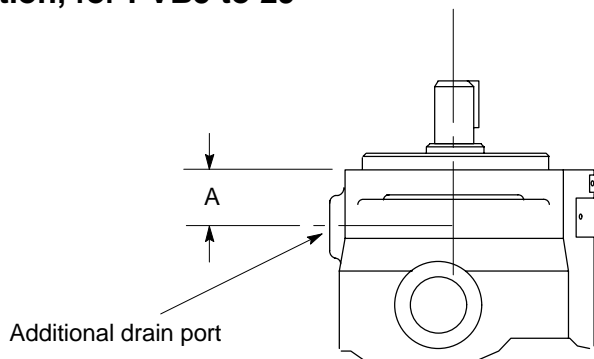

Pump type	Port tapping	A
PFB5	.562518UNF-2B	28,7 (3.85)
PVB5/6	.5625 18UNF-2B	19 (0.75)
PVB10/15	.7500 16UNF-2B	29,3 (1.15)
PVB20/29	.7500 16UNF-2B	38,9 (1.53)

# PVB5/6; PVB10/15; PVB20/29 – DIN/ISO Models

For dimensions/data not shown refer to corresponding SAE models.

## PVB5/6 – Pressure Compensated Control – “C” and “CM”

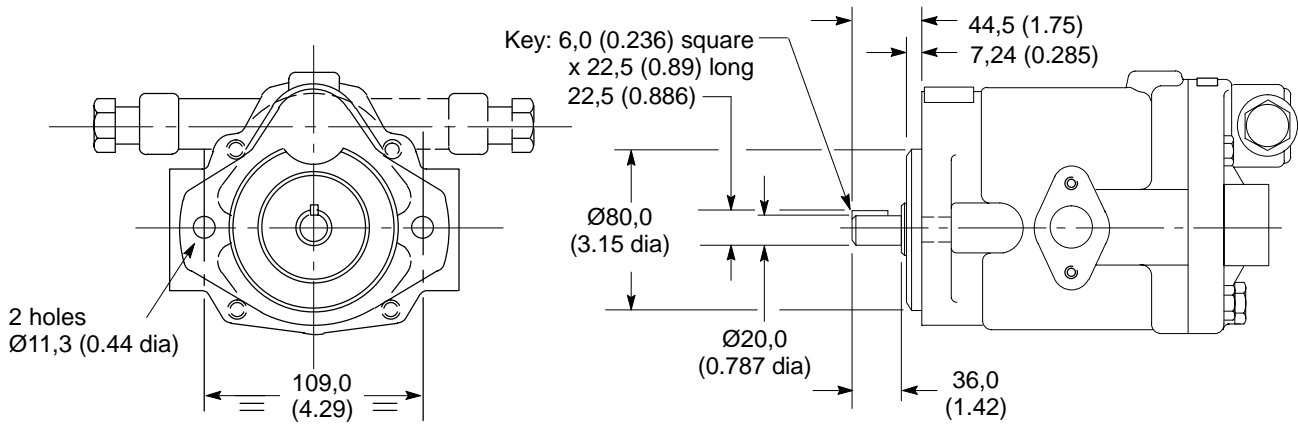

## PVB10/15 – Pressure Compensated Control – “C” and “CM”

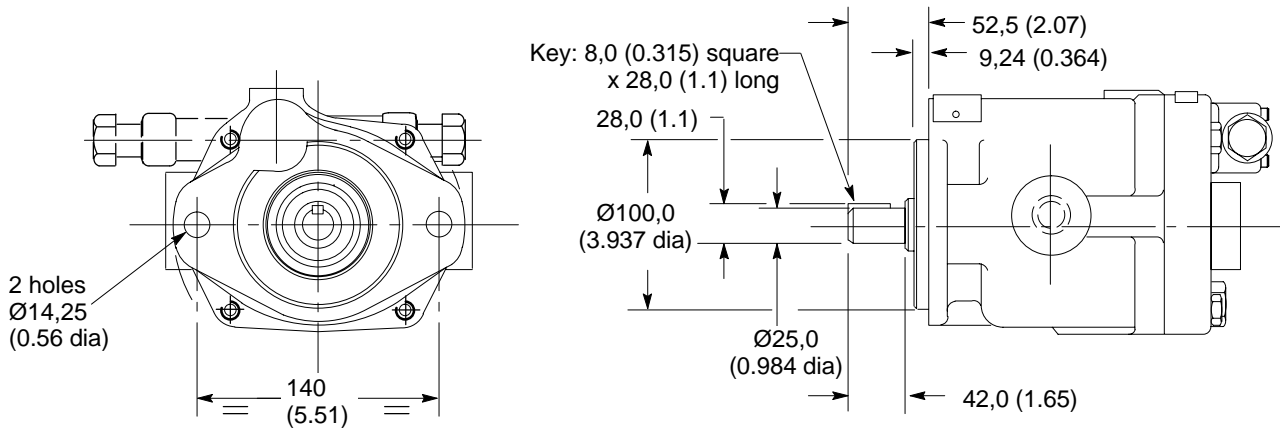

## PVB20/29 – Pressure Compensated Control – “C” and “CM”

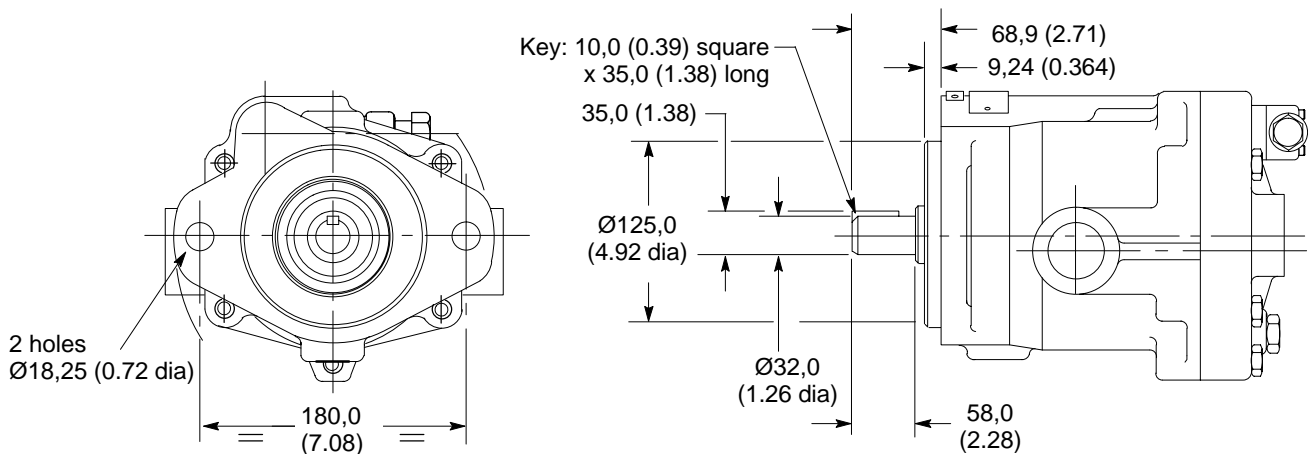



---

## Mass, approx.

### Flange Mounting Models

PFB5 .....	5 kg (11 lb)
PFB10 .....	10 kg (22 lb)
PFB20 .....	19 kg (42 lb)
PVB5/6 .....	8 kg (18 lb)
PVB10/15 .....	15 kg (33 lb)
PVB20/29 .....	26 kg (57 lb)
PVB45 .....	96 kg* (211 lb)
PVB90s .....	104 kg (230 lb)

\* Also foot mounting models.

▲ Combined foot/flange mounting models.

### Foot Bracket Kits

FB-A-10 .....	1,8 kg (4 lb)
FB-B-10 .....	2,3 kg (5 lb)
FB-C-10 .....	5,5 kg (12 lb)

## Installation Data

Horizontal mounting is recommended to maintain necessary case fluid level. Vertical "shaft-up" installation is possible with pumps ordered to include the extra drain port denoted by the "S30" feature; see "Model Code". In all cases the drain line must be full size, unrestricted and connected from the uppermost drain port directly to the reservoir in such a manner that the housing remains filled with fluid.

Piping of drain line must prevent siphoning. Pipe drain line so that it terminates below fluid level. No other lines are to be connected to this drain line.



Caution must be exercised to never exceed the following unit case pressures:

0,7 bar (10 psi) for PFB10 only.  
0,35 bar (5psi) for all other models.

## Starting

Before starting, fill case with system fluid through the uppermost drain port. Housing must be kept full at all times to provide internal lubrication. When first starting it may be necessary to bleed air from pump outlet to permit priming and to reduce noise. Bleed by loosening an outlet connection until a clear stream of fluid appears. An air bleed valve, ABS-03, is available for this purpose.

## Ordering Procedure

Before ordering, check availability with your Vickers representative.

## **CENTRALA ELBLĄG**

ul. Rawska 19B  
82-300 Elbląg

tel. /+48/ 55 625 51 00

fax /+48/ 55 625 51 01

### **Dział Handlowy**

tel. /+48/ 55 625 51 51

elblag@hydropress.pl



[www.hydropress.pl](http://www.hydropress.pl)

### **ODDZIAŁ GDAŃSK**

tel. /+48/ 55 625 51 21

fax /+48/ 55 625 51 22

### **ODDZIAŁ RUMIA**

tel. /+48/ 58 679 34 15

fax /+48/ 55 625 51 25

### **ODDZIAŁ TYCHY**

tel. /+48/ 32 787 52 88

fax /+48/ 55 625 51 38

### **ODDZIAŁ OLSZTYN**

tel. /+48/ 89 532 01 05

fax /+48/ 89 715 21 42

### **ODDZIAŁ WARSZAWA**

tel. /+48/ 22 468 86 97

fax /+48/ 55 625 51 32

### **BIURO WE WROCŁAWIU**

tel. /+48/ 782 838 000

fax /+48/ 55 625 51 35

### **BIURO W KIELCACH**

tel. /+48/ 885 995 501

fax /+48/ 55 625 51 01

### **BIURO W KRAKOWIE**

tel. /+48/ 885 995 019

fax /+48/ 55 625 51 01

### **BIURO W OPOLU**

tel. /+48/ 885 995 011

fax /+48/ 55 625 51 01

### **BIURO W BYDGOSZCZY**

tel. /+48/ 790 222 771

fax /+48/ 55 625 51 01

### **BIURO W BIAŁYMSTOKU**

tel. /+48/ 89 532 01 05

fax /+48/ 89 715 21 42

### **BIURO W ŁODZI**

tel. /+48/ 609 221 421

fax /+48/ 89 715 21 42