

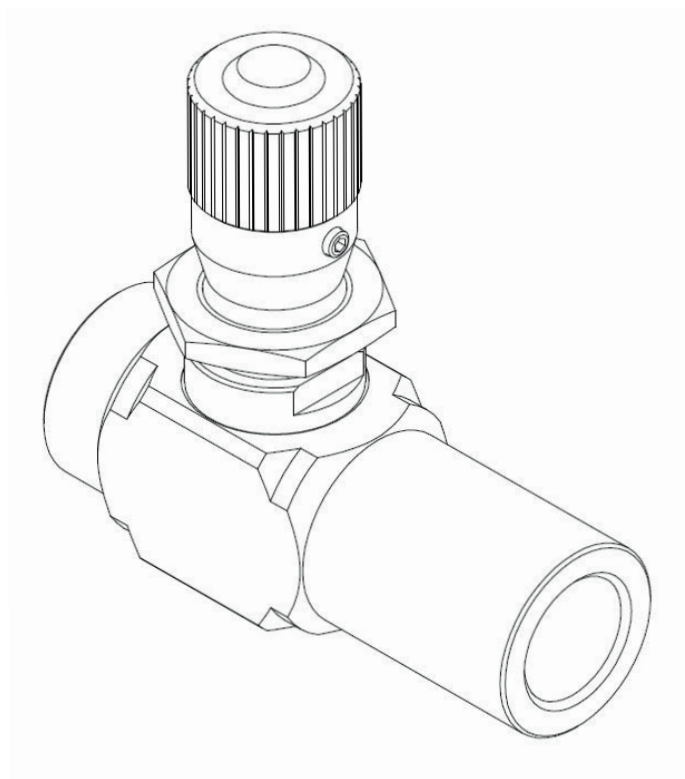

ZAWORY DŁAWIĄCE I ZWROTNO-DŁAWIĄCE

Zawory dławiące VRFU



CHARAKTERYSTYKA

| | |
|--------------------------|---------------------------------------|
| Rozmiar | 1/4" - 3/8" - 1/2" - 3/4" - 1" |
| Przepływ min/max | 15 ÷ 150 L/min |
| Ciśnienie szczytowe max. | 400 bar |
| Temperatura otoczenia | -30°C + 50°C |
| Temperatura medium | -30°C + 80°C |
| Min. zalecana filtracja | 30 |
| Waga | 0.4 ÷ 1.4 kg |

PERFORMANCE

| |
|------------------------|
| Rated size |
| Min/max flow-rate |
| Max peak pressure |
| ambient temperature |
| Oil temperature |
| Recommended filtration |
| Weight |

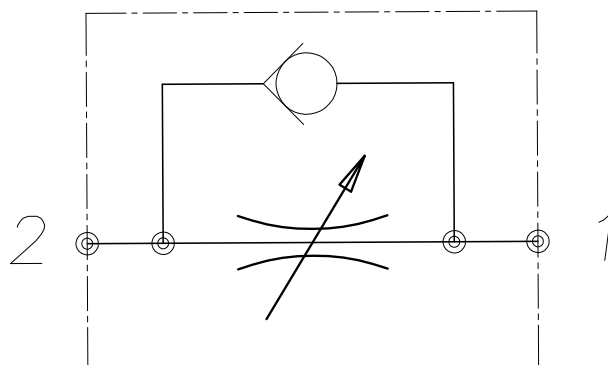

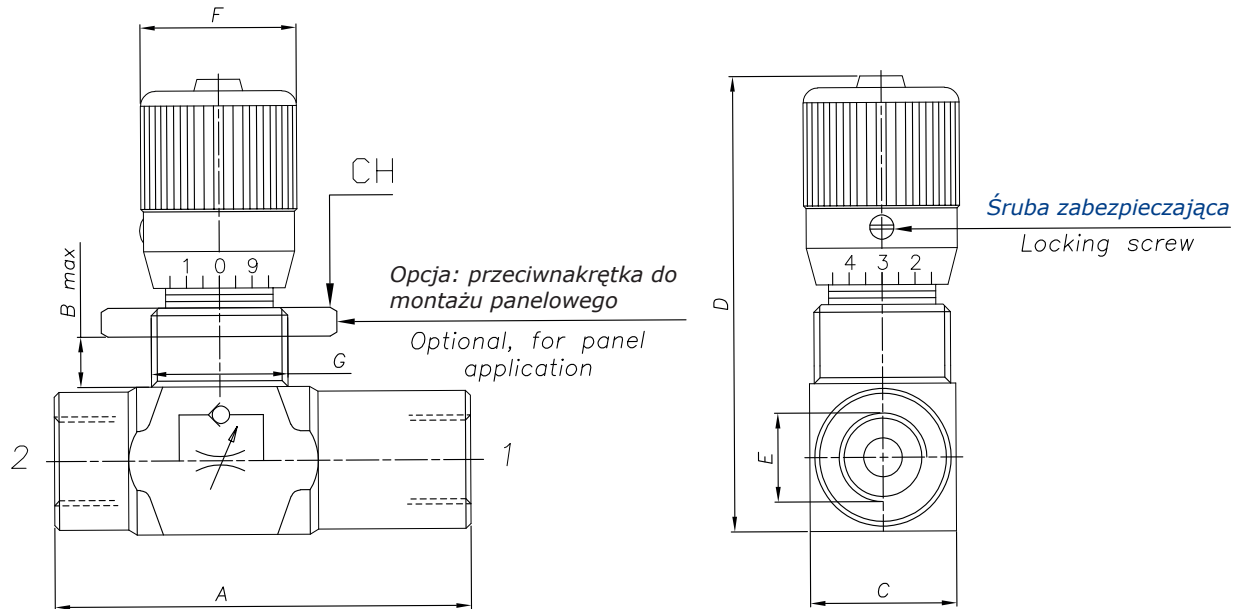

| Gwint (E) Ports (E) | Opis Description | Kod zamówienowy Ordering Code | Waga Weight | A | B | C | D | F | G | CH | Przepływ Max Flow |
|------------------------|---------------------|----------------------------------|----------------|-----|-----|----|-----|------|---------|----|----------------------|
| 1/4" GAS | VRFU-14 | 265 | 0.40 | 73 | 4.5 | 25 | 75 | 26 | M20x1.5 | 30 | 15 L/min |
| 3/8" GAS | VRFU-38 | 266 | 0.40 | 83 | 4.5 | 25 | 83 | 26 | M20x1.5 | 30 | 30 L/min |
| 1/2" GAS | VRFU-12 | 267 | 0.60 | 94 | 4.5 | 30 | 90 | 29 | M20x1.5 | 30 | 50 L/min |
| 3/4" GAS | VRFU-34 | 268 | 1.30 | 110 | 10 | 40 | 125 | 39.5 | M35x1.5 | | 80 L/min |
| 1" GAS | VRFU-100 | 269 | 1.35 | 135 | 10 | 40 | 125 | 39.5 | M35x1.5 | | 150 L/min |

BUDOWA KODU ZAMÓWIENIOWEGO HOW TO ORDER

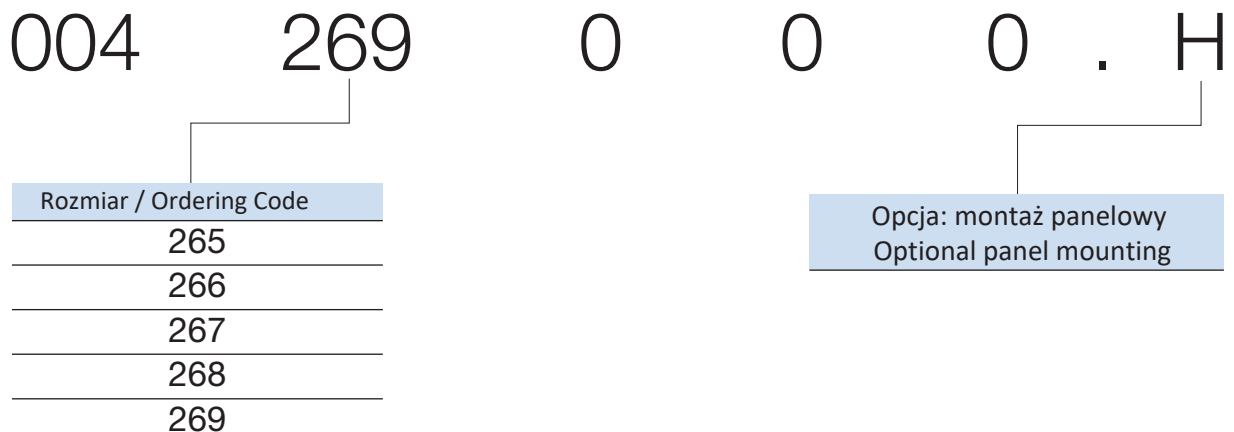

CENTRALA ELBLĄG

ul. Rawska 19B
82-300 Elbląg

tel. /+48/ 55 625 51 00

fax /+48/ 55 625 51 01

Dział Handlowy

tel. /+48/ 55 625 51 51

elblag@hydropress.pl



www.hydropress.pl

ODDZIAŁ GDAŃSK

tel. /+48/ 55 625 51 21

fax /+48/ 55 625 51 22

ODDZIAŁ RUMIA

tel. /+48/ 58 679 34 15

fax /+48/ 55 625 51 25

ODDZIAŁ TYCHY

tel. /+48/ 32 787 52 88

fax /+48/ 55 625 51 38

ODDZIAŁ OLSZTYN

tel. /+48/ 89 532 01 05

fax /+48/ 89 715 21 42

ODDZIAŁ WARSZAWA

tel. /+48/ 22 468 86 97

fax /+48/ 55 625 51 32

BIURO WE WROCŁAWIU

tel. /+48/ 782 838 000

fax /+48/ 55 625 51 35

BIURO W KIELCACH

tel. /+48/ 885 995 501

fax /+48/ 55 625 51 01

BIURO W KRAKOWIE

tel. /+48/ 885 995 019

fax /+48/ 55 625 51 01

BIURO W OPOLU

tel. /+48/ 885 995 011

fax /+48/ 55 625 51 01

BIURO W BYDGOSZCZY

tel. /+48/ 790 222 771

fax /+48/ 55 625 51 01

BIURO W BIAŁYMSTOKU

tel. /+48/ 89 532 01 05

fax /+48/ 89 715 21 42

BIURO W ŁODZI

tel. /+48/ 609 221 421

fax /+48/ 89 715 21 42