

SILNIKI HYDRAULICZNE

SILNIKI TŁOKOWE O STAŁYM WYDATKU

SERIA 741XX, 743XX, 746XX

Fixed Displacement Motors

Features & Benefits

- Compact - Ease of Installation
- Efficient axial piston design
- Numerous Options - Shafts, Ports, Shuttle Valves, Speed Pickup
- Wide Displacement range: 9.8 cc (0.60 cid) to 82.6 cc (5.04 cid)
- Optional shuttle, back pressure valve - improved loop cooling, flushing
- Optional Speed Sensor Available (9 pulse/rev.) - 50 RPM min
- Good in reliability & performance
- Worldwide sales & services

2 Bolt SAE "A" Mount - 741XX Series

9.8 cm³/r [.60 in³/r] Displacement

20.3 cm³/r [1.24 in³/r] Displacement



2 Bolt SAE "B" Mount - 743XX Series

32.9 cm³/r [2.01 in³/r] Displacement

40.6 cm³/r [2.48 in³/r] Displacement

49.2 cm³/r [3.00 in³/r] Displacement



2 Bolt SAE "B-B" Mount - 746XX Series

82.6 cm³/r [5.04 in³/r] Displacement



Model 741XX Fixed Displacement Motor

2 Bolt SAE A Mount

9.8 cm³/r [.60 in³/r] Displacement

20.3 cm³/r [1.24 in³/r] Displacement

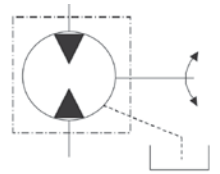

Identification numbers – Fixed Displacement Motor - Closed Circuit
Stamped on each unit.

7 4 1 X X - D A A - 0 1
 A B C D

A – Product Number Description

74111 = 12.3 cm³/r [0.75 in³/r]

74115 = 16.6 cm³/r [1.01 in³/r]

74118 = 20.3 cm³/r [1.24 in³/r]

74119 = 9.8 cm³/r [.60 in³/r]

74148 = 20.3 cm³/r [1.24 in³/r] with Thru Shaft Back-plate

74149 = 12.3 cm³/r [0.75 in³/r] with Thru Shaft Back-plate

B – Rotation

D = Dual

C – Sequential Letter

D – Design Code number



Serial Number Code

10 05 06 XXX 1 000

Last Two Digits of Year Built. (10 for 2010 etc.)

Month Built (two digits)

Day Built (two digits)

Specific Number of the Pump

Shift Number

Manufacturing Cell

TYPICAL PRODUCT NUMBER

MODEL CODE

74111-DAC-01	AAVAAA0B000A0B
74111-DAF-01	AAVAEAA0B000A0B
74118-DAJ-01	AAVAAA00000A0B
74118-DAS-01	AAVAAAB00000A0B

SPECIFICATIONS

MODEL 74111/74119

MODEL 74118/74148

Maximum Displacement	12.3 cm ³ /r [.75 in ³ /r]	20.3 cm ³ /r [1.24 in ³ /r]
Maximum Rated Speed	4500 RPM	3600 RPM
Nominal Pressure Rating †	350 bar [5076 lbf/in ²]	350 bar [5076 lbf/in ²]
Peak Pressure Rating ††	370 bar [5400 lbf/in ²]	370 bar [5400 lbf/in ²]
Input Flow at Rated Speed and Pressure	66.37 l/min [14.6 GPM]	87.74 l/min [19.3 GPM]
Output Power at Rated Speed and Pressure	32.30 kW [43.28 hp]	42.65 kW [57.25 hp]
Output Torque at Rated Speed and Pressure	68.55 N•m [606.21 lbf•in]	113.14 N•m [1002.27 lbf•in]
Continuous Allowable Case Pressure	1.7 bar [25 lbf/in ²]	1.7 bar [25 lbf/in ²]
Continuous Inlet Temperature	107° C [225° F]	107° C [225° F]
Weight/Single Motor (approximate)	4.9 kg [11 lbs]	4.9 kg [11 lbs]

† Nominal Pressure: Max. delta system pressure at which component fatigue does not occur (motor life estimated by bearing life).

†† Peak Pressure: Max. operation pressure which is permissible for a short duration of time (t < 1 sec).

Model 741XX Fixed Displacement Motor

Compact axial piston design with de-stroked 9.8, 12.3, 14.96, 16.6 & 20.3 cm³/r displacement options. Uses lightweight aluminum housing & end cover with same side & opposite side porting options. Numerous output shafts with through drive capabilities for brake mounting.

End cover houses main ports and gauge ports. Improved thrust load capacities.* Attached cross section view shows major components of the motor.

*Contact Eaton representative.

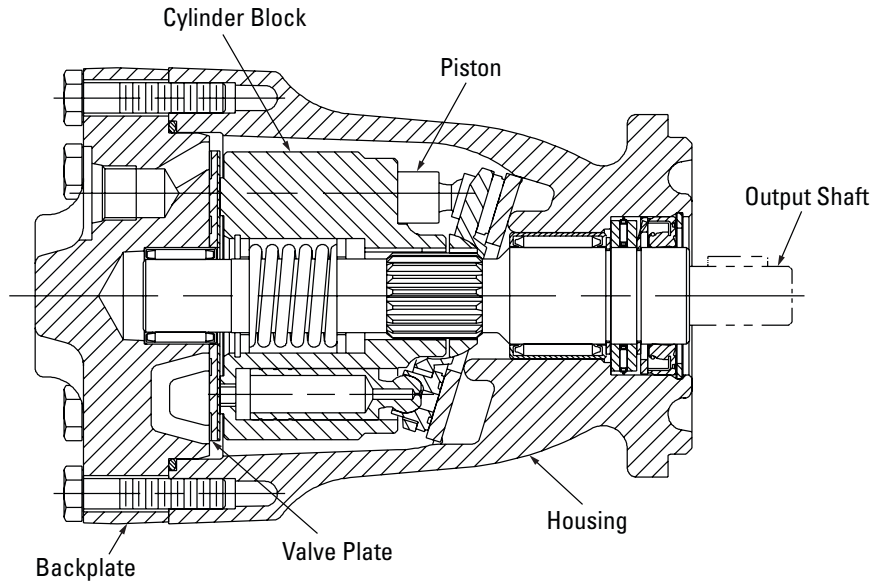

Model 741XX Fixed Displacement Motor

Model Code

12.3 cm³/r [.75 in³/r] Displacement

20.3 cm³/r [1.24 in³/r] Displacement

Fixed displacement piston motors are specified by the following model code. Once a motor is built from the model code, a product number will be assigned to that configuration.

Make sure all positions are selected within the 15 digit code for each motor.

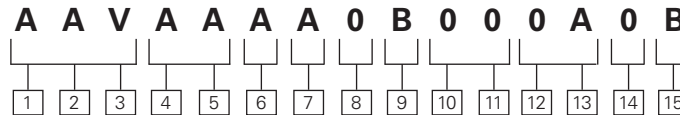

1 2 3 Code Title

AAV - 20.3 cm³/r [1.24 in³/r]
Fixed displacement piston motor frame size

4 5 Output Shaft

AA - 13 Tooth 16/32 spline with snap ring groove, min. full spline 22.1 [.87], shaft extension 41.1 [1.62], (std.)
AE - Straight shaft, dia. 22.2[.875], keyway 6.35 [.25] x 25.4[1.00], shaft extension 41.1 [1.62] (key included), (std.)
AH - Diameter 22.3 [.88] taper .125:1, keyway 6.35 X 25.4 [.25 X 1.00], .625-18 UNF-2A, shaft extension 66.5 [2.62] (key included)

6 Main Port, Size, & Location

A - 1-1/16-12 UN-2B straight thread O-ring ports opposite sides, (std.)
B - 1-1/16-12 UN-2B straight thread O-ring ports- rear, (std.)
C - 1-1/16-12 UN-2B straight thread O-ring ports- same side, only with through shaft, (opt.)
D - .875-14 UNF-2B SAE O-ring ports opposite sides

7 Drain Port, Size, & Location

A - 9/16-18 UNF-2B straight thread O-ring port - upper rear, (std.)
B - 9/16-18 UNF-2B straight thread O-ring port - lower rear, (std.)
C - 9/16-18 UNF-2B straight thread O-ring port - bottom rear, with through shaft only (pos. 8, selection 1), (std.)

8 Auxiliary Mounting Features (rear)

0 - No Auxiliary Mounting Feature
1* - Straight through shaft, dia. 19 [.75], with keyway 4.8 x 31 [.189 x 1.22], 209.3 [8.42] from mounting flange (Key included), 5/16 - 18 UNC-2B mounting holes 14.2 [.56] deep min. full thread, (opt.)

Note: Requires the selection in position 6 of same side porting. (opt.)

9 Displacement Options

0 - As given in code title. - Model 74118 or 74148, (std.)
A - 16.6 cm³/r [1.01 in³/r] destroked from 20.3 cm³/r [1.24 in³/r], (opt.)
B - 12.3 cm³/r [.75 in³/r] destroked from 20.3 cm³/r [1.24 in³/r] - Model 74111 or 74149, (std.)
C - 9.8 m³/r [.60 in³/r] destroked from 20.3 cm³/r [1.24] in³/r, (opt.)
D - 14.96 m³/r [.91 in³/r] destroked from 20.3 cm³/r [1.24] in³/r, (opt.)

10 11 Special Features

00 - No Special Features, (std.)
AF - Reduced drive shaft end play, Internal case drain with check, 2 degree valving, and no drive shaft key
AK - Rotating group and bearing for high speed application
AR - 5000 rpm speed rating and components (for 20.3 cc)

12 13 Paint

0A - Primer, (std.)
0B - Black Paint, (std.)

14 Identification

0 - Standard, (std.)

15 Design Code

B - Valve Plate

Model 74111 & 74118 Fixed Displacement Motor

Output Shafts and Installation Drawings

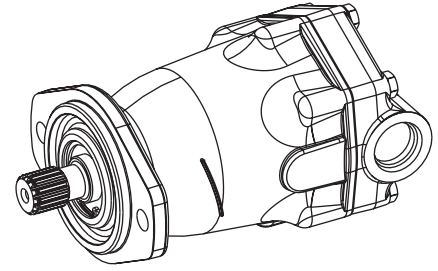

Output Shaft

Used For All 741XX Models

(Code Position 4, 5)

Splined Shaft Selection AA

Maximum Torque on Shaft
209.3 N-m [1,852 lbf-in]

Keyed Shaft Selection AE

Maximum Torque on Shaft
209.3 N-m [1,852 lbf-in]

Keyed Shaft Selection AH

Maximum Torque on Shaft
209.3 N-m [1,852 lbf-in]

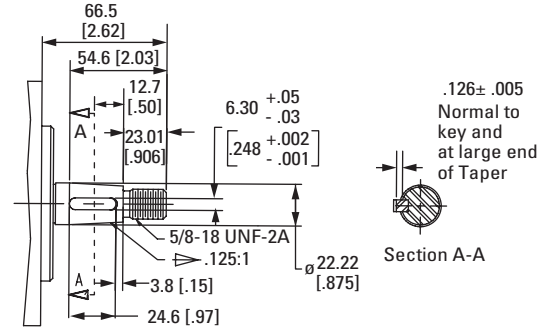
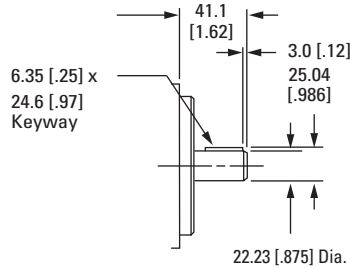
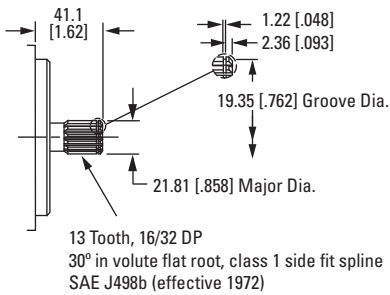

Installation Drawing

Opposite Side Porting

(Code position 6, Selection A)

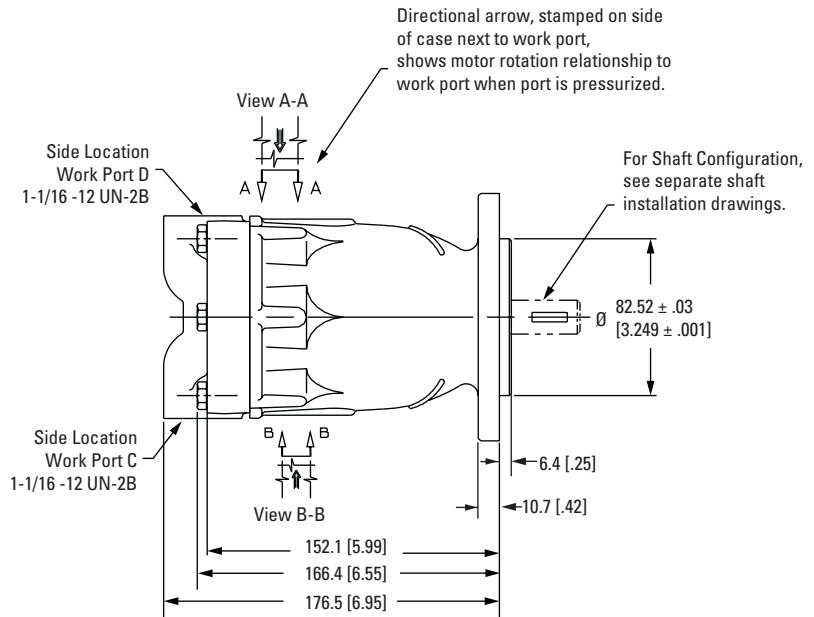
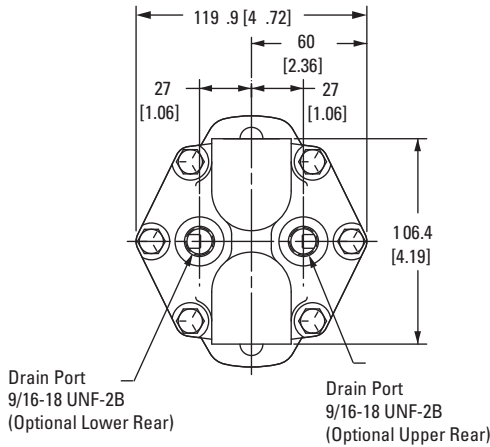

Note: All ports are SAE (J1926) O-ring ports. Dimensions are in millimeters [inches], unless otherwise specified.

Model 74148 & 74149 Fixed Displacement Motor

Installation Drawings

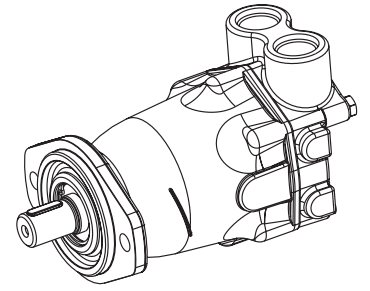

Rear Porting

(Code position 6, Selection B)

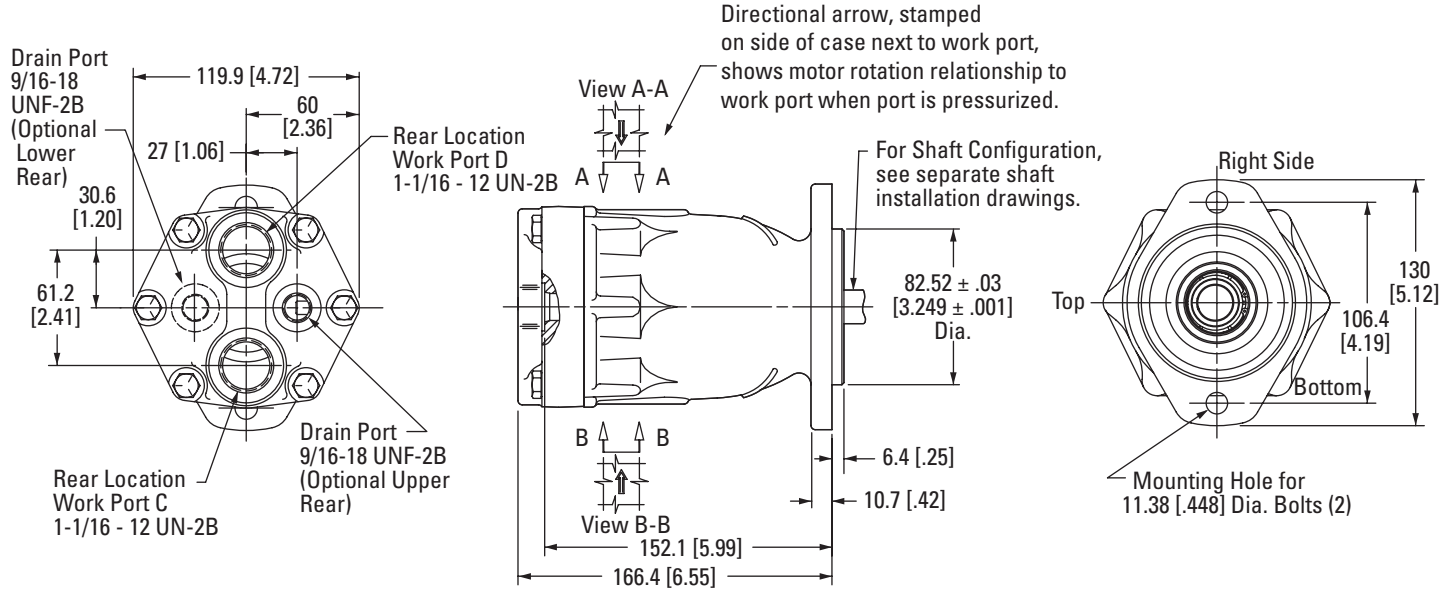

Through Shaft and Same side porting

(Code position 6, Selection C)

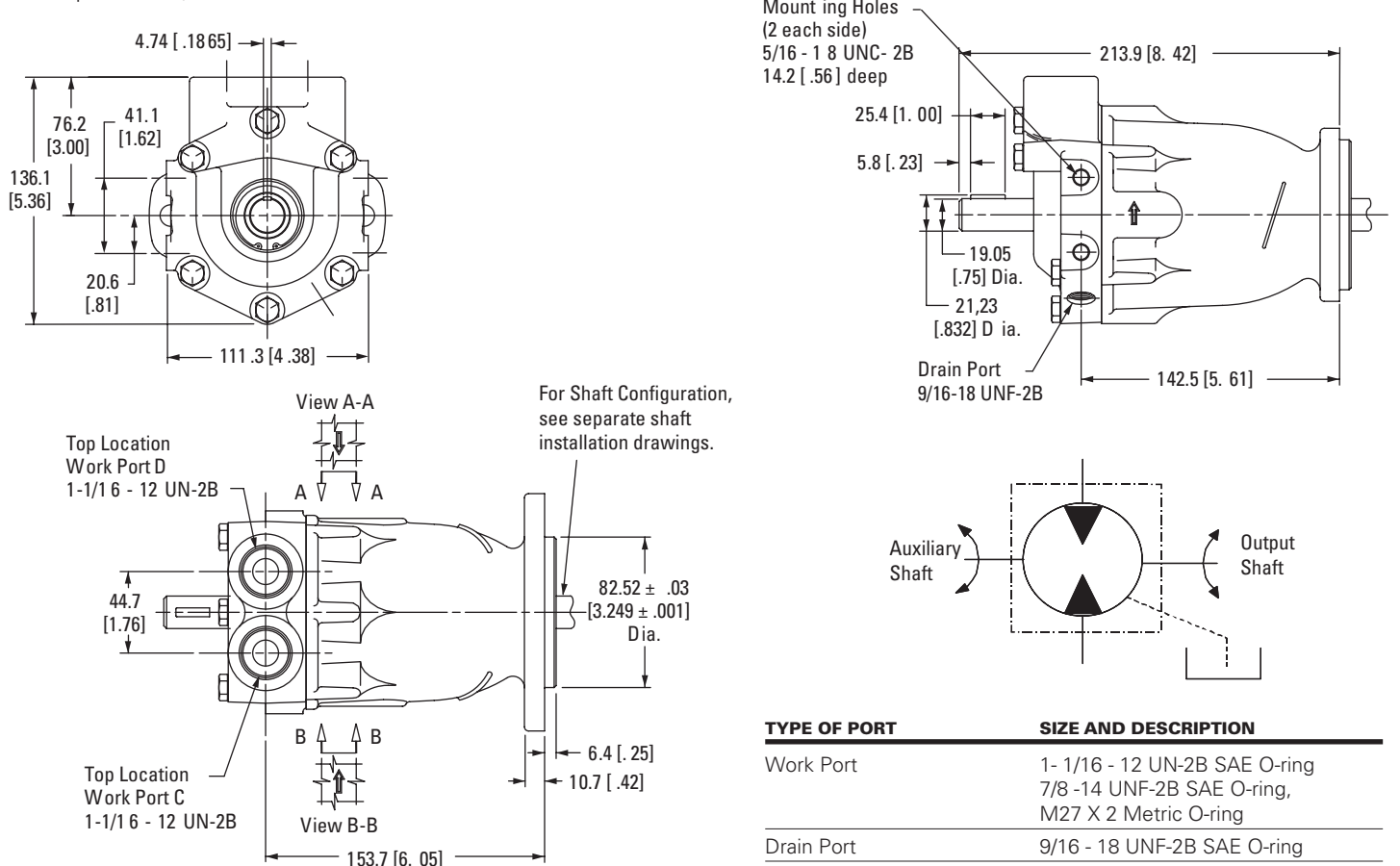

Note: All ports are SAE (J1926) O-ring ports. Dimensions are in millimeters [inches], unless otherwise specified.

Model 743XX Fixed Displacement Motor

2 Bolt SAE B Mount

24.6 cm³/r [1.50 in³/r] Displacement

40.6 cm³/r [2.48 in³/r] Displacement

49.2 cm³/r [3.00 in³/r] Displacement

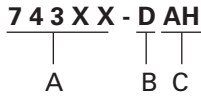

Identification numbers – Fixed Displacement Motor - Closed Circuit
Stamped on each unit.

A – Product Number Description

74315 = 32.9 cm³/r [2.01 in³/r]

74318 = 40.6 cm³/r [2.48 in³/r]

74328 = 49.2 cm³/r [3.00 in³/r]

74348 = 40.6 cm³/r [2.48 in³/r] with thru shaft backplate

B – Rotation

D = Dual

C – Sequential Letter

Serial Number Code

10 05 06 XXX 1 000

Last Two Digits of Year Built. (10 for 2010 etc.)

Month Built (two digits)

Day Built (two digits)

Specific Number of the Pump

Shift Number

Manufacturing Cell

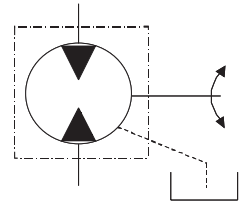

TYPICAL PRODUCT NUMBER	MODEL CODE
74315-DAL	AAJAADB0AAD0A0B
74318-DAA	AAJAADA00000A0B
74318-DAB	AAJAABA00000A0B
74328-DAA	AAKABAJ00000A0B
74328-DAB	AAKAAAB0000000B



SPECIFICATIONS	MODEL 74315	MODEL 74318/74348	MODEL 74328
Maximum Displacement	32.9 cm ³ /r [2.01 in ³ /r]	40.6 cm ³ /r [2.48 in ³ /r]	49.2 cm ³ /r [3.0 in ³ /r]
Maximum Rated Speed	3600 RPM	3600 RPM	3000 RPM
Nominal Pressure Rating †	350 bar [5000 lbf/in ²]	350 bar [5000 lbf/in ²]	315 bar [4570 lbf/in ²]
Peak Pressure Rating ††	370 bar [5400 lbf/in ²]	370 bar [5400 lbf/in ²]	345 bar [5000 lbf/in ²]
Input Flow at Rated Speed and Pressure	142.43 l/min [31.33 GPM]	175.71 l/min [38.65 GPM]	177.12 l/min [38.96 GPM]
Output Power at Rated Speed and Pressure	69.13 kW [92.80 hp]	85.30 kW [114.50 hp]	77.53 kW [104.61 hp]
Output Torque at Rated Speed and Pressure	183.36 N•m [1624.64 lbf•in]	226.27 N•m [2004.54 lbf•in]	246.78 N•m [2197.68 lbf•in]
Continuous Allowable Case Pressure	1.7 bar [25 lbf/in ²]	1.7 bar [25 lbf/in ²]	1.7 bar [25 lbf/in ²]
Continuous Inlet Temperature	107° C [225° F]	107° C [225° F]	107° C [225° F]
Weight/Single Motor (approximate)	9.1 kg [20 lbs]	9.1 kg [20 lbs]	9.1 kg [20 lbs]

† Nominal Pressure: Max delta system pressure at which component fatigue does not occur (motor life estimated by bearing life).

†† Peak Pressure: Max operation pressure which is permissible for a short duration of time (t < 1 sec).

Model 74315 Fixed Displacement Motor

Compact axial piston design with de-stroked 24.6, 29.5, 32.9, 40.6 and 49.3 cm³/r displacement options. Uses lightweight aluminum housing with speed sensor mounting option. End cover with same side, rear side & opposite side working ports. Numerous output shafts with through drive capabilities for brake mounting. End cover houses main

ports, gauge ports, shuttle valve back pressure relief valve. Improved thrust load capacities.*

Attached cross section view shows major components of the motor.

*Contact Eaton representative.

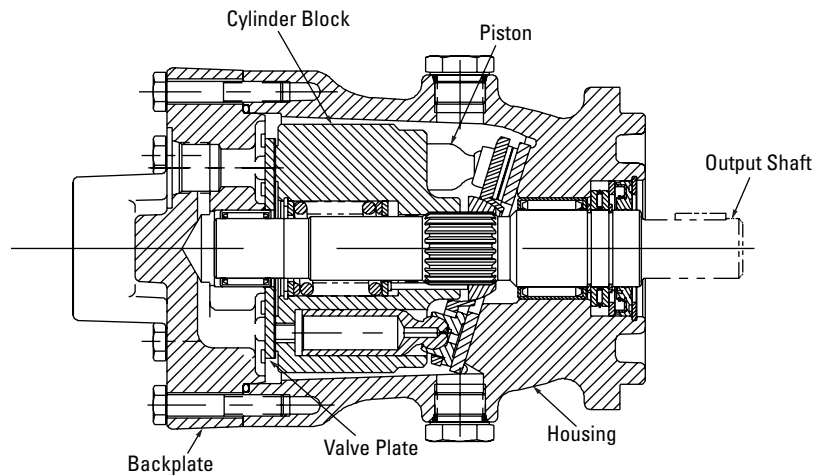

Model 743XX Fixed Displacement Motor

Model Code

2 Bolt SAE B Mount

32.9 cm³/r [2.01 in³/r] Displacement

40.6 cm³/r [2.48 in³/r] Displacement

49.2 cm³/r [3.00 in³/r] Displacement

Fixed displacement piston motors are specified by the following model code. Once a motor is built from the model code, a product number will be assigned to that configuration.

Make sure all positions are selected within the 15 digit code for each motor.

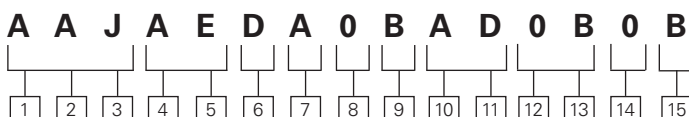

1 2 3 Code Title

AAJ - 40.6 cm³/r [2.48 in³/r]

Fixed displacement piston motor frame size

AAK - 49.2 cm³/r [3.0 in³/r]

Fixed displacement piston motor frame size

4 5 Output Shaft

AA - 13 Tooth 16/32 spline shaft extension 41.1 [1.62], (std.)

AB - 15 Tooth 16/32 spline, shaft extension 46 [1.81], (opt.)

AD - Straight Shaft, dia. 28.58 [1.125], keyway 7.9 [.31] x 32.5 [1.28], shaft extension 46 [1.81] (key included), (opt.)

BF - Straight shaft, dia 22.23 [.875], keyway 6.4 X 55.6 [.25 X 2.19], shaft extension 71.4 [2.81] (Key included)

6 Main Port, Size, & Location

A - 1-1/16-12-12 UN-2B straight thread O-ring ports- opposite sides, (opt.)

B - 1-5/16-12 UN-2B straight thread O-ring ports- opposite sides, (std.)

C - 1-5/16-12 UN-2B straight thread O-ring ports- rear, (std.)

D - 1-5/16-12 UN-2B straight thread O-ring ports- same side, Top, (opt.)

E - 1-1/16-12 UN-2B straight thread O-ring ports- rear, (opt.)

J - 1-1/16-12 UN-2B straight thread O-ring ports- same side, Top, (opt.)

M - M33 X 2 Metric O-ring ports - Top

7 Drain Port, Size, & Location

A - 3/4-16 UNF-2B straight thread O-ring port - Top of Housing, (std.)

B - 3/4-16 UNF-2B straight thread O-ring port - Top and bottom of Housing, bottom plugged, (opt.)

G - 3/4-16 UNF-2B straight thread O-ring port - upper rear of Backplate, (opt.)

J - 9/16-18 UNF-2B straight thread O-ring port-upper rear of Backplate, (opt.)

8 Auxiliary Mounting Features (rear)

0 - No Auxiliary Mounting Feature (std.)

3* - Straight through shaft, dia. 22.23 [.875], with keyway 4.75 x 26.9 [.187 x 1.06] (key included, 19 [.75] long). Side Mounting Pad holes both sides, 4 x .3125- 18.

***Note:** Requires the selection in position 6 of same side porting. (opt.)

9 Displacement Options

0 - As given in code title, 40.6 cm³/r [2.48 in³/r] - Model 74318 or 74348, (std.)

A - 32.9 cm³/r [2.01 in³/r] destroyed from 40.6 cm³/r [2.48 in³/r] - Model 74315, (opt.)

B - 24.6 cm³/r [1.50 in³/r] destroyed from 40.6 cm³/r [2.48], (opt.)

C - 29.5 cm³/r [1.80 in³/r] Modified from A 40.6 cm³/r [2.48 in³/r]

10 11 Special Features

00 - No special feature, (std.)

AD - Shuttle Valve and Charge Pressure Valve set at 15-17 bar [220- 250 lbf/in²], (opt.)

AM - Shuttle Valve and Charge Pressure Valve set at 10-12 bar [150- 175 lbf/in²], (opt.)

AN - Speed sensor magnetic pickup (9 Pulse), 3 pin weather pack connector with 127 [5.0] lead wire

AP - Speed sensor magnetic pickup (9 Pulse), 3 pin metri-pack connector with 127 [5.0] lead wire

AY - 6.20 bar [90.0 lbf/in²] Static seal with adaptor and unidirectional RH (CW) rotation with anti-cavitation check valve

AZ - 2 Way shuttle valve with back-pressure valve set at 5.2-7.2 bar [75-105 lbf/in²]; viton drive shaft seal

BF - 6.20 bar [90.0 lbf/in²] Static seal with adapter and unidirectional LH (CCW) rotation with anti-cavitation check valve

BU - Polyacrylate drive shaft seal

CT - Cast iron housing , shuttle valve and orificed back pressure valve set at 14.8-16.2 bar [215-235 lbf/in²], 1.0-1.5 gal/min flow to case , and 2X M12 X 1.5 metric O-ring diagnostic ports (position 9 should have "0")

12 13 Paint

0A - Primer, (std.)

0B - Black Paint, (std.)

14 Identification

0 - Standard, (std.)

15 Design Code

B - Valve Plate

Model 74315, 74318 and 74328 Fixed Displacement Motor

Output Shafts

Used for all 743XX Models

(Code position 4, 5)

Spline Shaft

Selection AA

Maximum Torque on Shaft
209.3 N•m [1,852 lbf•in]

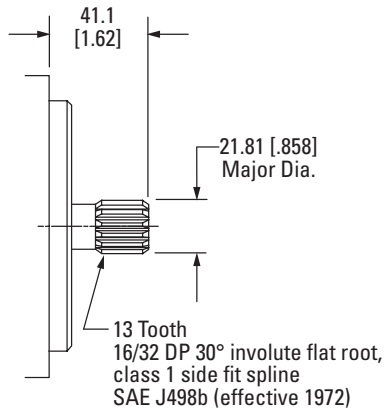

Spline Shaft

Selection AB

Maximum Torque on Shaft
337.5 N•m [2,987 lbf•in]

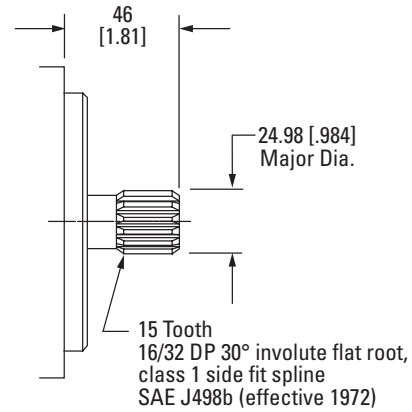

Straight Shaft

Selection AD

Maximum Torque on Shaft
337.5 N•m [2,987 lbf•in]

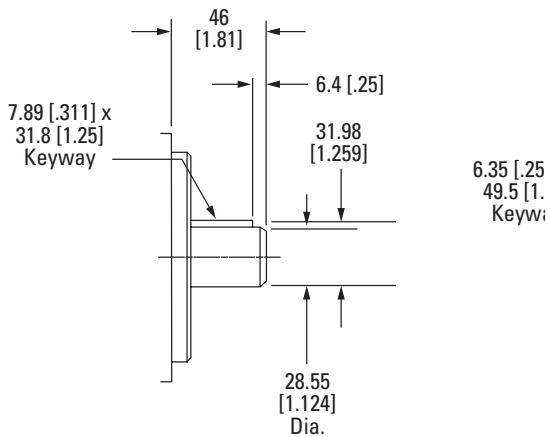

Spline Shaft

Selection BF

Maximum Torque on Shaft
209.3 N•m [1,852 lbf•in]

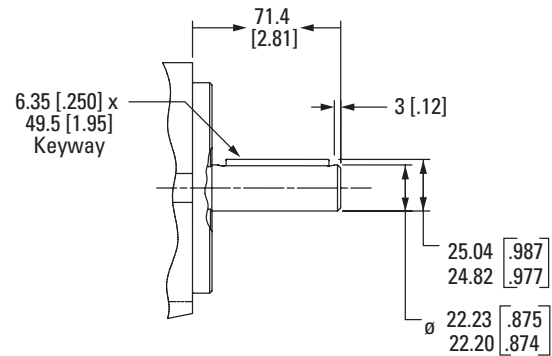

Note: Dimensions are in millimeters [inches], unless otherwise specified.

Model 74315, 74318 and 74328

Fixed Displacement Motor

Installation Drawings

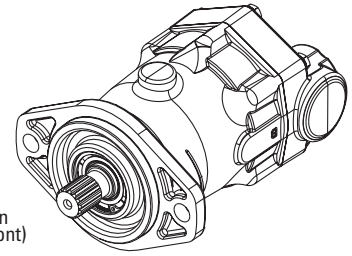

Opposite Side Porting

(Code position 6, selection A or B)

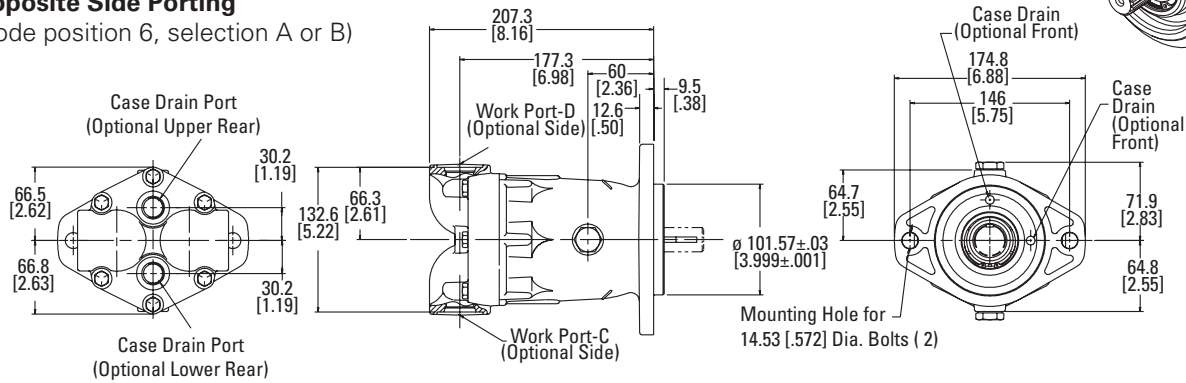

Rear Porting

(Code position 6, selection C)

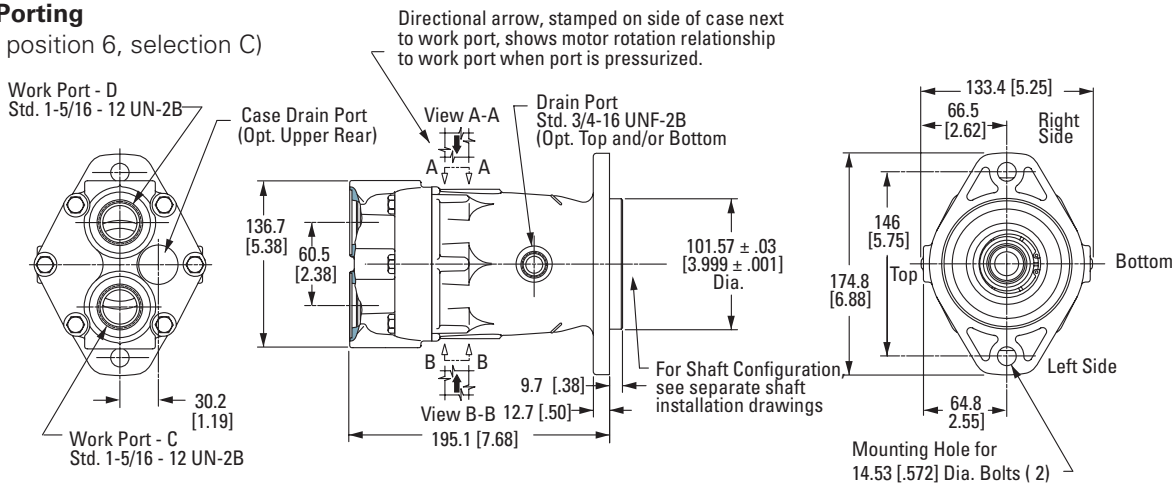

Same Side Porting

(Code position 6, selection D)

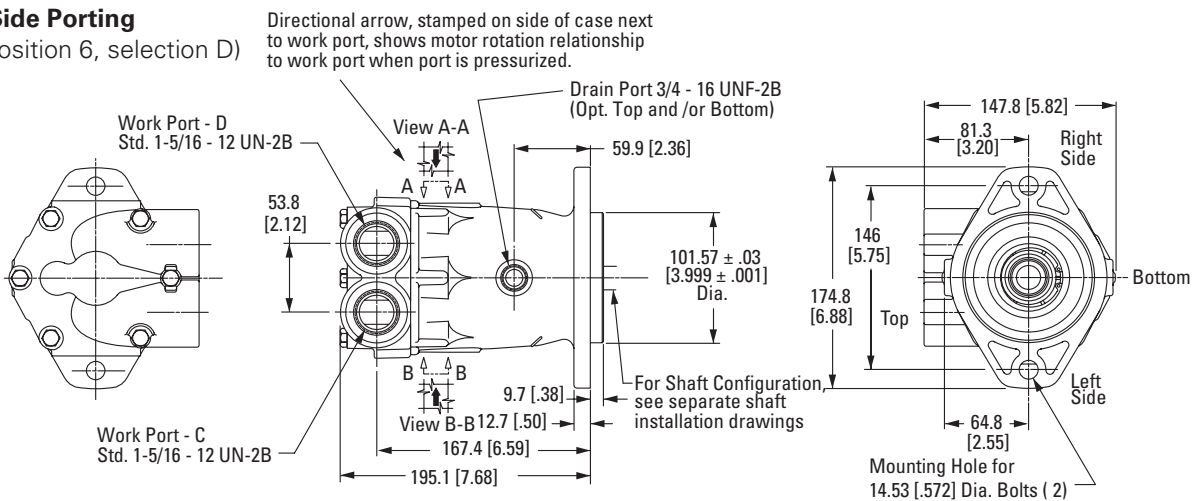

TYPE OF PORT	SIZE AND DESCRIPTION
Work Port	1- 1/16 - 12 UN-2B SAE O-ring
	1- 5/16 - 12 UN-2B SAE O-ring
	M33 X 2 Metric O-ring
	G1 BSPP Straight thread
Drain Port	3/4 - 16 UNF-2B SAE O-ring
	7/8-14 UNF-2B SAE O-ring
	9/16 -18 UNF-2B SAE O-ring
	M18 X 1.5 Metric O-ring port
	G 38 BSPP Straight Thread

Note: All ports are SAE (J1926) O-ring ports. Dimensions are in millimeters [inches], unless otherwise specified.

Model 74348 Fixed Displacement Motor

Installation Drawings

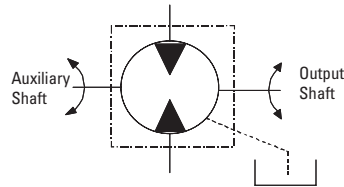
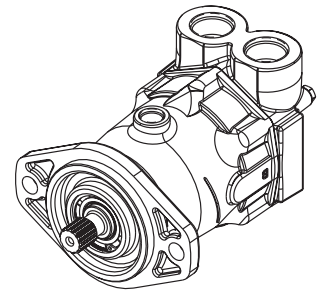

Same Side Porting with Through shaft for brake mounting

(Code position 6, selection D)

(Code position 8, selection 3)

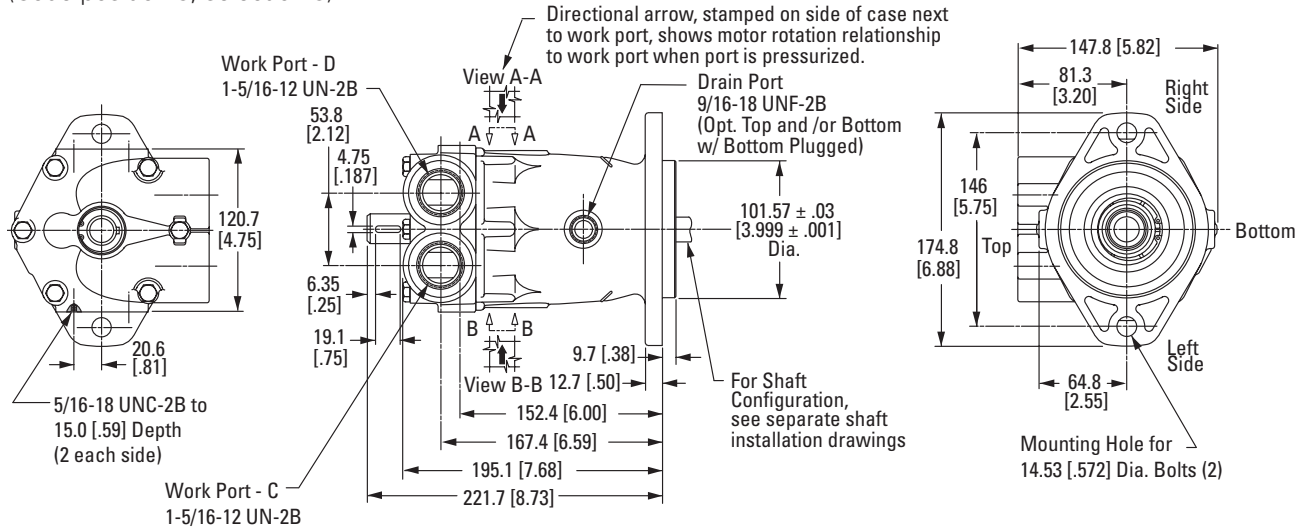

TYPE OF PORT	SIZE AND DESCRIPTION
Work Port	1- 1/16 - 12 UN-2B SAE O-ring
	1- 5/16 - 12 UN-2B SAE O-ring
Drain Port	3/4 - 16 UNF-2B SAE O-ring
	7/8-14 UNF-2B SAE O-ring
	9/16 - 18 UNF-2B SAE O-ring
	M18 X 1.5 Metric O-ring
	G 3/8 BSPP straight Thread

743XX Motor

Anti-Cavitation Check Valve

Position 10, 11

Anti-Cavitation check valve is used for application such as Fan drive control. When there is a need to reduce the motor speed during operation, the pump flow to motor is reduced, but due to the inertia of the load (Fan), the motor still runs at certain high speed. It is for a very short period of time.

This causes motor to suck more oil from pump port and may lead to cavitation in pump high pressure line.

To avoid this, oil from the low pressure side of the motor is circulated to the its high pressure side. A check valve is installed to connect the two motor ports.

Selection AY

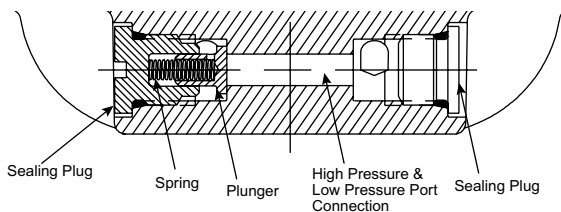

Selection BF

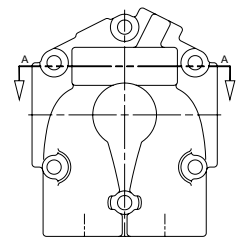
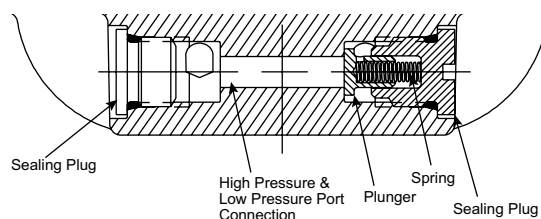

Note: All ports are SAE (J1926) O-ring ports. Dimensions are in millimeters [inches], unless otherwise specified.

Model 74315, 74318 and 74328 Fixed Displacement Motor

Installation Drawings

Same Side Porting with Shuttle Valve and Charge Pressure Relief Valve

(Code position 10, 11 selection AD or AM)

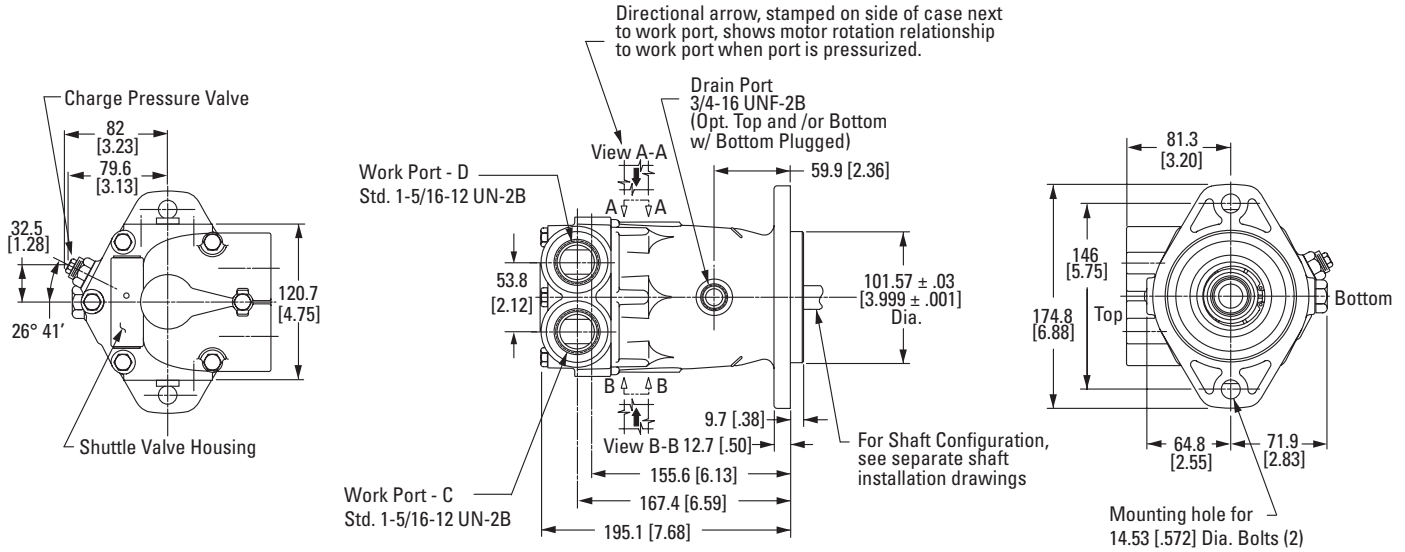
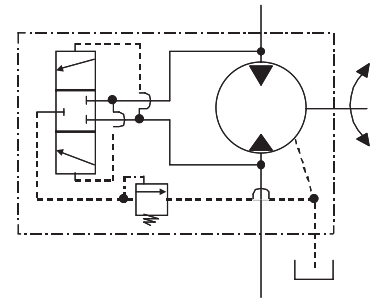

TYPE OF PORT	SIZE AND DESCRIPTION
Work Port	1- 1/16 - 12 UN-2B SAE O-ring
	1- 5/16 - 12 UN-2B SAE O-ring
	M33 X 2 Metric O-ring
Drain Port	3/4 - 16 UNF-2B SAE O-ring
	7/8-14 UNF-2B SAE O-ring
	9/16 - 18 UNF-2B SAE O-ring
	M18 X 1.5 Metric O-ring port

Model 74315, 74318 and 74328 Fixed Displacement Motor

Shuttle Valve and Charge Pressure Relief Valve:

The shuttle and charge pressure valve work together to bypass closed loop oil. This allows the oil to be cooled, filtered, and returned to tank.

The circuit shows the shuttle valve and the charge pressure relief valve. Stroking the variable displacement pump creates system pressure on one side of the closed loop. This system pressure shifts the shuttle valve, opening the low pressure side of the loop to the second charge pressure relief valve. The charge pressure relief valve will now close as it has a higher valve setting. This closed valve will now cause total charge pump flow to enter the low pressure side through the lower check valve. The charge pump flow first replenishes the lubrication fluid lost from the closed loop. The remaining charge flow will then displace an equivalent volume of hotter fluid in the low pressure side. This displaced fluid passes through the shuttle valve and second charge pressure relief valve directly into the motor case, pump case, heat exchanger and back into the reservoir. By continuously replacing the hotter loop fluid with the cool fluid, the closed loop temperature is stabilized.

The shuttle valve flow is listed below in relationship to the charge pressure valve setting.

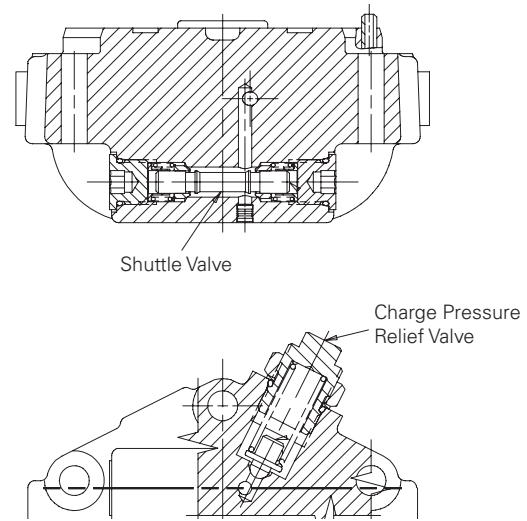

CHARGE PRESSURE	FLOW	CODE SELECTION
10 to 12 bar [145 to 175 lbf/in ²]	5.68 to 9.46 l/m [1.5 to 2.5 gal/min]	AM
15 to 17 bar [220 to 250 lbf/in ²]	9.46 to 13.25 l/m [2.5 to 3.5 gal/min]	AD

Note: All ports are SAE (J1926) O-ring ports.
Dimensions are in millimeters [inches], unless otherwise specified.
For other charge pressure options please contact Eaton representative

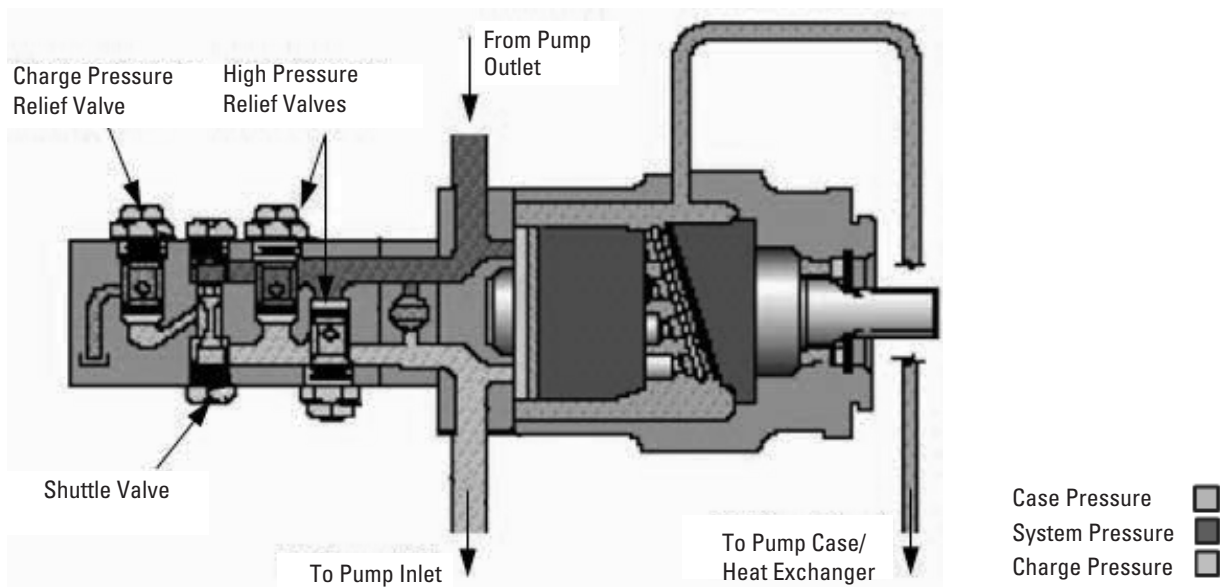

Model 743XX Fixed Displacement

Motor

Speed Sensor

(Code Position 10,11 selection AP)

Fixed motors are available with a speed sensor for measurement of motor output speed. This sensor will operate with a supply voltage of 4.5 to 15 Vdc, and requires a current of 12 mA at 5.0 Vdc (minimum) under no load. Refer following table for specifications: The sensor is available with a Packard Electrical Weather-Pack series.

The Hall Effect speed sensor is compatible with the mobile vehicle electrical systems and gives a reliable digital on/off signal over a wide speed and temperature range.

The rugged design is fully protected against reverse polarity or short circuit hook up. A built-in pull up resistor simplifies installation with control systems.

The motor speed sensor is a factory installed option.

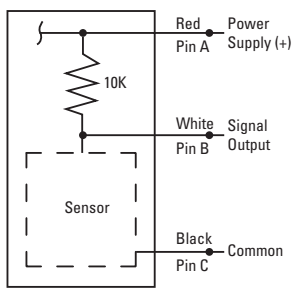

Output Circuit Wiring Instructions

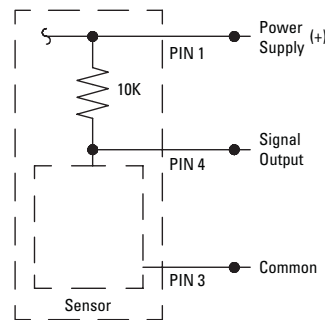
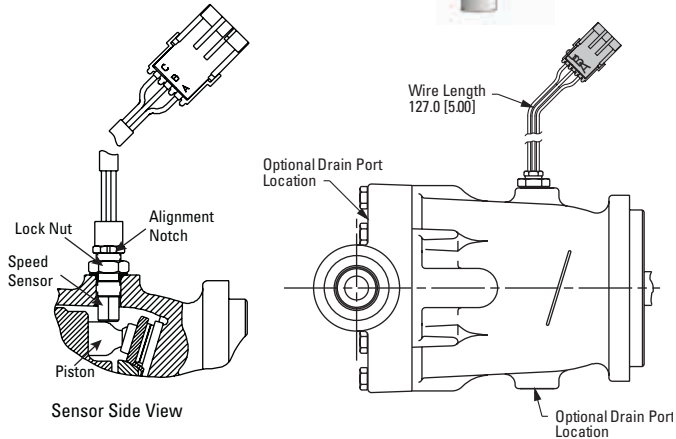
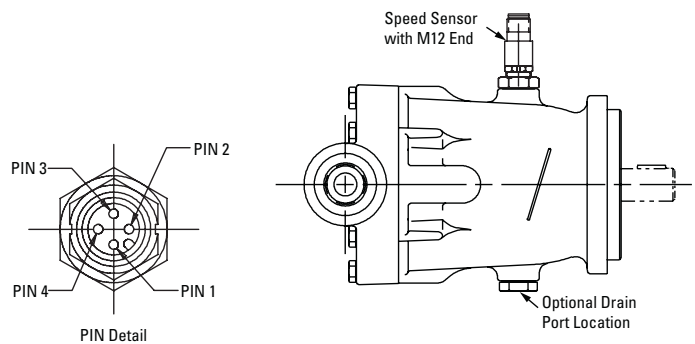
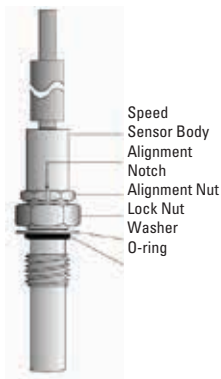

Output Circuit Wiring Instructions

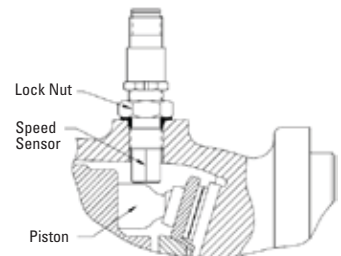

SPECIFICATION

Supply Voltage	(Vs) 8 to 28 Volt DC
Supply Current	(Is) 20 mA (including internal pull up resistor)
Switching Frequency	7 to 3K Hz
Output Voltage High	Supply Voltage minus 0.5 Volt DC min. (Open Collector with 10k Ω pull up resistor)
Output Voltage Low	(Vol) 0.5 Volt DC Maximum at 10 mA
Min. Shaft Speed	50 RPM
Pulses per Revolution	9

CONNECTION REQUIREMENTS

Cable	18 AWG Irradiated PVC-single conductor wires standard OR equivalent wall (Refer SAE J-1128 Type GXL) 1 black, 1 red, 1 white.
Packard Electric Weather Pack Series	Mating female connector assembly #12110293 and # 12048074 terminal (3X).

Speed Sensor - M12

Code position 10, 11 selection CA

Eaton has developed a speed sensor, based on the field proven technology of our Hall Effect and Magnetic sensor.

Output – Digital signals from NPN transistors (open collector output with internal 10K pull up resistors).

This sensor has reverse polarity protection, short circuit protection, load dump protection, and EMC (Electrical Magnetic Capability) protection (the customer should qualify the EMC protection in their specific application)

Supply Voltage: 8 to 24 Volt DC (compatible with 12V vehicle conditions)

SPECIFICATION

Supply Voltage	(Vs) 8 to 28 Volt DC
Supply Current	(Is) 20 mA (including internal pull up resistor)
Switching Frequency	7 to 3K Hz
Output Voltage High	Open Collector with 10k Ω pull up resistor
Output Voltage Low	(Vol) 0.5 Volt DC Maximum at 10 mA
Min. Shaft Speed	50 RPM
Pulses per Revolution	9

CONNECTION REQUIREMENTS

Mates with DC Micro connectors or equivalent:	Turk Eurofast WKCV 4T cable
	Brad Harrison Micro-Change single keyway plugs
	Lumberg Micro style 12mm DC connector

Model 746XX Fixed Displacement Motor

2 Bolt SAE B-B Mount

82.6 cm³/r [5.04 in³/r] Displacement

Single Motor - Product Number

7 4 6 2 4 - D A H
 A B C

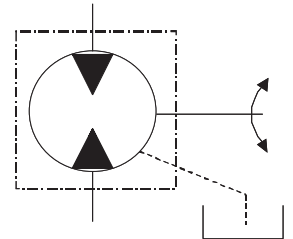

Identification numbers – Fixed Displacement Motor - Closed Circuit
 Stamped on each unit.

A – Product Number Description

74624 = 82.6 cm³/r [5.04 in³/r] (W/Bearing Upgrade)

74644 = 82.6 cm³/r [5.04 in³/r] Through Shaft for Brake Mount
 (W/Bearing Upgrade)

B – Rotation

D = Dual

C – Sequential Letter



Serial Number Code

10 05 06 XXX 1 000

Last Two Digits of Year Built. (10 for 2010 etc.) ————
 Month Built (two digits) ————
 Day Built (two digits) ————
 Specific Number of the Pump ————
 Shift Number ————
 Manufacturing Cell ————

TYPICAL PRODUCT NUMBER	MODEL CODE	SPECIFICATIONS	MODEL 74624/74644
74624-DAH	AAZAAAA0000A0B	Maximum Displacement	82.6 cm ³ /r [5.04 in ³ /r]
74624-DAV	AAZAABB0000A0B	Maximum Rated Speed	1500 RPM
74644-DAJ	AAZAABBA000A0B	Nominal Pressure Rating †	250 bar [3626 lbf/in ²]
74624-DAB	AAZADAA0000A0B	Peak Pressure Rating ††	265 bar [3900 lbf/in ²]
74644-DAJ	AAZAABBA000A0B	Input Flow at Rated Speed and Pressure	150.0 l/min [33 GPM]
		Output Power at Rated Speed and Pressure	52 kW [70 hp]
		Output Torque at Rated Speed and Pressure	329 N•m [2910 lbf•in]
		Continuous Allowable Case Pressure	7 bar [100 lbf/in ²]
		Continuous Inlet Temperature	107° C [225° F]
		Weight/Single Motor (approximate)	10.9 kg [24 lbs]

† Nominal Pressure: Max delta system pressure at which component fatigue does not occur (motor life estimated by bearing life).

†† Peak Pressure: Max operation pressure which is permissible for a short duration of time (t < 1 sec).

Model 74624 Fixed Displacement Motor

The dual piston design with combination of solid and hollow pistons which gives displacement of $82.6 \text{ cm}^3/\text{r}$, provides power dense package. Uses lightweight aluminum housing, end cover with rear & top side working ports. Numerous

output shafts with through drive capabilities for brake mounting. End cover houses main ports, gauge ports.

Attached cross section view shows major components of the motor.

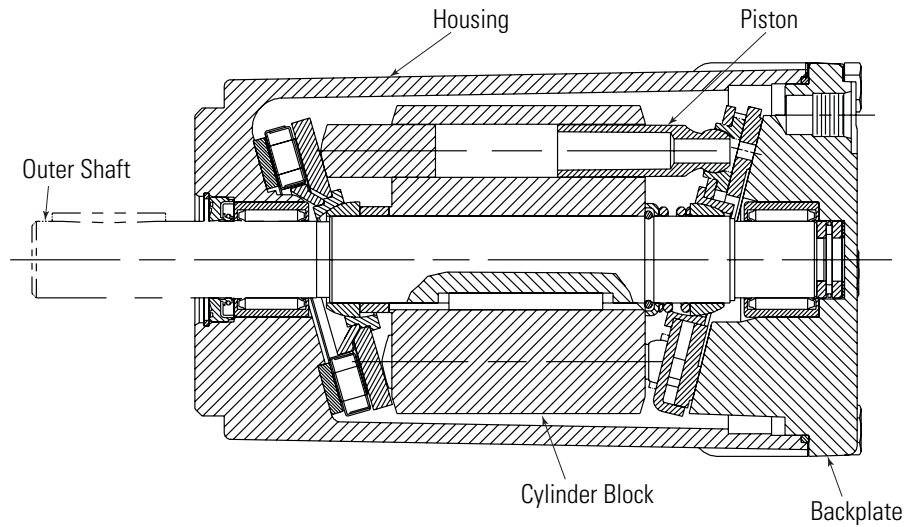

Model 746XX Fixed Displacement Motor

82.6 cm³/r [5.04 in³/r] Displacement

High torque fixed displacement piston motors are specified by the following model code. Once a motor is built from the model code, a product number will be assigned to that

configuration. Make sure all positions are selected within the 14 digit code for each motor.

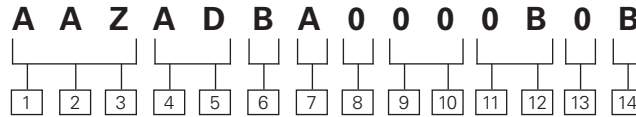

[1][2][3] Code Title

AAZ - 82.6 cm³/r [5.04 in³/r] High Torque Fixed displacement piston motor frame size

[4][5] Output Shaft

AA - Straight Shaft, dia. 25.4[1.00], keyway 6.35[.250] X 38.1[1.50], shaft extension 63.5 [2.50] (key included), (std.)
AD - 15 Tooth 16/32 spline with snap ring groove, shaft extension 46 [1.81], (std.)
AE - 13 Tooth 16/32 spline, shaft extension 41.1 [1.62], (std.)

[6] Main Port, Size, & Location

A - 1-1/16-12 UN-2B straight thread O-ring ports- rear, (std.)
B - 1-1/16 UN-2B straight thread O-ring ports same side, top, (opt.)

[7] Drain Port, Size, & Location

A - 9/16-18 UNF-2B straight thread O-ring port - Horizontal top rear of unit, (std.)
B - 9/16-18 UNF-2B Straight thread O-ring port – Vertical top rear of unit, (opt.)
D - Through drain into mounting flange (Front)

[8] Auxiliary Mounting Features (rear)

0 - No Auxiliary Mounting Feature - Model 74624, (std.)
A* - Straight through shaft, dia. 25.4 [1.00], with keyway 6.35 x 25.4 [.250 x 1.00], Shaft length from mounting flange 274.3 [10.80] (key included); 2 mounting holes 5/16- 18 UNC-2B Thd, 13.3 [.53] min. full thread (bottom rear of unit) - Model 74644, (opt.)
B - 15 Tooth 16/32 spline, with .375-16 UNC-2B thread, 18.3 [.72] min full thread, shaft length from mounting flange 274.3 [10.80]; 2 mounting holes .3125-18 UNC-2B thread, 13.3[.53] min full thread (Bottom rear of unit)

***Note:** Requires the selection of same side porting only. (opt.)

[9][10] Special Features

00 - No Special Features, (std.)

[11][12] Paint

0A - Primer, (std.)
0B - Black Paint, (std.)

[13] Identification

0 - Standard, (std.)

[14] Design Code

B - Bearing Upgrade

Note: All ports are SAE (J1926) O-ring ports.

Model 74624 and 74644 Fixed Displacement Motor

Output Shaft Options

(Code Position 4,5)

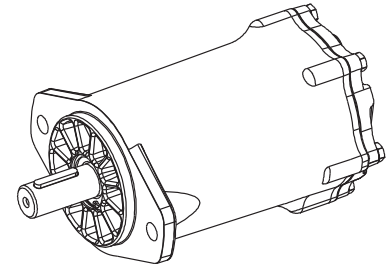

Used for all 746XX models

Straight Shaft

(Code selection AA)

Maximum Torque on Shaft.
337.5 N•m [2,987 lbf•in]

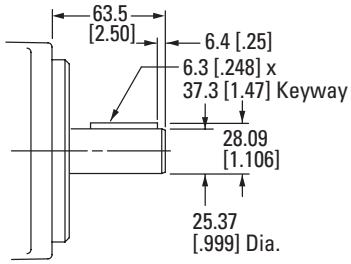

Spline Shaft

(Code selection AD)

Maximum Torque on Shaft.
337.5 N•m [2,987 lbf•in]

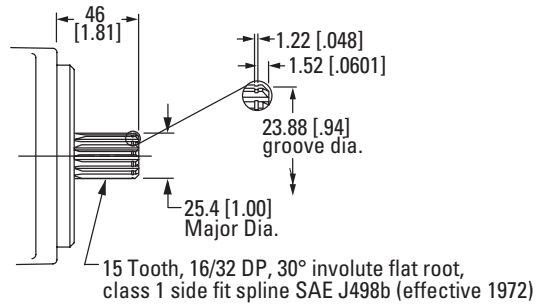

Spline Shaft

(Code selection AE)

Maximum Torque on Shaft.
209.3 N•m [1,852 lbf•in]

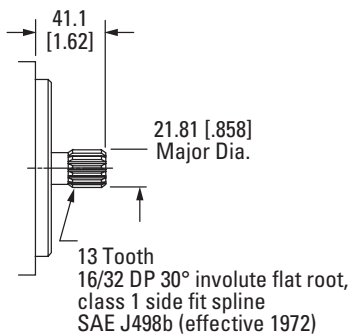

Model 74624 Fixed Displacement Motor

Installation Drawings

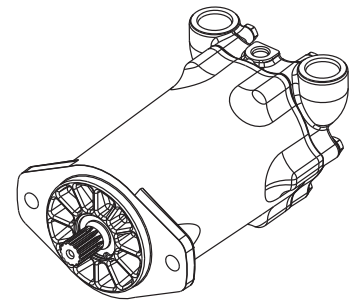

Rear Porting

(Code position 6, selection A)

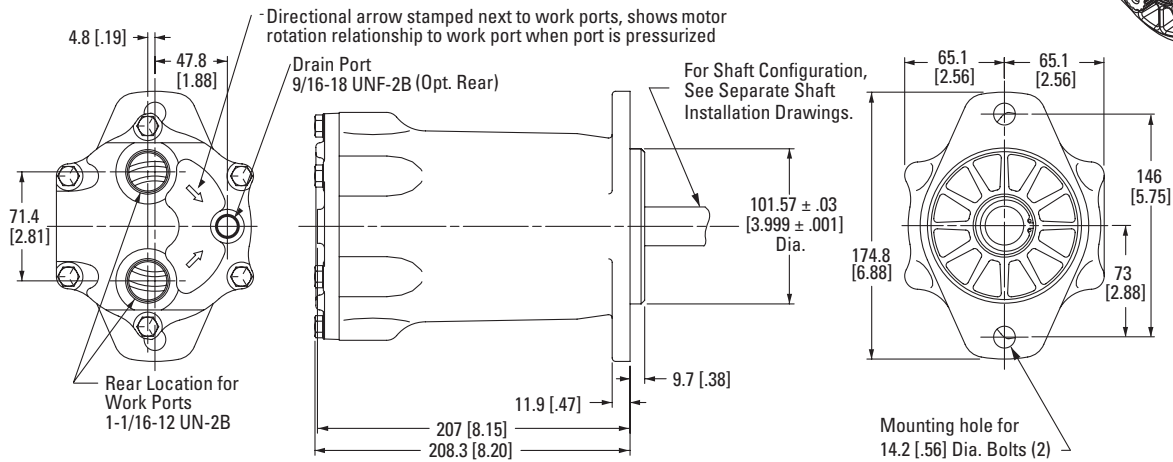

Same Side Porting

(Code position 6, selection B)

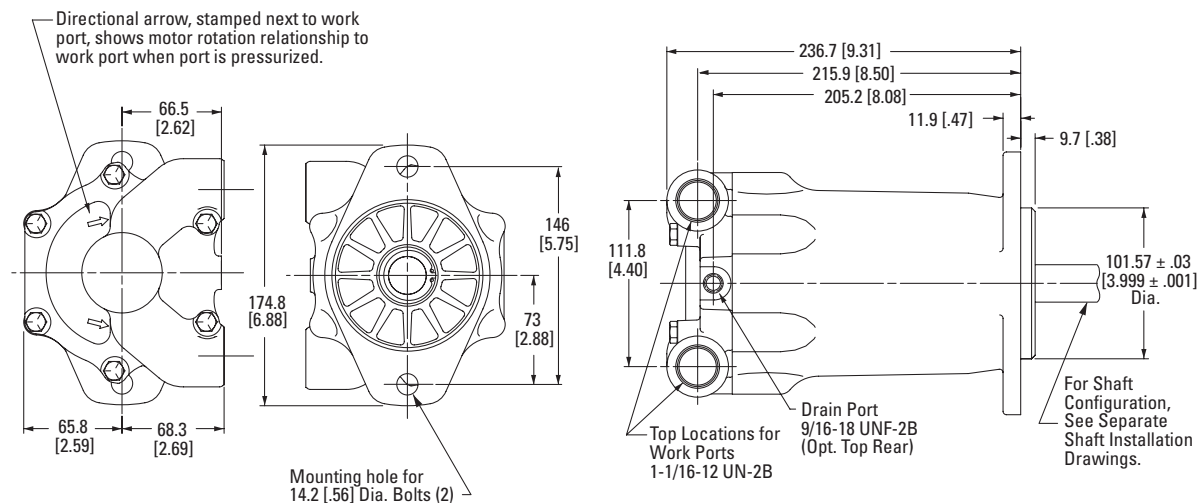

Through Shaft for Brake Mounting

(Code position 8, selection A or C)

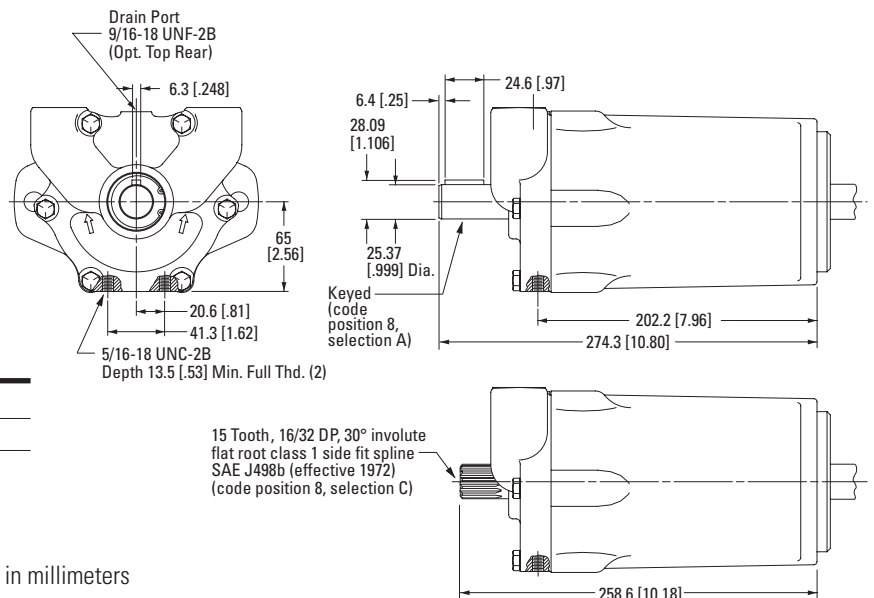

TYPE OF PORT	SIZE AND DESCRIPTION
Work Port	1- 1/16 - 12 UN-2B SAE O-ring
Drain Port	9/16 - 18 UN-2B SAE O-ring

Note: All ports are SAE (J1926) O-ring ports. Dimensions are in millimeters [inches], unless otherwise specified.

CENTRALA ELBLĄG

Ul. Rawska 19B
82-300 Elbląg

tel. /+48/ 55 625 51 00

fax /+48/ 55 625 51 01

Dział Handlowy

tel. /+48/ 55 625 51 51

elblag@hydropress.pl



www.hydropress.pl

ODDZIAŁ GDAŃSK

tel. /+48/ 55 625 51 21

fax /+48/ 55 625 51 22

ODDZIAŁ RUMIA

tel. /+48/ 58 679 34 15

fax /+48/ 55 625 51 25

ODDZIAŁ TYCHY

tel. /+48/ 32 787 52 88

fax /+48/ 55 625 51 38

ODDZIAŁ OLSZTYN

tel. /+48/ 89 532 01 05

fax /+48/ 89 715 21 42

ODDZIAŁ WARSZAWA

tel. /+48/ 22 468 86 97

fax /+48/ 55 625 51 32

BIURO WE WROCŁAWIU

tel. /+48/ 782 838 000

fax /+48/ 55 625 51 35

BIURO W KIELCACH

tel. /+48/ 885 995 501

fax /+48/ 55 625 51 01

BIURO W KRAKOWIE

tel. /+48/ 885 995 019

fax /+48/ 55 625 51 01

BIURO W OPOLU

tel. /+48/ 885 995 011

fax /+48/ 55 625 51 01

BIURO W BYDGOSZCZY

tel. /+48/ 790 222 771

fax /+48/ 55 625 51 01

BIURO W BIAŁYMSTOKU

tel. /+48/ 89 532 01 05

fax /+48/ 89 715 21 42

BIURO W ŁODZI

tel. /+48/ 609 221 421

fax /+48/ 89 715 21 42