



POMPY ŁOPATKOWE O ZMIENNEJ WYDAJNOŚCI SERIA VVS/VVP

Contents

Introduction	Page 3
Sectional Views and Functional Symbols	Page 4
Series VVS Pumps	
Model Code.....	Page 5
Technical Data.....	Page 6
Performance Characteristics	
VVS0.....	Page 7
VVS1.....	Page 8
VVS2.....	Page 9
VVS3.....	Page 10
Installation Dimensions	
VVS0.....	Page 11
VVS1.....	Page 12
VVS2 & VVS3.....	Page 13
Series VVP Pumps	
Model Code.....	Page 15
Technical Data.....	Page 16
Controls	
Pressure Regulation.....	Page 17
Load Sensing and Pressure Regulation.....	Page 18
Pressure Regulation with Torque Sensing.....	Page 20
Performance Characteristics	
VVP1.....	Page 21
VVP2.....	Page 22
VVP3.....	Page 23
Installation Dimensions	
VVP1.....	Page 24
VVP2 & VVP3.....	Page 25
Series VVS and VVP Pumps	
Installation Dimensions - Base Mounted Pumps.....	Page 27
Combined Pumps	
Pump Combinations.....	Page 28
Torque Requirements.....	Page 30
Installation Dimensions.....	Page 31
Key Lock Adjustment	Page 35
Mounting, Shaft and Port Dimensions	Page 36
Installation Instructions	Page 37

Introduction

Description

Maximum displacements to 100 cm³/r (6.1 in³/r).

Maximum pressures to 160 bar (2300 psi).

Vickers variable displacement vane pumps are available in four nominal sizes (0-1-2-3) and are divided into three displacements. Each size, while retaining the same pump body, is available in two versions: low pressure VVS (100 bar, 1500 psi) with mechanical pressure regulator, and high pressure VVP (160 bar, 2300 psi) with hydraulic pressure regulator. The rotor shaft of Vickers pumps is pre-arranged for mounting an additional pump. By removing the rear cover, the secondary pump can be easily attached (see items A and B on page 4). Combining standard pumps eliminates the need for many "special application" pumps.

As shown in the cross-sectional views, pumps consist of:

- (1) Body
- (2) One-piece shaft and rotor
- (3) Vanes
- (4) Pressure ring that changes the eccentricity and therefore the displacement of the pump, at hydrostatic axial compensation
- (5) Pressure plate stator to provide the passage of oil from the suction port to the pressure port
- (6) Guide block balancing adjustment screw
- (7) Displacement adjustment piston that regulates the maximum pressure compensated flow
- (8) Maximum volume adjustment screw (optional feature - see model code pages 5 and 15).
- (9) Pressure regulator
- (10) Pressure regulator adjustment

Features and Benefits

- Long pump life resulting from manufacturing material characteristics, hydrodynamic lubrication of bearings, and hydrostatic balancing of distribution plates.
- Quiet pump operation from 55 to 73 dB(A).
- Simplifies hydraulic circuit by eliminating maximum pressure relief valves and heat exchangers. Pumps can be supplied with various pressure regulators to control the maximum system pressure.
- Standard ISO and SAE mountings.
- Combinations of standard pumps provide flexibility and cost effective pump packages.

Modular Construction

VVS mechanical pressure compensator

VVP hydraulic pressure compensator for pressure and flow controls

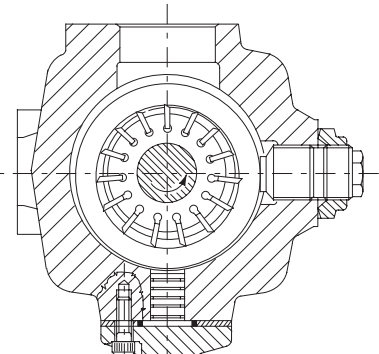
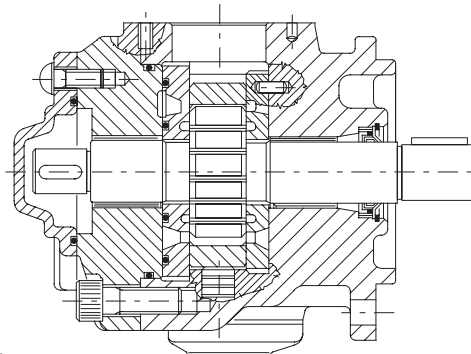
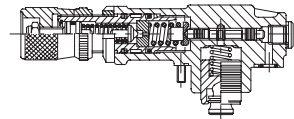
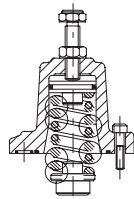

Basic pump

Sections and Symbols

VVP Pump

See description on page 3.

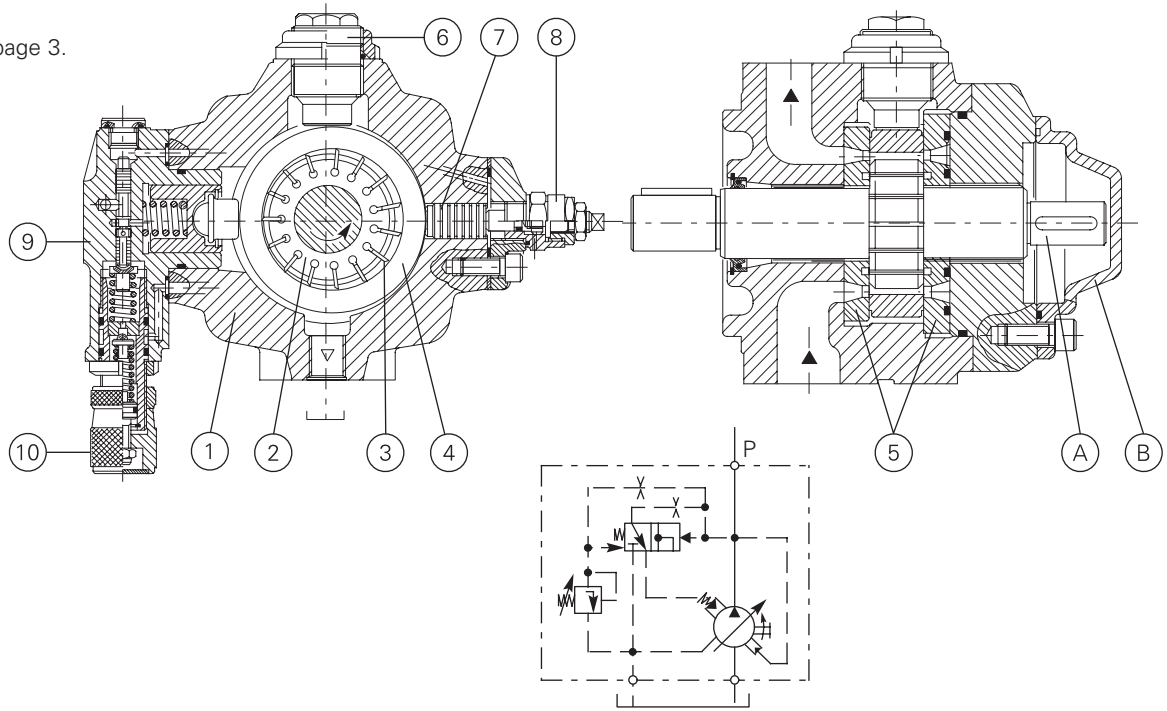

VVS Pump

See description on page 3.

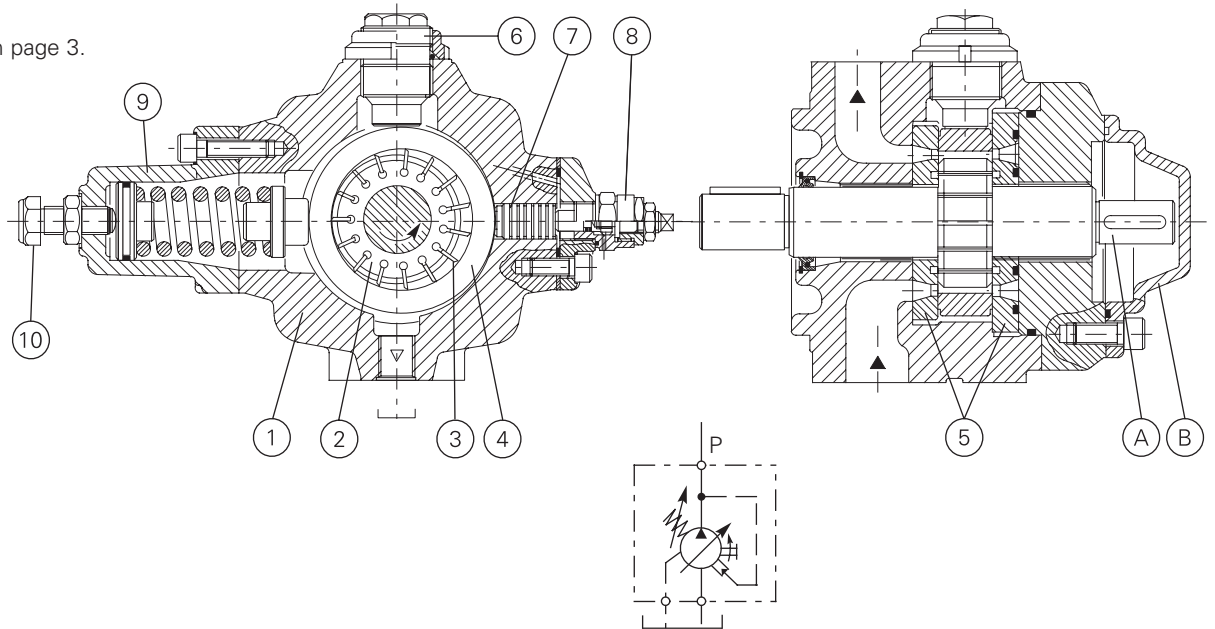

Model Code

VVS Series

VVS 1 - 16 - (S) R R M - *0 - C - D W - 10 - **

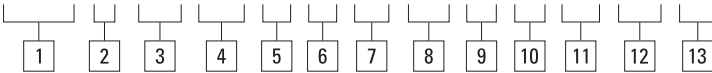

1 Variable Vane Pump

2 Frame Size / Max. Pressure

0	-	6.3, 10, 12.5 cm ³ /r Max. pressure 150 bar (2200 psi)
1	-	16, 20, 25 cm ³ /r Max. pressure 100 bar (1500 psi)
2	-	31.5, 40, 50 cm ³ /r Max. pressure 100 bar (1500 psi)
3	-	63, 80, 100 cm ³ /r Max. pressure 80 bar (1200 psi)

3 Nominal Size / Geometric Displacement

06	-	6.3 cm ³ /r (0.38 in ³ /r)
10	-	10 cm ³ /r (0.61 in ³ /r)
12	-	12.5 cm ³ /r (0.76 in ³ /r)
16	-	16 cm ³ /r (0.98 in ³ /r)
20	-	20 cm ³ /r (1.22 in ³ /r)
25	-	25 cm ³ /r (1.53 in ³ /r)
32	-	31.5 cm ³ /r (1.92 in ³ /r)
40	-	40 cm ³ /r (2.44 in ³ /r)
50	-	50 cm ³ /r (3.05 in ³ /r)
63	-	63 cm ³ /r (3.84 in ³ /r)
80	-	80 cm ³ /r (4.88 in ³ /r)
100	-	100 cm ³ /r (6.10 in ³ /r)

4 Adjust. Max. Displacement Stop

S - With stop
(Omit if not required.)

5 Mounting Flange / Port Connections

Code	Frame Size	Mounting flange	Port connections
R	Size 0 or 1	ISO 3019/2 with straight keyed shaft (size 0 is only available as a single or secondary pump)	G (BSPF) thread.
RF	Size 2 or 3	ISO 3019/2 with straight keyed shaft	SAE 4-bolt flange with metric mounting bolts
PS	Size 0	ISO 3019/2 with straight keyed shaft (for size 0 pumps only). Size 0 is only available as a single or secondary pump.	SAE UNF thread.
	Size 1	SAE B 4-bolt with straight keyed shaft (for size 1 pumps only)	
PF	Size 2 or 3	SAE C 2-bolt with straight keyed shaft (only available on a primary or single pump)	SAE 4-bolt flange with UNC mounting bolts
PX	Size 2 or 3	ISO 3019/2 with straight keyed shaft (available only on secondary pump)	SAE 4-bolt flange with UNC mounting bolts
B	Sizes 1, 2 or 3	Base plate mounting (available only as single pump)	O-ring sealed

Note: See page 36 for detailed dimensional listing for mounting flanges, shafts and ports.

6 Rotation Viewed From Shaft End

R - Right hand (clockwise) only

7 Fluid Compatibility

M - Mineral oil
E - Phosphate esters

8 Pump Design Number

30 - All models except
Subject to change. Installation dimensions remain unaltered for designs *0-*9.

9 Pressure Control

C - Standard pressure compensator

10 Control Pressure Setting

A - 15-50 bar (215-700 psi) (all frame sizes)
B - 30-80 bar (430-1200 psi) (frame size 3)
C - 30-100 bar (430-1500 psi) (frame sizes 0, 1 and 2)
D - 80-150 bar (1200-2200 psi) (frame size 0)

11 Adjustment Device

W - Screw with locknut
KL - Screw with key lock

12 Control Design Number

10 - For all models.
Subject to change. Installation dimensions remain unaltered for designs 10-19.

13 Special Features Suffix

Technical Data

VVS Series

Nominal size	Size 0	Size 1	Size 2	Size 3
Displacement according to ISO 3662 - cm ³ /r (in ³ /r)	6.3 (0.384)	16 (0.976)	31.5 (1.922)	63 (3.844)
	10 (0.610)	20 (1.220)	40 (2.441)	80 (4.882)
	12.5 (0.763)	25 (1.526)	50 (3.051)	100 (6.102)
Actual displacement - cm ³ /r (in ³ /r)	6.9 (0.421)	17.9 (1.092)	34.5 (2.105)	69 (4.211)
	11 (0.671)	22.1 (1.349)	42.8 (2.612)	86.2 (5.260)
	13.1 (0.799)	26.9 (1.642)	53.1 (3.240)	105.5 (6.438)
Mounting flange type (See model code, page 5.)	ISO 3019/2	ISO 3019/2	ISO 3019/2	ISO 3019/2
	4-bolt	4-bolt Base plate	SAE C 2-bolt Base plate	SAE C 2-bolt Base plate
Maximum working pressure - bar (psi)	150 (2200)	100 (1500)	100 (1500)	80 (1200)
Allowed maximum drain port pressure - bar (psi)	1 (14.5)			
Inlet pressure (absolute) - bar (psi)	0.8-1.5[11.6-21.8]			
Speed range - r/min	800 to 1800			
Rotation direction (viewed from shaft end)	Right-hand (clockwise)			
Loads on drive shaft	No radial or axial loads allowed			
Maximum torque on primary shaft - Nm (lbf-in) (See pages 28 and 30 for torque requirements of combined pumps.)	110 (974)	197 (1744)	400 (3540)	740 (6550)
Hydraulic fluid	Mineral oil - HM according to ISO 6743/4 - HLP according to DIN 51524/2 Organic ester HFD-V according to ISO 6743/4 (QUINTOLUT-SRIC N822-300)			
Viscosity range at working temperature - mm ² /s (cSt)	23 to 68			
Recommended viscosity - mm ² /s (cSt) at 50°C (122°F)	32			
Viscosity index	100 minimum			
Fluid temperature range - °C (°F)	-10/+50 [14/122]			
Maximum fluid contamination level	Class 9 per NAS 1638, or class 18/16/13 per ISO 4406			
Weight - kg (lb)	6.5 (14.3)	12 (26.5)	32 (70.5)	44 (97)

In case of different operating conditions, contact Eaton Hydraulics.

Performance Characteristics

VVS0

Performance with:

Speed 1450 r/min
 Oil per ISO 6743/4
 Viscosity 32 mm²/s (cSt)
 Temperature 50°C (122°F)

Power consumption with maximum flow

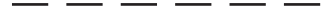

Power consumption with zero flow setting



VVS0-06

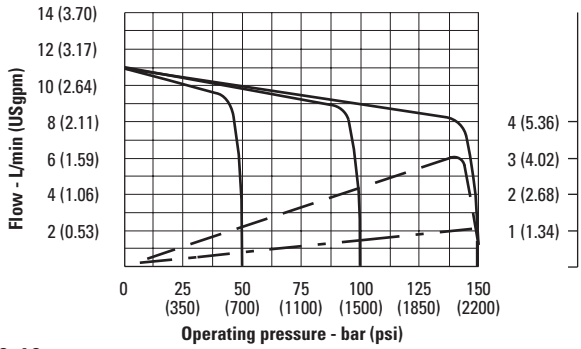

VVS0-06, -10, -12

Values established with zero flow setting

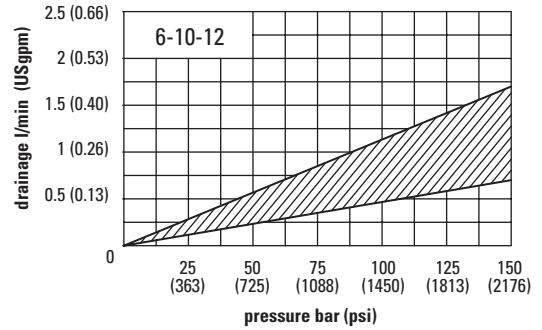

VVS0-10

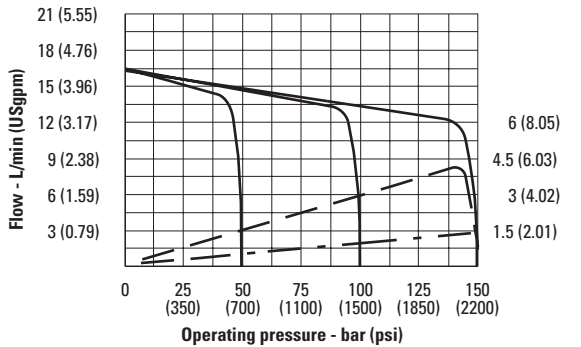

VVS0-06, -10, -12

Maximum noise level measured with sound-level meter placed at 1 meter [39.37"] from pump, flexible coupling.

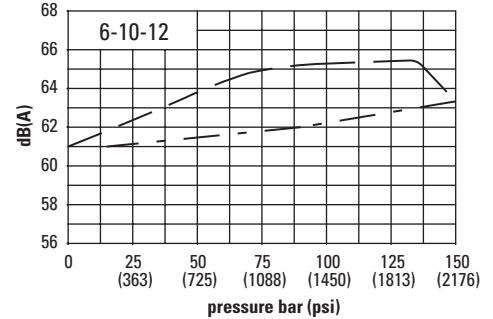

VVS0-12

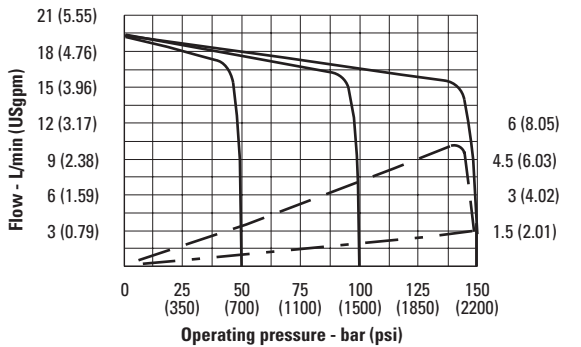

VVS0-06, -10, -12

Response time and pressure peak

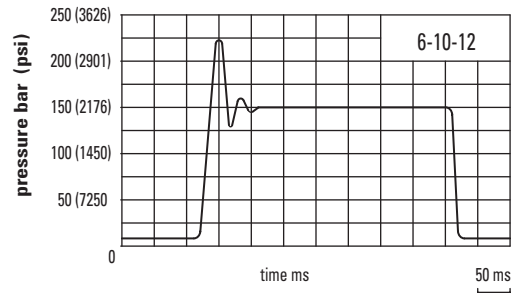

Performance Characteristics

VVS1

Performance with:

Speed 1450 r/min
 Oil per ISO 6743/4
 Viscosity 32 mm²/s (cSt)
 Temperature 50°C (122°F)

Power consumption with maximum flow



Power consumption with zero flow setting



VVS1-16

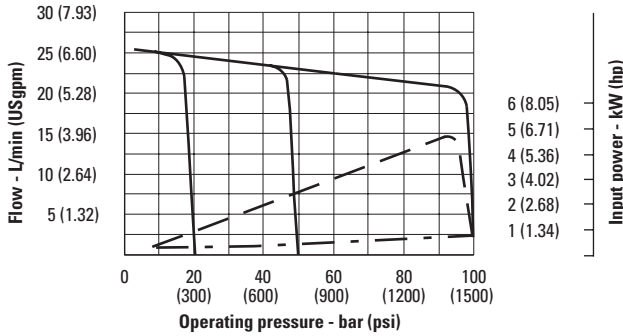

VVS1-16, -20, -25

Values established with zero flow setting

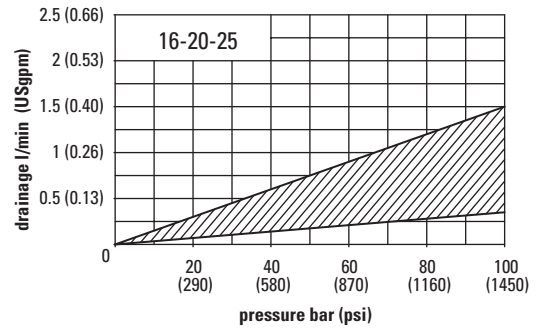

VVS1-20

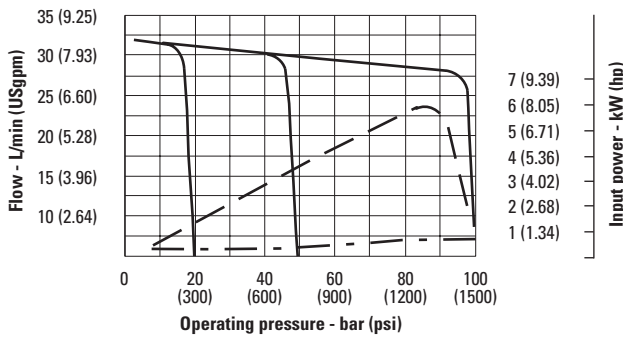

VVS1-16, -20, -25

Maximum noise level measured with sound-level meter placed at 1 meter [39.37"] from pump, flexible coupling.

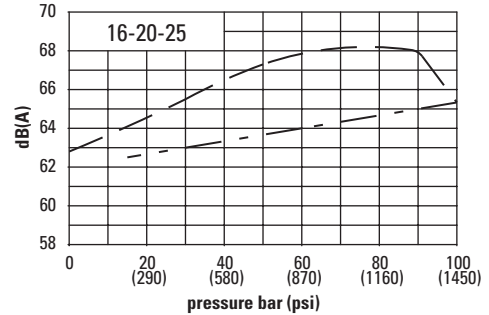

VVS1-25

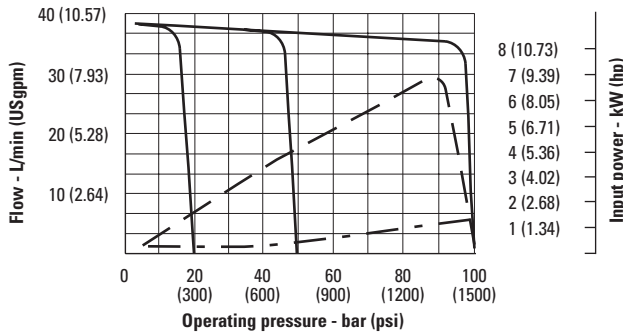

VVS1-16, -20, -25

Response time and pressure peak

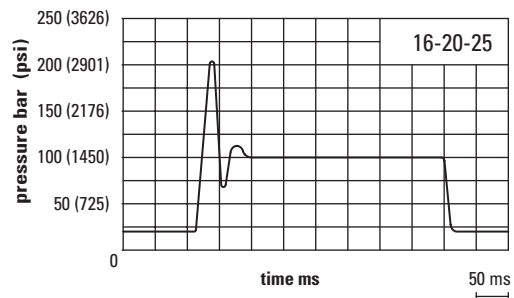

Performance Characteristics

VVS2

Performance with:

Speed 1450 r/min
 Oil per ISO 6743/4
 Viscosity 32 mm²/s (cSt)
 Temperature 50°C (122°F)

Power consumption with maximum flow



Power consumption with zero flow setting



VVS2-32

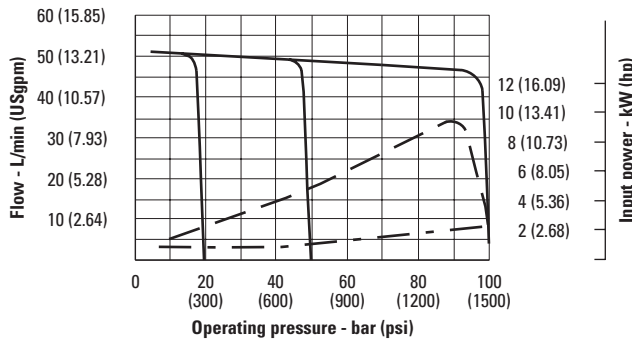

VVS2-32, -40, -50

Values established with zero flow setting

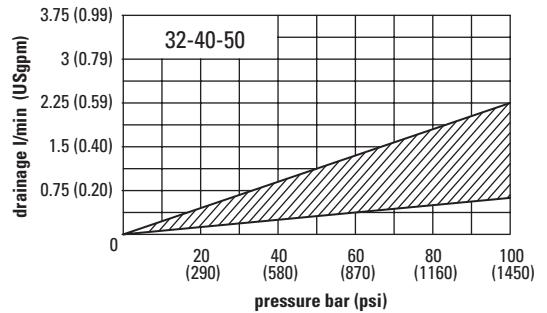

VVS2-40

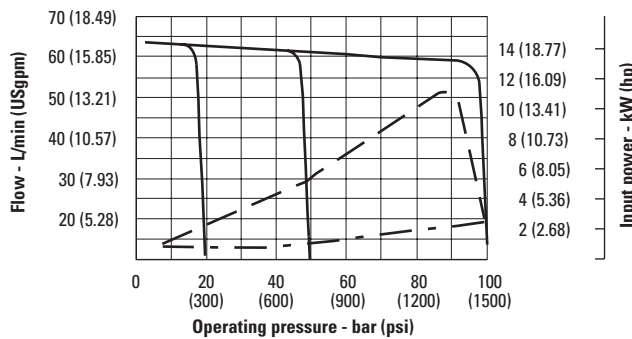

VVS2-32, -40, -50

Maximum noise level measured with sound-level meter placed at 1 meter [39.37"] from pump, flexible coupling.

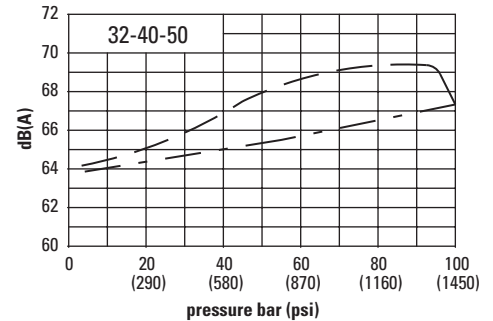

VVS2-50

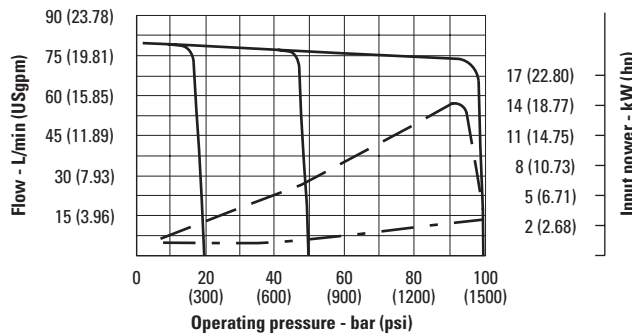

VVS2-32, -40, -50

Response time and pressure peak

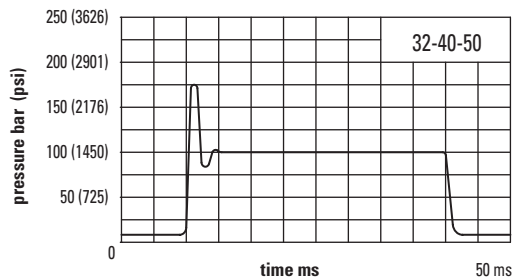

Performance Characteristics

VVS3

Performance with:

Speed 1450 r/min
 Oil per ISO 6743/4
 Viscosity 32 mm²/s (cSt)
 Temperature 50°C (122°F)

Power consumption with maximum flow



Power consumption with zero flow setting



VVS3-63

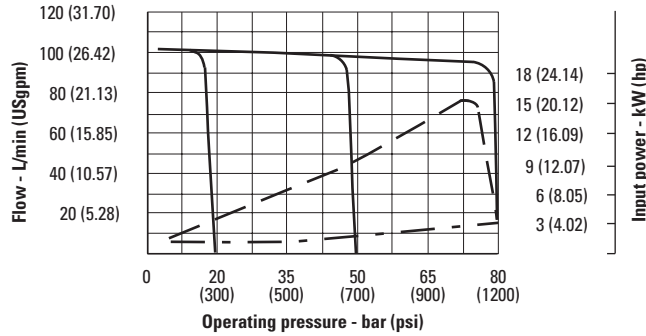

VVS3-63, -80, -100

Values established with zero flow setting

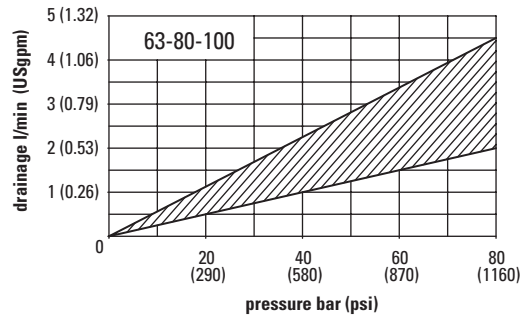

VVS3-80

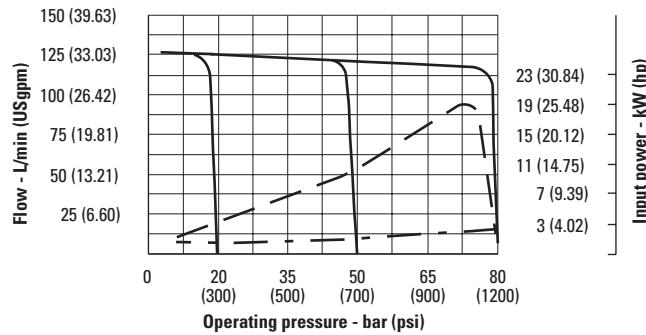

VVS3-63, -80, -100

Maximum noise level measured with sound-level meter placed at 1 meter [39.37"] from pump, flexible coupling.

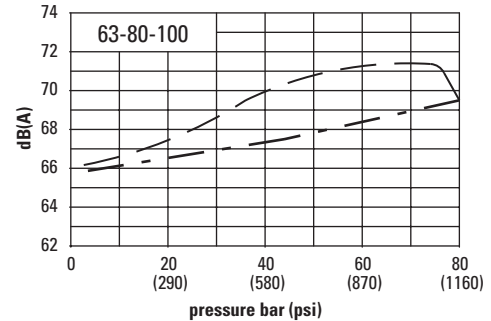

VVS3-100

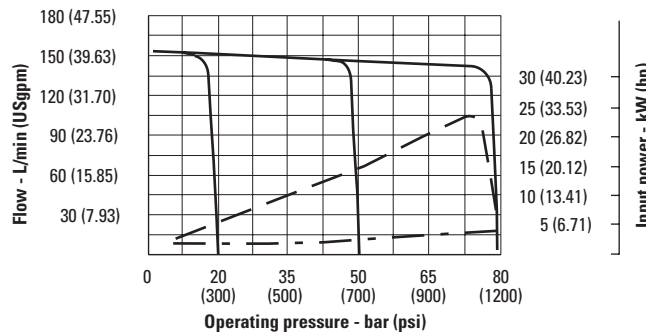

VVS3-63, -80, -100

Response time and pressure peak

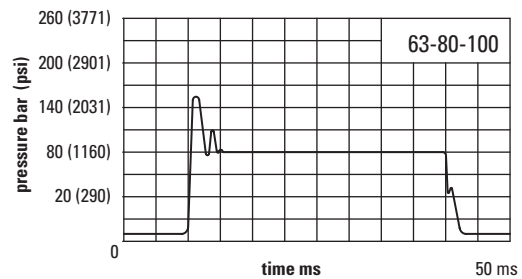

VVS0

With ISO Mounting Flange

Installation Dimensions
in mm (in)

All mounting flange, port and shaft options are listed on page 36.



"C" Control With "W" Adjustment

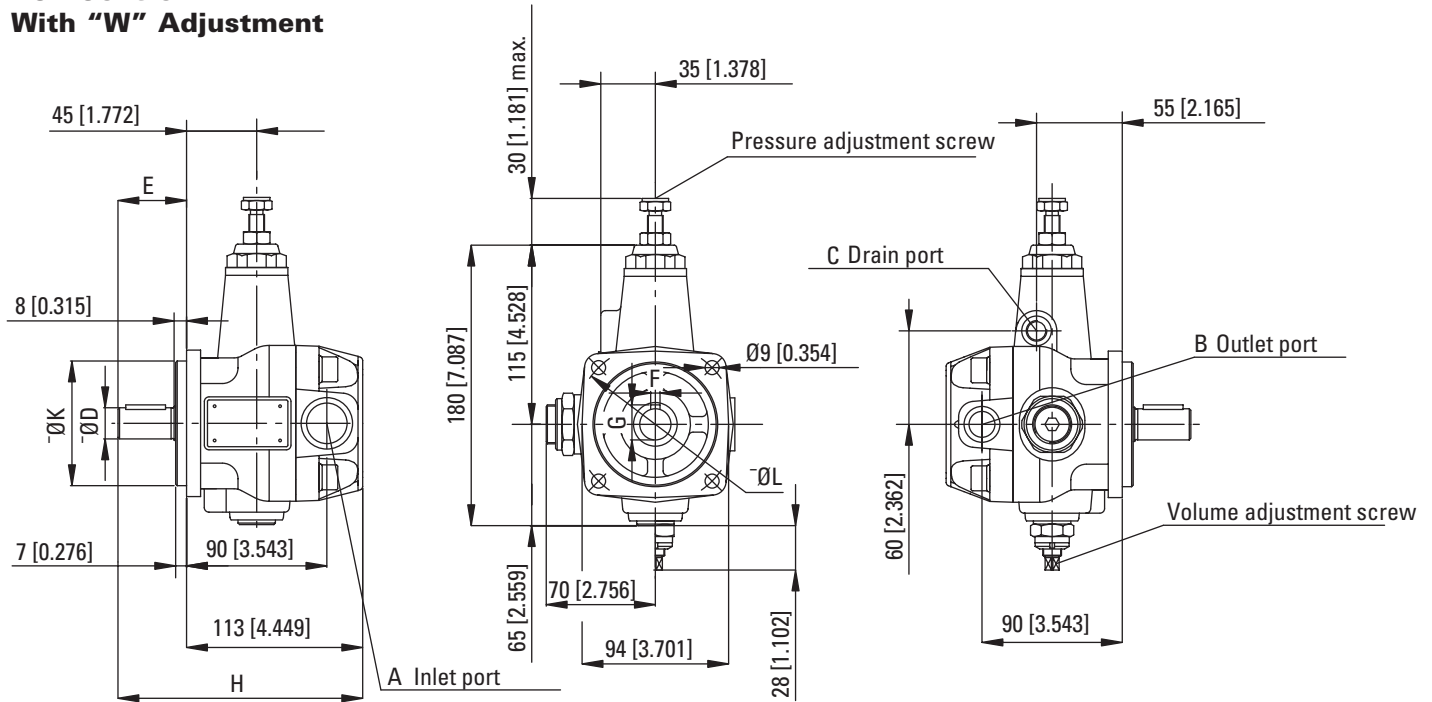

"C" Control With "KL" Adjustment

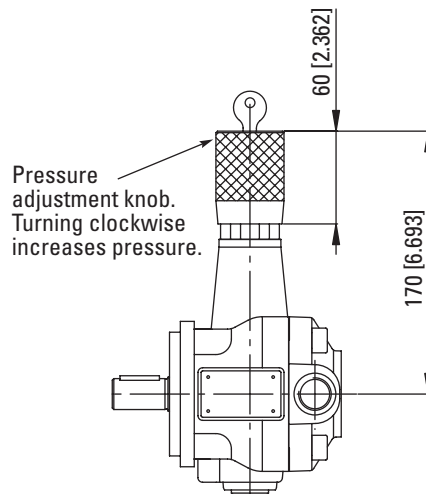

MOUNTING FLANGE AND PORTS CODE▲	B	C	F	G	Ø D	A	H	E	Ø K	Ø L
R	3/8" BSP	1/4" BSP	6 (0.236)	22.5 (0.886)	20 (0.787)	3/4" BSP	157 (6.18)	44 (1.73)	80 (3.150)	103 (4.055)
PS	0.750-16 UNF-2B	0.500-20 UNF-2B	4.76 (0.187)	17.9 (0.705)	15.88 (0.625)	1.063-12 UNF-2B	136 (5.35)	32 (1.25)	80 (3.150)	103 (4.055)

▲ See model code, page 5.

VVS1

With ISO or SAE Mounting Flange

Installation Dimensions
in mm (in)

All mounting flange, port and shaft options are listed on page 36.



"C" Control With "W" Adjustment

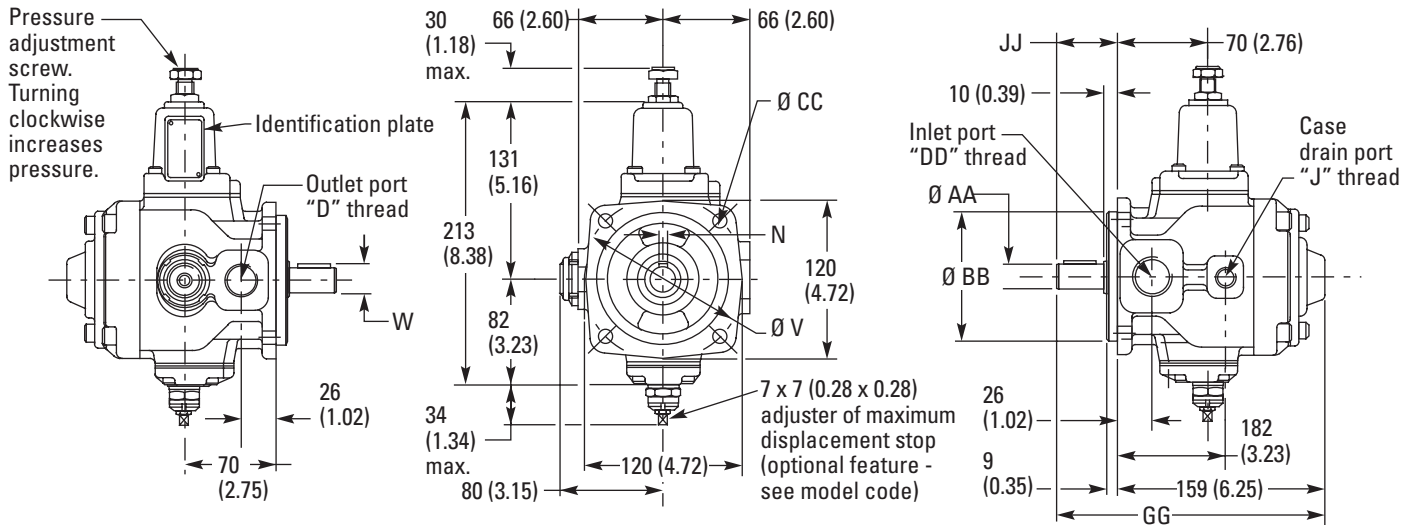

"C" Control With "KL" Adjustment

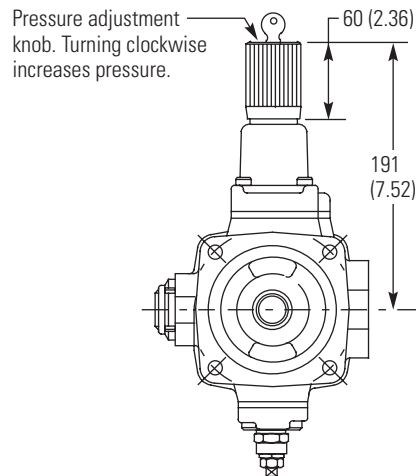

MOUNTING FLANGE AND PORTS CODE ▲

	D	J	N	Ø V	W	AA	Ø BB	Ø CC	DD	GG	JJ
R (ISO)	3/4" BSP	3/8" BSP	8 (0.315)	125 (4.921)	28 (1.102)	25 (0.984)	100 (3.937)	11 (0.43)	1" BSP	205 (8.07)	46 (1.81)
PS (SAE)	1.0625-12 UNF-2B	0.5625-18 UNF-2B	6.35 (0.250)	127 (5.000)	28.17 (1.109)	25.4 (1.000)	101.6 (4.000)	14.3 (0.56)	1.3125-12 UNF-2B	207 (8.15)	48 (1.89)

▲ See model code, page 5.

VVS2 and VVS3

With ISO Mounting Flange

Installation Dimensions
in mm (in)

All mounting flange, port and shaft options are listed on page 36.



"C" Control With "W" Adjustment

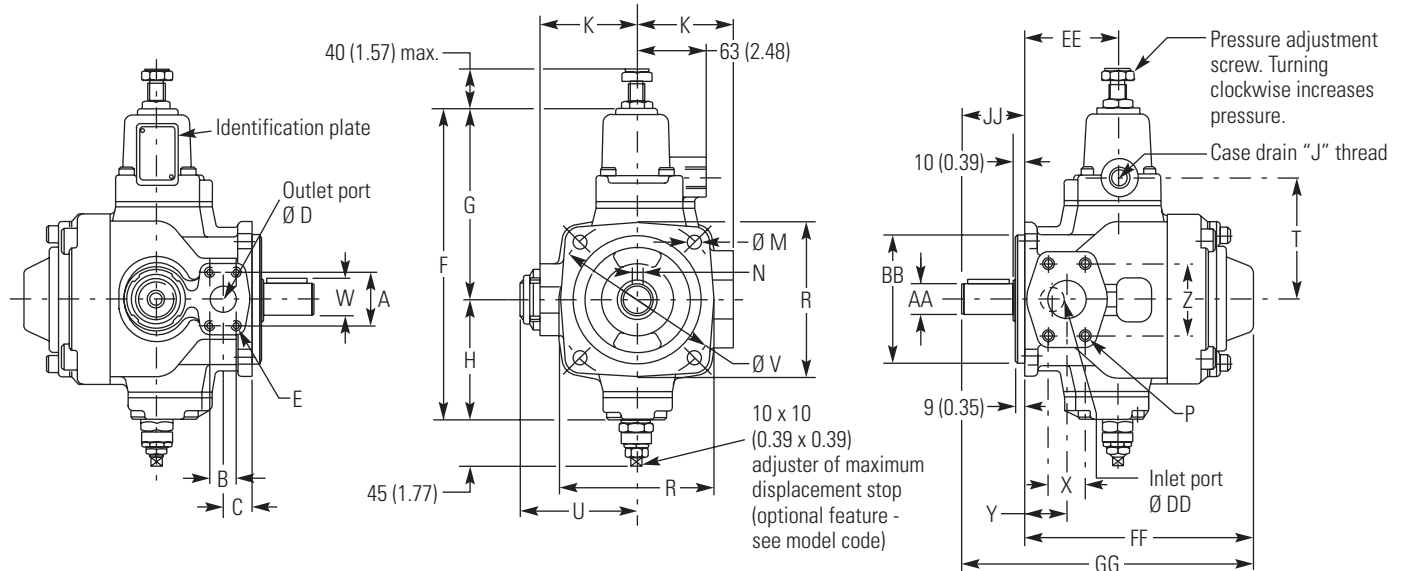

"C" Control With "KL" Adjustment

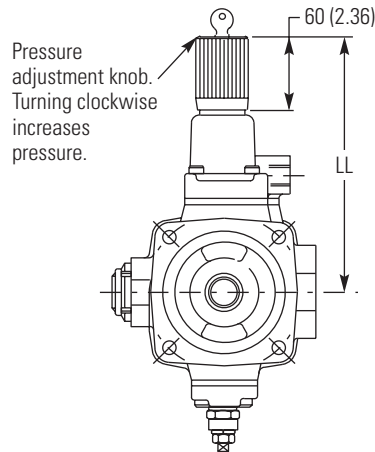

MODEL	A	B	C	Ø D	E	F	G	H	J	K	Ø M	N	P	R
VVS2	52.4 (2.06)	26.2 (1.03)	30 (1.18)	25 (0.98)	M10 or 0.375-16 UNC-2B ▲	285 (11.22)	175 (6.89)	110 (4.33)	1/2" BSP or 0.875-14 UNF-2B ▲	95 (3.74)	14 (0.55)	10 (0.39)	M12 or 0.500-13 UNC-2B ▲	150 (5.91)
VVS3	58.7 (2.31)	30.2 (1.19)	35 (1.378)	32 (1.26)	M10 or 0.4375-14 UNC-2B ▲	305 (12.01)	185 (7.28)	120 (4.72)	1/2" BSP or 0.875-14 UNF-2B ▲	105 (4.13)	18 (0.71)	12 (0.47)	M12 or 0.500-13 UNC-2B ▲	185 (7.28)

▲ See mounting flange/port connections codes RF and PX, page 5.

MODEL	T	U	Ø V	W	X	Y	Z	Ø AA	Ø BB	Ø DD	EE	FF	GG	JJ	LL
VVS2	115 (4.53)	114 (4.488)	160 (6.30)	35 (1.38)	35.7 (1.41)	40 (1.58)	70 (2.76)	32 (1.26)	125 (4.92)	38 (1.50)	91 (3.58)	219 (8.62)	279 (10.98)	60 (2.36)	235 (9.25)
VVS3	125 (4.92)	123 (4.84)	200 (7.87)	43 (1.69)	43 (1.69)	46 (1.81)	77.8 (3.06)	40 (1.57)	160 (6.30)	51 (2.01)	105 (4.13)	245 (9.65)	313 (12.32)	68 (2.68)	245 (9.65)

VVS2 and VVS3

With SAE Mounting Flange

Installation Dimensions
in mm (in)

All mounting flange, port and shaft options are listed on page 36.



"C" Control With "W" Adjustment

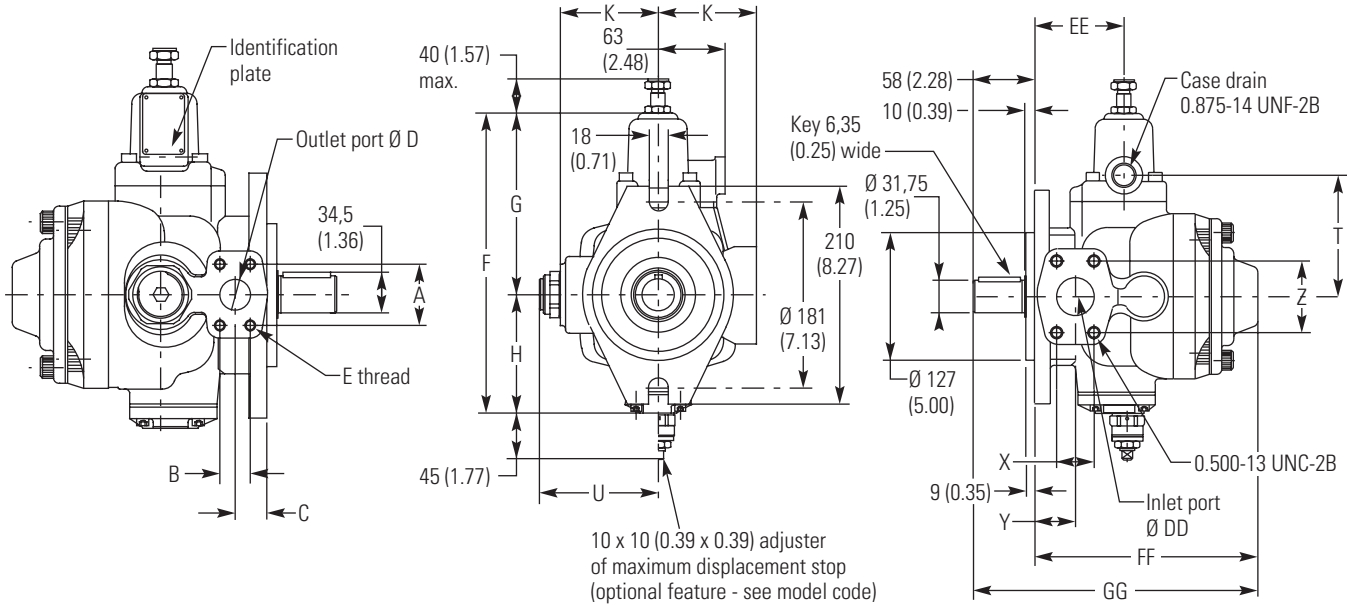

"C" Control With "KL" Adjustment

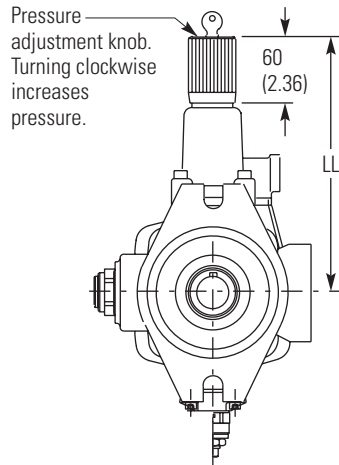

MODEL	A	B	C	$\varnothing D$	E	F	G	H	K	T
VVS2	52.4 (2.06)	26.2 (1.03)	27 (1.06)	25 (0.98)	0.375-16 UNC-2B	285 (11.22)	175 (6.89)	110 (4.33)	95 (3.74)	115 (4.53)
VVS3	58.7 (2.31)	30.2 (1.19)	35 (1.38)	32 (1.26)	0.4375-14 UNC-2B	305 (12.01)	185 (7.28)	120 (4.72)	105 (4.13)	125 (4.92)

MODEL	U	X	Y	Z	$\varnothing DD$	EE	FF	GG	LL
VVS2	114 (4.49)	35.7 (1.41)	40 (1.58)	70 (2.76)	38 (1.50)	91 (3.58)	219 (8.622)	279 (10.984)	235 (9.25)
VVS3	123 (4.84)	43 (1.69)	46 (1.81)	77.8 (3.06)	51 (2.01)	105 (4.13)	245 (9.65)	303 (11.93)	245 (9.65)

Model Code VVP Series

VVP 1 - 20 - (S) R R - M - 30 - CVTCE (03) - B * - 04 - 15 - 10 - **

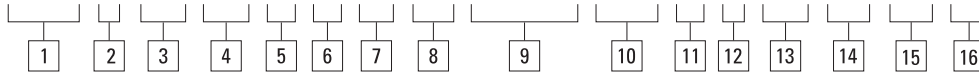

1 Variable Vane Pump

2 Frame Size / Max. Pressure

- 1 - 16, 20, 25 cm³/r
Max. pressure 160 bar (2300 psi)
- 2 - 31.5, 40, 50 cm³/r
Max. pressure 160 bar (2300 psi)
- 3 - 63, 80, 100 cm³/r
Max. pressure 150 bar (2200 psi)

3 Nominal Size / Geometric Displacement

- 16 - 16 cm³/r (0.98 in³/r)
- 20 - 20 cm³/r (1.22 in³/r)
- 25 - 25 cm³/r (1.53 in³/r)
- 32 - 31.5 cm³/r (1.92 in³/r)
- 40 - 40 cm³/r (2.44 in³/r)
- 50 - 50 cm³/r (3.05 in³/r)
- 63 - 63 cm³/r (3.84 in³/r)
- 80 - 80 cm³/r (4.88 in³/r)
- 100 - 100 cm³/r (6.10 in³/r)

4 Adjust. Max. Displacement Stop

- S - With stop
(Omit if not required.)

5 Mounting Flange / Port Connections

Code	Frame Size	Mounting flange	Port connections
R	Size 1	ISO 3019/2 with straight	G (BSPF) thread keyed shaft
RF	Size 2 or 3	ISO 3019/2 with straight keyed shaft	SAE 4-bolt flange with metric mounting bolts
PS	Size 1	SAE B 4-bolt with straight keyed shaft	SAE UNF thread
PF	Size 2 or 3	SAE C 2-bolt with straight keyed shaft (only available on a primary or single pump)	SAE 4-bolt flange with UNC mounting bolts
PX	Size 2 or 3	ISO 3019/2 with straight keyed shaft (available only on secondary pump)	SAE 4-bolt flange with UNC mounting bolts
B	All	Base plate mounting (available only as single pump)	O-ring sealed

Note: See page 36 for detailed dimensional listing for mounting flanges, shafts and ports.

6 Rotation Viewed From Shaft End

- R - Right hand (clockwise) only

7 Seal Type

- M - Buna N
- E - Viton

8 Pump Design Number

- 30 - All models

Subject to change. Installation dimensions remain unaltered for designs 30-39.

9 Pump Controls

- C - Standard pressure compensator
- CR - Remote controlled pressure control
- CD1 - Dual pressure control with non-adjustable min. pressure
- CD2 - Dual adjustable pressure control
- CE - Proportional pressure control
- CVP - Load sensing compensator
- CVPR - Remote controlled load sensing control
- CVPD1 - Load sensing control with dual pressure with fixed minimum pressure
- CVPD2 - Load sensing control with dual adjustable pressure control
- CVPCE - Load sensing control with proportional pressure control
- CVT - Torque limiter
- CVTR - Remote controlled torque limiter
- CVTD - Torque control with dual adjustable pressure control
- CVTCE - Torque control with proportional pressure control

10 Electrical Rating And Wiring Connection

For CD*, CVPD*, CVTD pump controls, five options below apply; for CE, CVPCE, CVTCE, only option 03 applies.

- 00 - No control valve fitted
- 01 - 220V AC 50 Hz with DIN 43650 plug connection
- 02 - 115V AC 60 Hz with 1/2" NPT conduit box
- 03 - 24V DC with DIN 43650 plug connection
- 04 - 115V AC 60 Hz with DIN 43650 plug connection

(Omit if not required.)

11 Control Pressure Setting

- B - 30-160 bar (430-2300 psi) (frame sizes 1 and 2)
- C - 30-150 bar (430-2200 psi) (frame size 3)

12 Adjustment Device

Omit for CR, CE, CVPR, CVTD, CVPCE and CVTCE pump controls.

- K - Micrometer knob (standard)
- KL - Micrometer knob with key lock

13 Maximum Power Setting In kW

- Applies to CVT pump control only.
- ** - Factory setting of power limit in kilowatt; for example 04 = 4 kW

14 Maximum Pressure Setting

- Applies to CVT pump control only.
- ** - Factory setting of pressure for zero flow in 10 bar increments; for example 15 = 150 bar

15 Control Design Number

- 10 - For all models. Subject to change. Installation dimensions remain unaltered for designs 10-19.

16 Special Features Suffix

Technical Data

VVP Series

Nominal size	Size 1	Size 2	Size 3
Displacement according to ISO 3662 - cm ³ /r (in ³ /r)	16 (0.976)	31.5 (1.922)	63 (3.844)
	20 (1.220)	40 (2.441)	80 (4.882)
	25 (1.526)	50 (3.051)	100 (6.102)
Actual displacement - cm ³ /r (in ³ /r)	17.9 (1.092)	34.5 (2.105)	69 (4.211)
	22.1 (1.349)	42.8 (2.612)	86.2 (5.260)
	26.9 (1.642)	53.1 (3.240)	105.5 (6.438)
Mounting flange type (See model code, page 15.)	ISO 3019/2	ISO 3019/2	ISO 3019/2
	SAE 4-bolt	SAE C 2-bolt	SAE C 2-bolt
	Base plate	Base plate	Base plate
Maximum working pressure - bar (psi)	160 (2300)	160 (2300)	150 (2200)
Allowed maximum drain port pressure - bar (psi)	1 (15)		
Inlet pressure (absolute) - bar (psi)	0.8 to 1.5 [11.6 to 21.8]		
Speed range - r/min	800 to 1800		
Rotation direction (viewed from shaft end)	Right-hand (clockwise)		
Loads on drive shaft	No radial or axial loads allowed		
Maximum torque on primary shaft - Nm (lbf-in)	197 (1744)	400 (3540)	740 (6550)
(See pages 28 and 30 for torque requirements of combined pumps.)			
Hydraulic fluid	Mineral oil - HM according to ISO 6743/4 - HLP according to DIN 51524/2 Organic ester HFD-U according to ISO 6743/4 (QUINTOLUBRIC N-822-300)		
Viscosity range at working pressure - mm ² /s (cSt)	22 to 68		
Recommended viscosity - mm ² /s (cSt) at 50°C (122°F)	32		
Viscosity index	100 minimum		
Fluid temperature range - °C (°F)	-10/+50 [14/122]		
Maximum fluid contamination level	Class 9 per NAS 1638, or class 18/15 per ISO 4406		
Weight - kg (lb)	13 (28.7)	33 (72.8)	45 (99.2)

In case of different operating conditions, contact Eaton Hydraulics.

Controls for VVP Pumps

VVP pumps offer a wide selection of electrohydraulic controls for the regulation of pressure and volume.

In addition to the various pressure regulating controls, a hydraulic load-sensing control is available to provide pumps with maximum flexibility for use in energy saving systems.

The load sensing compensator control receives a signal pressure directly after an external throttle and before an actuator. When a variation in pressure is sensed (with a fixed fall in pressure $\Delta p = 20$ bar (300 psi), the control will automatically change the pump's displacement independent of pressure variations that occur in the circuit.

The load sensing control produces a notable reduction in displaced power and is recommended for use in applications where there are notable variations in torque (or force) and speed.

Pressure Regulation

Pump With Standard Pressure Compensator Model Code "C"

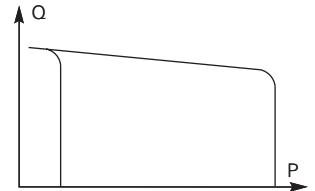
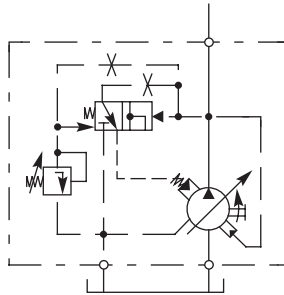

Pump With Remote Pressure Control Model Code "CR"

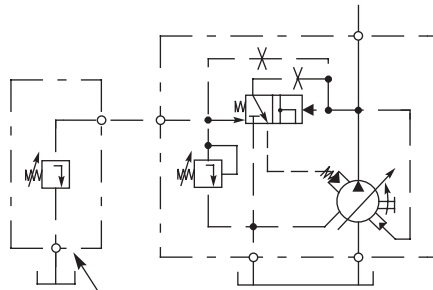

Remote max. pressure relief valve from 0 to 5 L/min (0 to 1.3 USgpm) not supplied.
Length of pilot line between compensator and relief valve should not exceed 5m (16 ft).

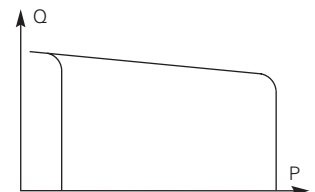

Pump With Two Stages of Pressure of Which One With Fixed Setting (At Minimum Pressure Level of Pump) Model Code "CD1"

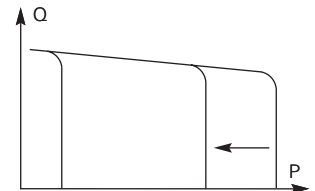
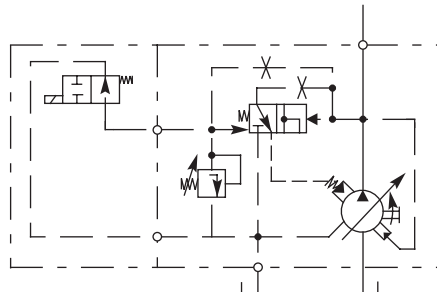

Controls for VVP Pumps (continued)

Pump With Two Adjustable Stages of Pressure
Model Code "CD2"

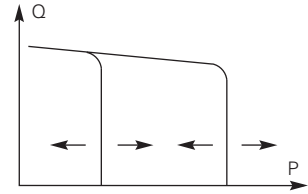
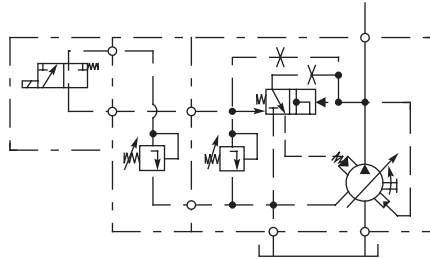

Pump With Proportional Pressure Control
Model Code "CE"

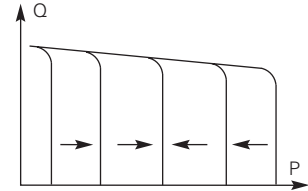
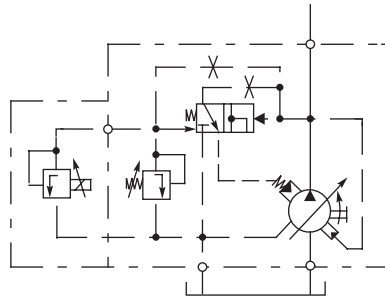

Load Sensing and Pressure Regulation

Load Sensing Pump for Standard Flow Control
Model Code "CVP"

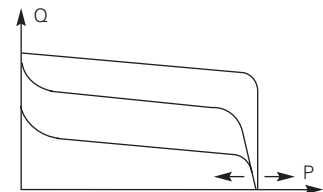
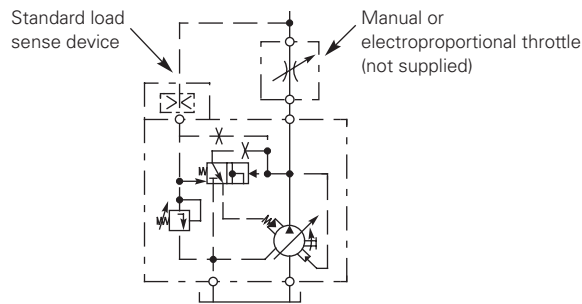

Load Sensing Pump With Remote Pressure Control
Model Code "CVPR"

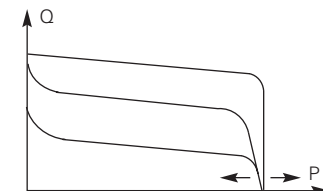
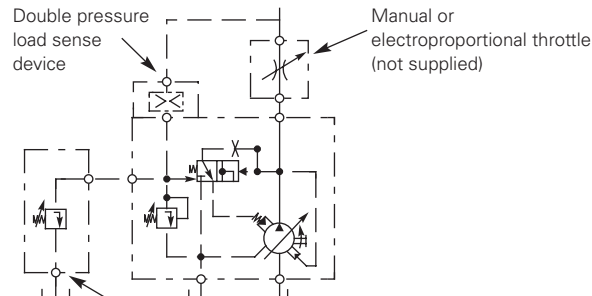

Max. pressure relief valve from 0 to 5 L/min (0 to 1.3 USgpm) not supplied.
Length of pilot line between compensator and relief valve should not exceed 5m (16 ft).

Controls for VVP Pumps (continued)

**Load Sensing Pump With Two Stages of Pressure of Which One With Fixed Setting (At Min. Pressure Level of Pump)
Model Code "CVPD1"**

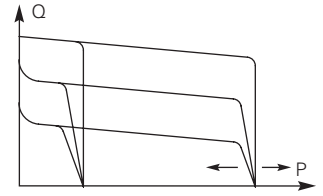
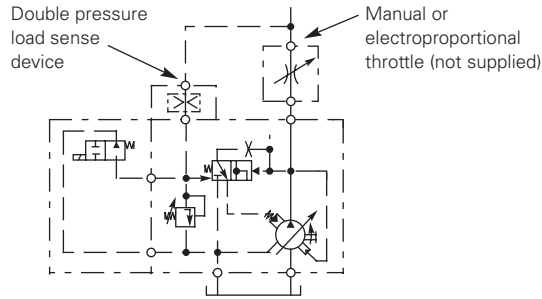

**Load Sensing Pump With Two Adjustable Stages of Pressure
Model Code "CVPD2"**

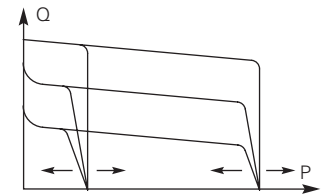
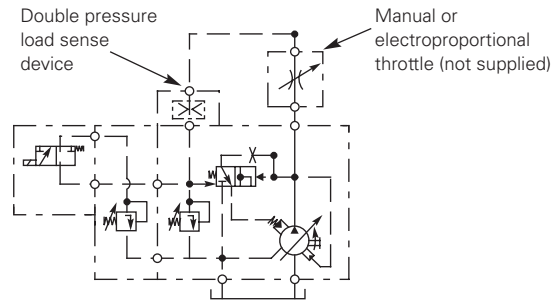

**Load Sensing Pump With Proportional Pressure Control
Model Code "CVPCE"**

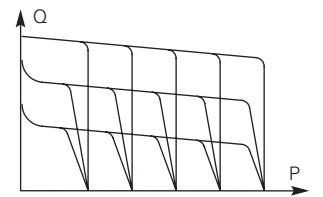
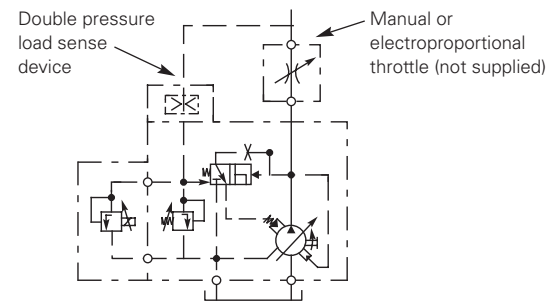

Pressure Regulation with Torque Sensing

**Torque Limiter
Model Code "CVT"**

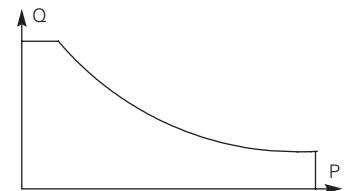
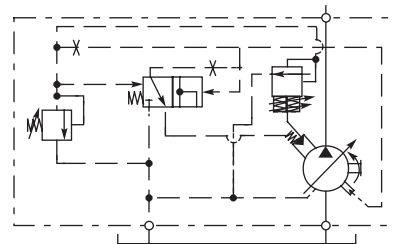

Controls for VVP Pumps (continued)

Remote Controlled Torque Limiter Model Code "CVTR"

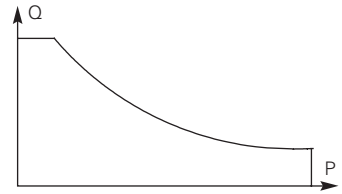
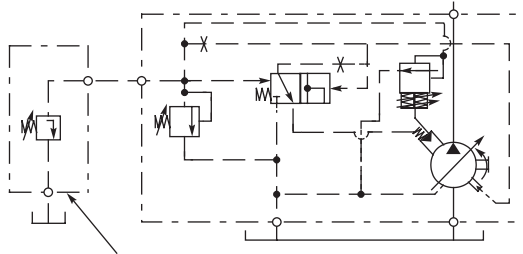

Remote max. pressure relief valve from 0 to 5 L/min (0 to 1.3 USgpm) not supplied. Length of pilot line between compensator and relief valve should not exceed 5m (16 ft).

Torque Control With Dual Pressure Control Model Code "CVTD" (Fixed Minimum Pressure)

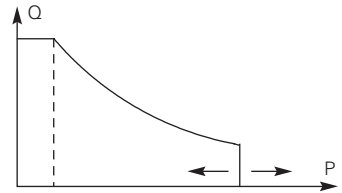
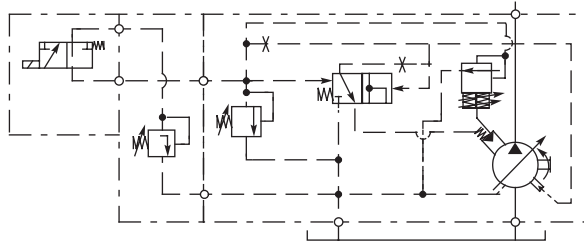

Torque Control With Proportional Pressure Control Model Code "CVTCE"

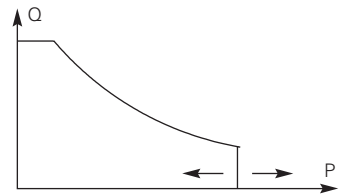
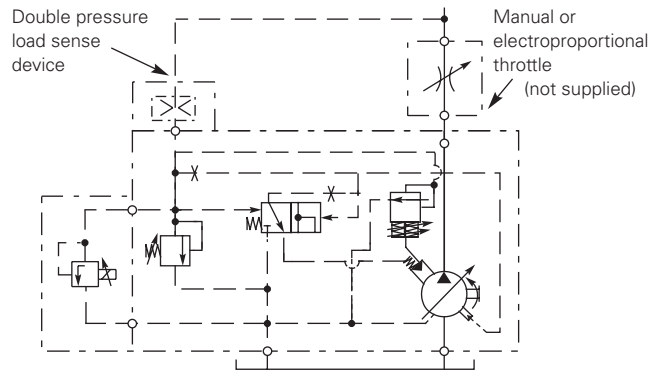

Performance Characteristics

VVP1

Performance with:

Speed 1450 r/min
 Oil per ISO 6743/4
 Viscosity 32 mm²/s (cSt)
 Temperature 50°C (122°F)

Power consumption with maximum flow



Power consumption with zero flow setting



VVP1-16

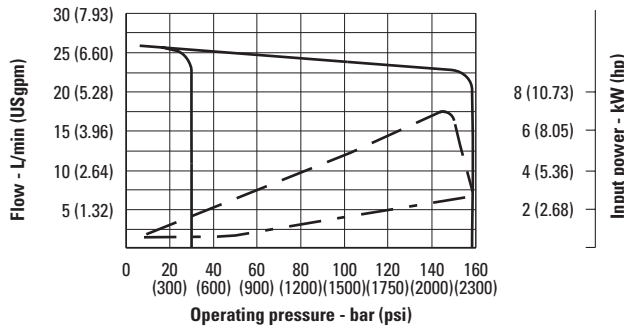

VVP1-16, -20, -25

Values established with zero flow setting

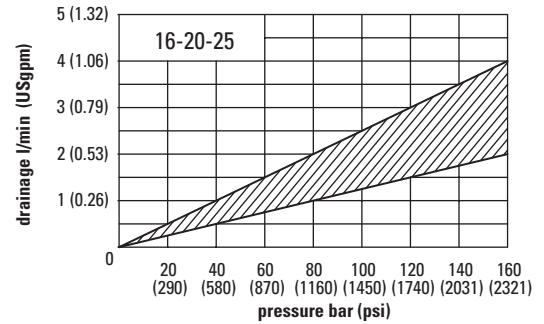

VVP1-20

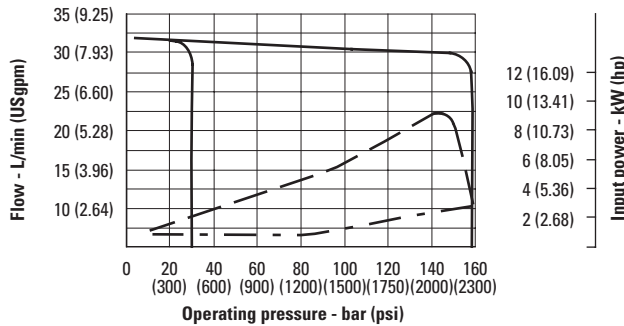

VVP1-16, -20, -25

Maximum noise level measured with sound-level meter placed at 1 meter [39.37"] from pump, flexible coupling.

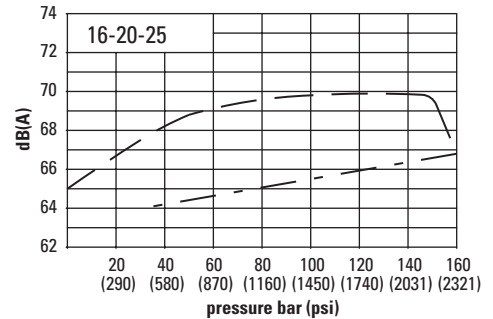

VVP1-25

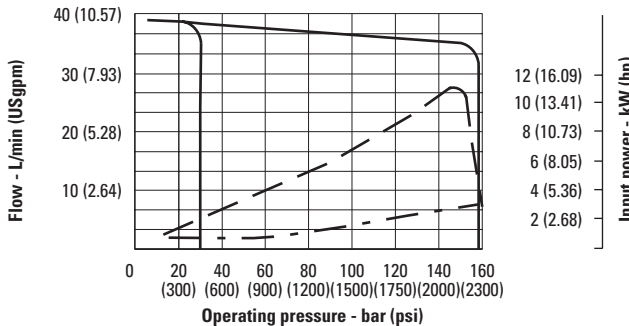

VVP1-16, -20, -25

Response time and pressure peak

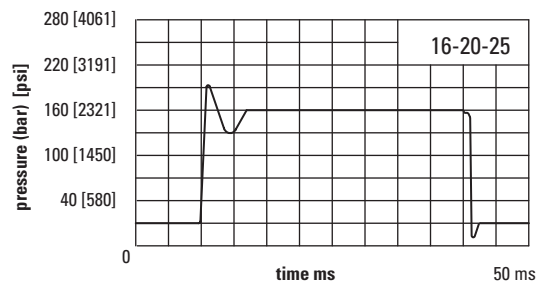

Performance Characteristics

VVP2

Performance with:

Speed 1450 r/min
 Oil per ISO 6743/4
 Viscosity 32 mm²/s (cSt)
 Temperature 50°C (122°F)

Power consumption with maximum flow



Power consumption with zero flow setting



VVP2-32

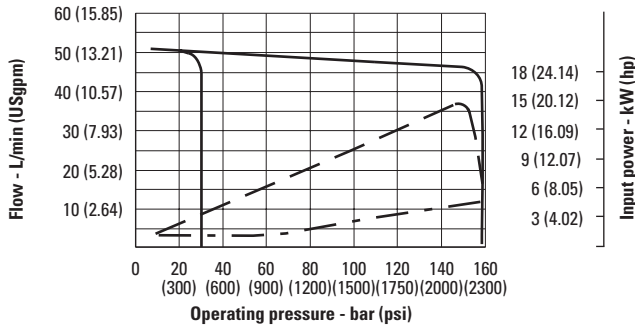

VVP2-32, -40, -50

Values established with zero flow setting

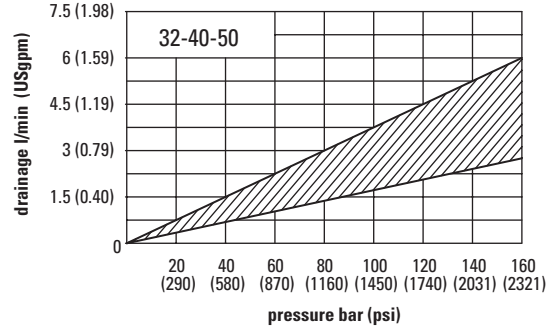

VVP2-40

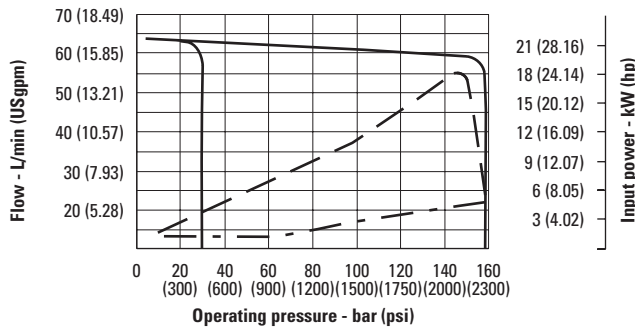

VVP2-32, -40, -50

Maximum noise level measured with sound-level meter placed at 1 meter [39.37"] from pump, flexible coupling.

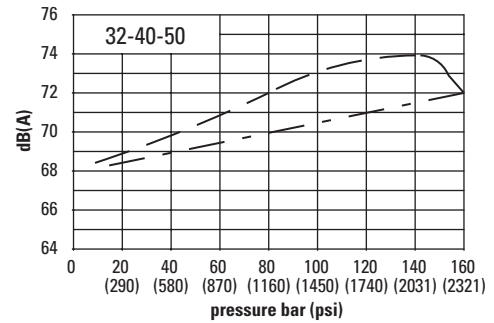

VVP2-50

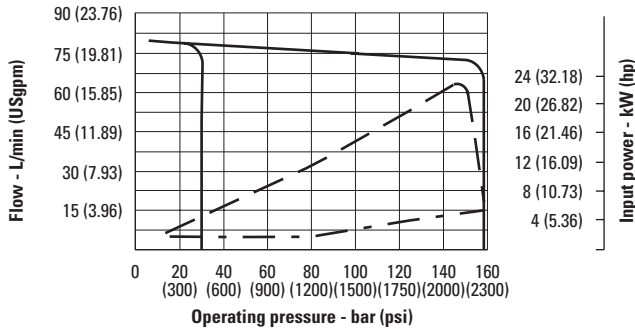

VVP2-32, -40, -50

Response time and pressure peak

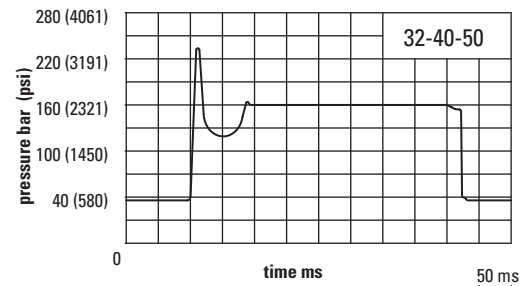

Performance Characteristics

VVP3

Performance with:

Speed 1450 r/min
 Oil per ISO 6743/4
 Viscosity 32 mm²/s (cSt)
 Temperature 50°C (122°F)

Power consumption with maximum flow



Power consumption with zero flow setting



VVP3-63

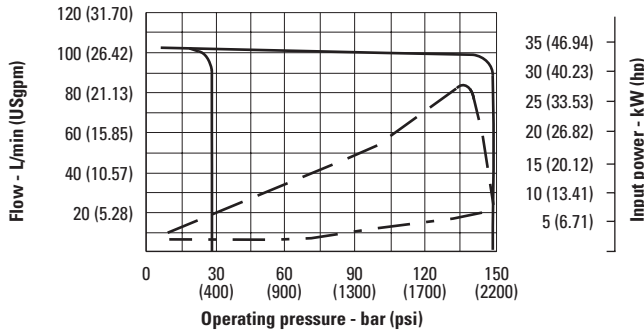

VVP3-63, -80, -100

Values established with zero flow setting

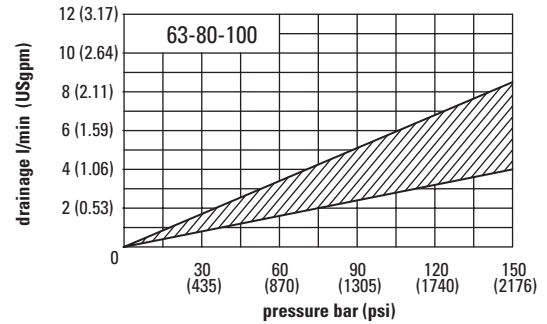

VVP3-80

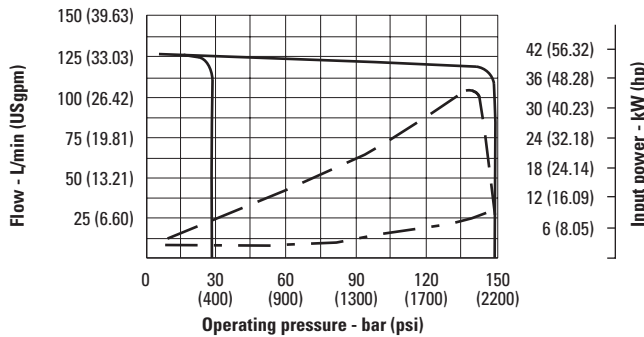

VVP3-63, -80, -100

Maximum noise level measured with sound-level meter placed at 1 meter [39.37"] from pump, flexible coupling.

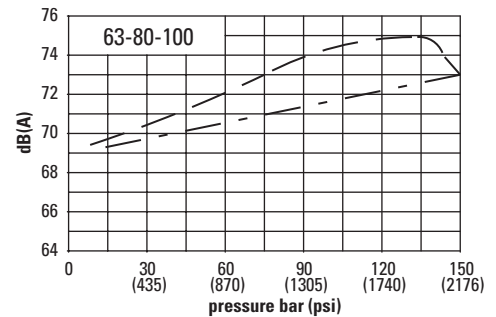

VVP3-100

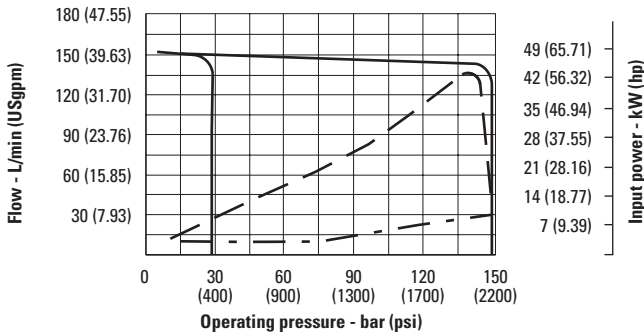

VVP3-63, -80, -100

Response time and pressure peak

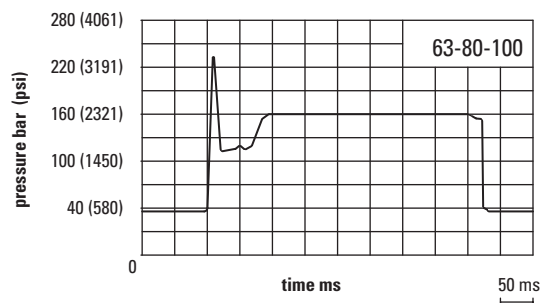

VVP1

With ISO or SAE Mounting Flange

Installation Dimensions
in mm (in)

All mounting flange, port and shaft options are listed on page 36.



"C" Control With "K" Adjustment

"KL" adjustment is shown on page 35.

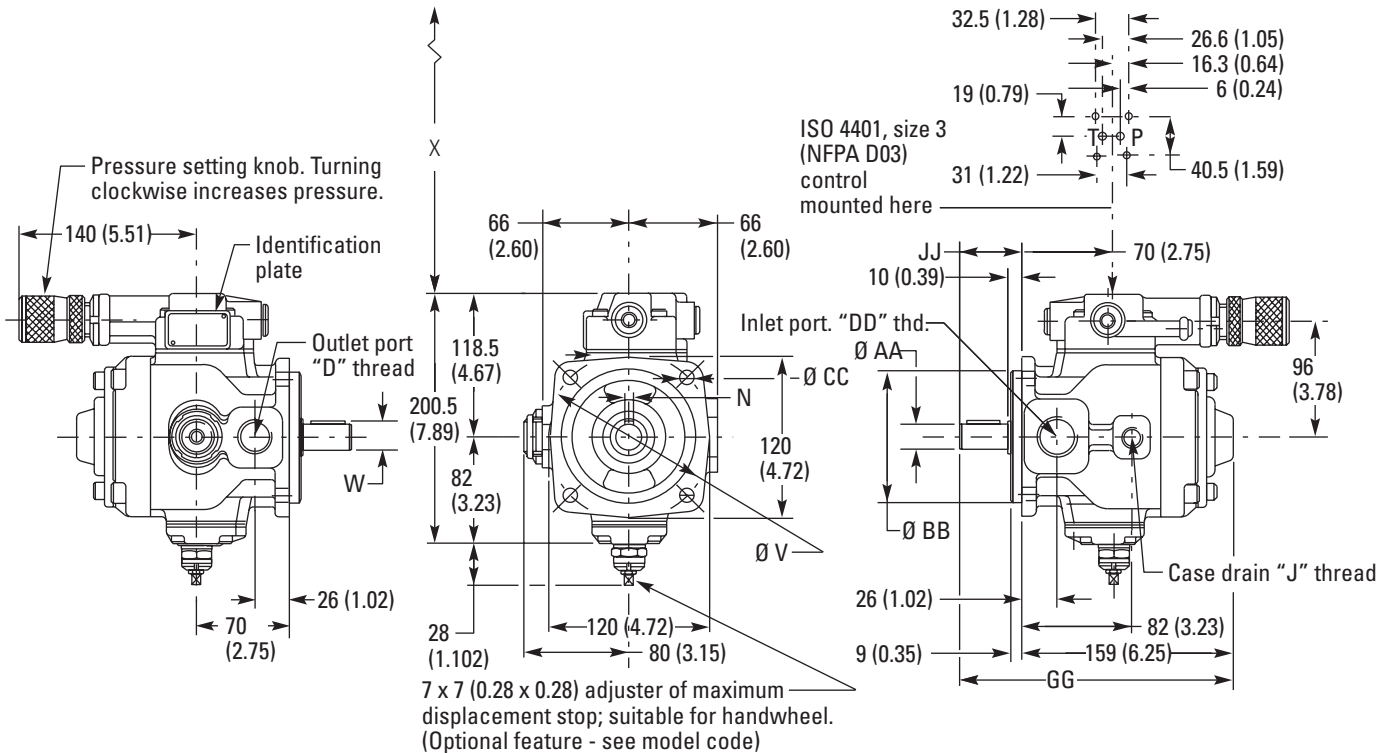

Thread for remote control connection, type CR = dimension "F".
Thread for load sense connection, type CV* = dimension "F".

MOUNTING FLANGE AND PORTS CODE ▲	D	F	J	N	Ø V	W	Ø AA	Ø BB	Ø CC	DD	GG	JJ
R (ISO)	3/4" BSP	1/4" BSP	3/8" BSP	8 (0.315)	125 (4.921)	28 (1.102)	25 (0.984)	100 (3.937)	11.0 (0.433)	1" BSP	205 (8.07)	46 (1.81)
PS (SAE)	1.0625-12 UNF-2B	0.500-20 UNF-2B	0.5625-18 UNF-2B	6.35 (0.250)	127 (5.000)	28.17 (1.109)	25.4 (1.000)	101.6 (4.000)	14.3 (0.56)	1.3125-12 UNF-2B	207 (8.15)	48 (1.89)

▲ See model code, page 15.

VVP CONTROL	CR	CD1	CD2	CE	CVP	CVPR	CVPD1	CVPD2	CVPCE	CVT(*)
Dimension "X"	20.0 (0.79)	100.0 ◆ (3.94) ◆	146.0 ◆ (5.75) ◆	125.5 ◆ (4.94) ◆	20.0 (0.79)	40.0 (1.57)	120.0 ◆ (4.72) ◆	166.0 ◆ (6.54) ◆	145.5 ◆ (5.73) ◆	115.0 (4.55)

◆ Includes 13 (0.51) for removal of DIN connector.

VVP2 and VVP3

With ISO Mounting Flange

Installation Dimensions
in mm (in)

All mounting flange, port and shaft options are listed on page 36.



"C" Control With "K" Adjustment

"KL" adjustment is shown on page 35.

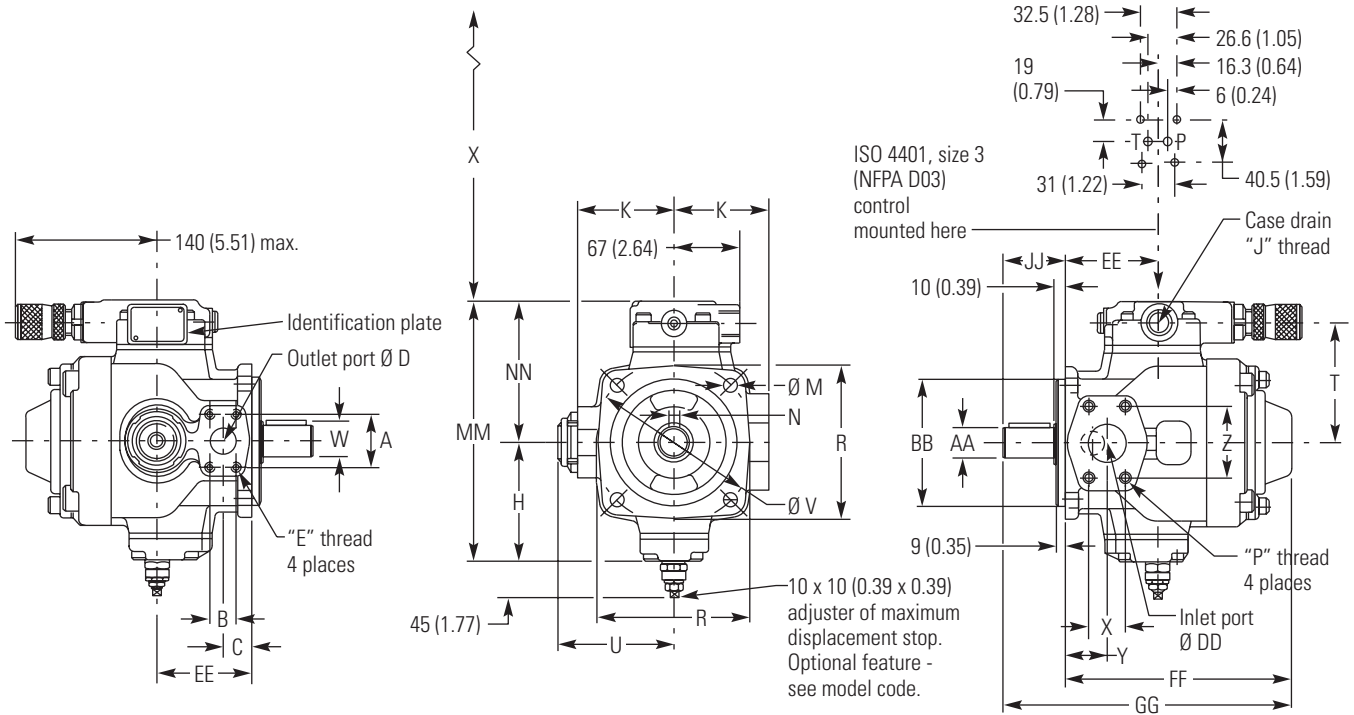

Thread for remote control or load sense connection, type CR or CV* = 1/4" BSP.

MODEL	A	B	C	D	E	H	J	K	Ø M	N	P	R	T
VVP2	52.4 (2.06)	26.2 (1.03)	30 (1.18)	25 (0.98)	M10 or 0.375-16 UNC-2B ▲	110 (4.33)	3/4" BSP or 1.0625-12 UNF-2B ▲	95 (3.74)	14 (0.55)	10 (0.39)	M12 or 0.500-13 UNC-2B ▲	150 (5.91)	123 (4.84)
VVP3	58.7 (2.31)	30.2 (1.19)	35 (1.378)	32 (1.26)	M10 or 0.4375-14 UNC-2B ▲	120 (4.72)	3/4" BSP or 1.0625-12 UNF-2B ▲	105 (4.13)	18 (0.71)	12 (0.47)	M12 or 0.500-13 UNC-2B ▲	185 (7.28)	133 (5.24)

▲ See mounting flange/port connections codes RF and PX, page 15.

MODEL	U	Ø V	W	X	Y	Z	Ø AA	Ø BB	Ø DD	EE	FF	GG	JJ	MM	NN
VVP2	114 (4.49)	160 (6.30)	35 (1.38)	35.7 (1.41)	40 (1.58)	70 (2.76)	32 (1.26)	125 (4.92)	38 (1.50)	91 (3.58)	219 (8.62)	279 (10.98)	60 (2.36)	255.5 (10.06)	145.5 (5.728)
VVP3	123 (4.84)	200 (7.87)	43 (1.69)	43 (1.69)	46 (1.81)	77.8 (3.06)	40 (1.57)	160 (6.30)	51 (2.01)	105 (4.13)	245 (9.65)	313 (12.32)	68 (2.68)	275.5 (10.85)	155.5 (6.12)

VVP CONTROL	CR	CD1	CD2	CE	CVP	CVPR	CVPD1	CVPD2	CVPCE	CVT(*)
Dimension "X"	20.0 (0.79)	100.0 ◆ (3.94) ◆	146.0 ◆ (5.75) ◆	125.5 ◆ (4.94) ◆	20.0 (0.79)	40.0 (1.57)	120.0 ◆ (4.72) ◆	166.0 ◆ (6.54) ◆	145.5 ◆ (5.73) ◆	115.0 (4.55)

◆ Includes 13 (0.51) for removal of DIN connector.

VVP2 and VVP3

With SAE Mounting Flange

Installation Dimensions
in mm (in)

All mounting flange, port and shaft options are listed on page 36.



"C" Control With "K" Adjustment

"KL" adjustment is shown on page 35.

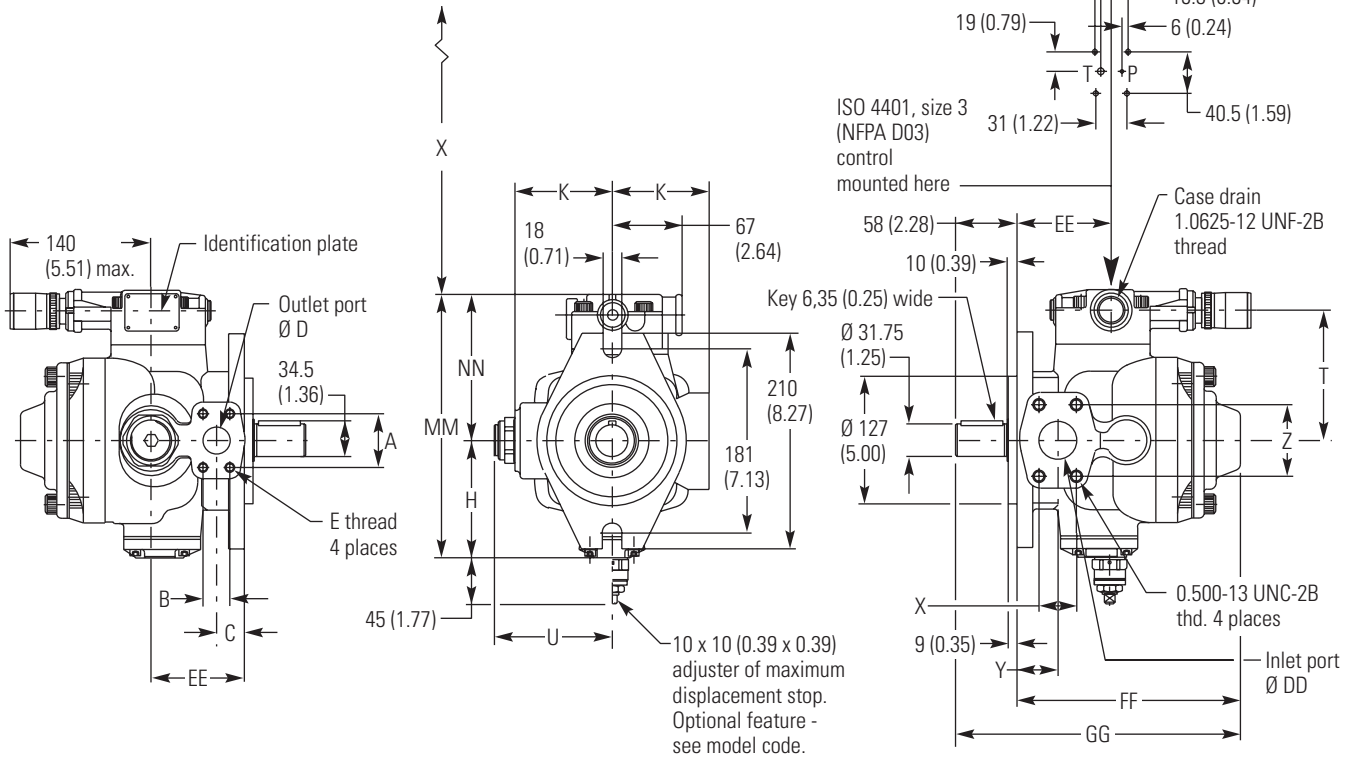

Thread for remote control or load sense connection, type CR or CV* = 0.500-20 UNF-2B

MODEL	A	B	C	D	E	H	K	T	U
VVP2	52.4 (2.06)	26.2 (1.03)	27 (1.06)	25 (0.98)	0.375-16 UNC-2B	110 (4.33)	95 (3.74)	123 (4.84)	114 (4.49)
VVP3	58.7 (2.31)	30.2 (1.19)	35 (1.38)	32 (1.26)	0.4375-14 UNC-2B	120 (4.72)	105 (4.13)	133 (5.24)	123 (4.84)

MODEL	X	Y	Z	Ø DD	EE	FF	GG	MM	NN
VVP2	35.7 (1.41)	40 (1.58)	70 (2.76)	38 (1.50)	91 (3.58)	219 (8.62)	279 (10.98)	256 (10.08)	145.5 (5.73)
VVP3	43 (1.69)	46 (1.81)	77.8 (3.06)	51 (2.00)	105 (4.13)	245 (9.65)	303 (11.93)	275.5 (10.85)	155.5 (6.12)

VVP CONTROL	CR	CD1	CD2	CE	CVP	CVPR	CVPD1	CVPD2	CVPCE	CVT(*)
Dimension "X"	20.0 (0.79)	100.0 ♦ (3.94) ♦	146.0 ♦ (5.75) ♦	125.5 ♦ (4.94) ♦	20.0 (0.79)	40.0 (1.57)	120.0 ♦ (4.72) ♦	166.0 ♦ (6.54) ♦	145.5 ♦ (5.73) ♦	115.0 (4.55)

♦ Includes 13 (0.51) for removal of DIN connector.

VVS and VVP Based Mounted

Installation Dimensions
in mm (in)

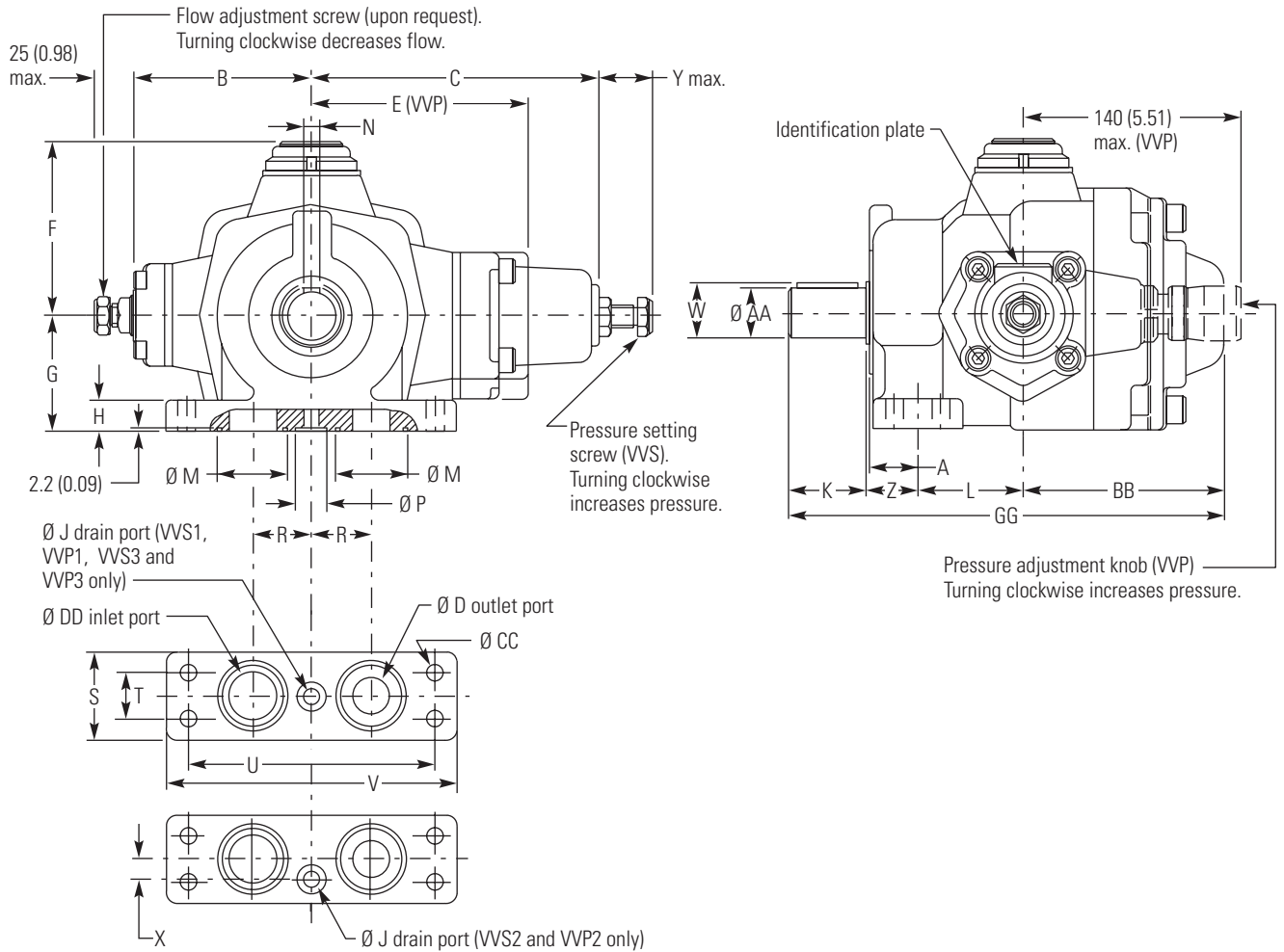

MODEL	A	B	C	Ø D	E	F	G	H	Ø J	K	L	Ø M	N	Ø P
VVS1	25	82	131	14	118.5	80	54	13	6	32	52.5	32.5	5	14
VVP1	(0.98)	(3.23)	(5.16)	(0.55)	(4.67)	(3.15)	(2.13)	(0.51)	(0.24)	(1.26)	(2.07)	(1.28)	(0.20)	(0.55)
VVS2	31	110	175	24	145.5	113	75	20	10	50	68	45.5	10	20.5
VVP2	(1.22)	(4.33)	(6.89)	(0.94)	(5.73)	(4.45)	(2.95)	(0.79)	(0.39)	(1.97)	(2.68)	(1.79)	(0.39)	(0.81)
VVS3	53.5	120	185	28	155.5	123	114	21	13	47	57.5	48	6.35	28
VVP3	(2.11)	(4.72)	(7.28)	(1.10)	(6.12)	(4.84)	(4.49)	(0.83)	(0.51)	(1.85)	(2.26)	(1.89)	(0.25)	(1.10)

MODEL	R	S	T	U	V	W	X	Y	Z	AA	BB	Ø CC	Ø DD	GG
VVS1	25.5	46	25.5	121	140	21	-	30	27	19	89.5	11	21	201
VVP1	(1.00)	(1.81)	(1.00)	(4.76)	(5.51)	(0.83)		(1.18)	(1.06)	(0.75)	(3.52)	(0.43)	(0.83)	(7.91)
VVS2	38	57	30	159	190	35	12.5	40	33	32	129	11	32	280
VVP2	(1.50)	(2.24)	(1.18)	(6.26)	(7.48)	(1.38)	(0.49)	(1.57)	(1.30)	(1.26)	(5.08)	(0.43)	(1.26)	(11.02)
VVS3	57	76	51	247.5	273	27.5	-	40	55.5	25.37	140	13	35	300
VVP3	(2.24)	(2.99)	(2.01)	(9.74)	(10.75)	(1.08)		(1.57)	(2.19)	(1.00)	(5.51)	(0.51)	(1.38)	(11.81)

Combined Pumps

The rotor shaft of Vickers™ variable vane pumps is pre-arranged for mounting an additional pump. Simply take off the rear cover to easily attach the secondary pump. (See items A and B on sectional view, page 4.)

Vickers™ combined standard pumps (see table below) eliminate the need for many “special application” pumps.

For solutions other than those shown in the table, contact your Eaton representative.

Typical Pump Combinations

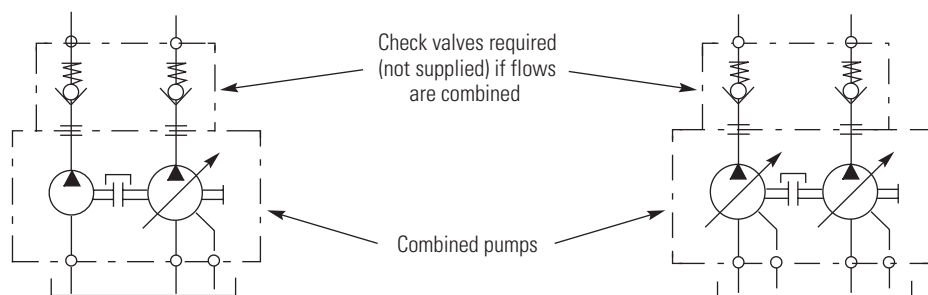

Components for Combining Pumps

PRIMARY PUMP	SECONDARY PUMP	ADAPTER KIT	PART NO.	MAX. TORQUE ON DRIVE SHAFT FOR SECONDARY PUMP
VV*1-***-R/PS	VVS0-R	AK-VVS/VVP1-0-R	02-358847	55 Nm (487 lbf-in)
	VVS0-PS	AK-VVS/VVP1-0-PS	02-358848	
	VV*1-R	AK-VVS/VVP1-1-R	02-358849	
	VV*1-PS	AK-VVS/VVP1-1-PS	02-358850	
	SAE A 2-bolt ▲	AK-VVS/VVP1-SAE-A	02-358851	
VV*2/3-RF/PF	VVS0-R	AK-VVS/VVP2/3-0-R ●	02-358852	110 Nm (974 lbf-in)
	VVS0-PS	AK-VVS/VVP2/3-0-PS ●	02-358853	
	VV*1-R	AK-VVS/VVP2/3-1-R ●	02-358717	
	VV*1-PS	AK-VVS/VVP2/3-1-PS ●	02-358854	
	VV*2-RF/PX	AK-VVS/VVP2/3-2-RF/PX ●	02-358855	
	SAE A 2-bolt ▲	AK-VVS/VVP2/3-SAE-A ●	02-358856	
	SAE B 2-bolt ▲	AK-VVS/VVP2/3-SAE-B ●	02-358857	
VV*3-RF/PF	VV*3-RF/PX	AK-VVS/VVP3-3-RF/PX	02-358858	180 Nm (1593 lbf-in)

▲ SAE A and B 2-bolt are generic interfaces. Secondary pump with SAE A or B mount should conform to dimensions on the following page.

● Adapter kits for same displacements within frame sizes 2 and 3 primary pumps are identical.

Ordering Combined Pumps

Order pumps and coupling unit in progressive order of coupling.

Example:

One (1) VVP1-20-RR-M-30-CVTCE03B-15-10 Primary Pump

One (1) AK-VVS/VVP1-0-R Adapter Kit

One (1) VVS0-10-RR-M-40-CCW-10 Secondary Pump

Combined Pumps (continued)

Secondary pumps with SAE A or B 2-bolt mounts should conform to the dimensions below. Dimensions in millimeters (inches).

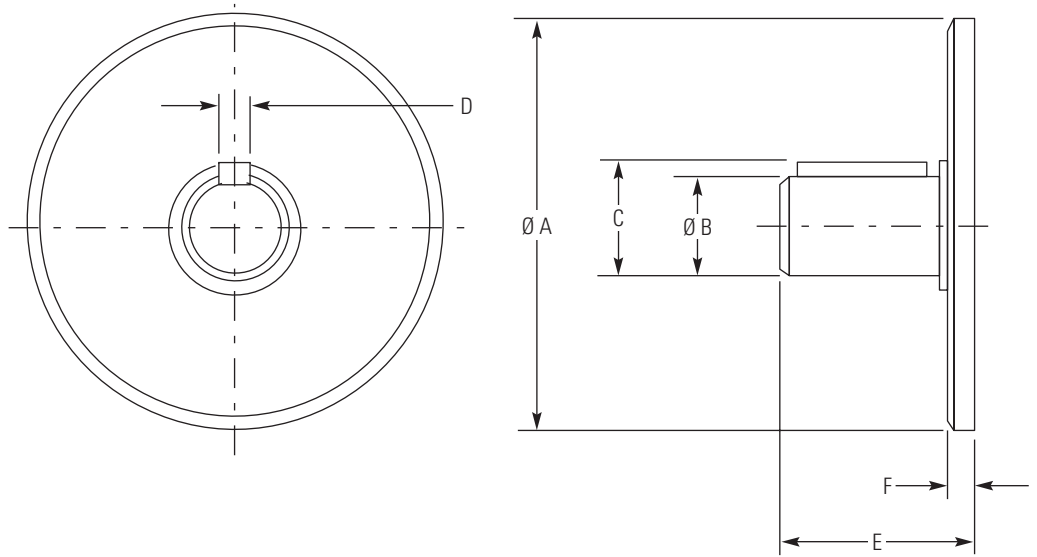

PRIMARY PUMP	2-BOLT FLANGE OF SECONDARY PUMP ▲	ADAPTER KIT	Ø A	Ø B	C	D	E MAX.	F
VVS1 VVP1	SAE A	AK-VVS/VVP1-SAE-A	82.5 (3.25)	19.05 (0.75)	21.1 (0.83)	4.8 (0.19)	50 (1.97)	7 (0.28)
VVS2 VVP2	SAE A	AK-VVS/VVP2/3-SAE-A	82.5 (3.25)	19.05 (0.75)	21.1 (0.83)	4.8 (0.19)	60 (2.36)	7 (0.28)
VVS3 VVP3	SAE B	AK-VVS/VVP2/3-SAE-B	101.6 (4.00)	22.2 (0.87)	25.1 (0.99) ●	6.375 (0.25) ●		9.5 (0.37)
					25.5 (1.00) ●	4.8 (0.19) ●		

- ▲ Secondary pumps with ISO mounting flange are listed on page 28.
- Both shafts are accommodated within same coupling.

Torque Requirements Combined Pumps

Combined pumps must be installed in decreasing order of displacement. Torque requirements and limitations of single and combined pumps must not exceed the values shown in the tables below.

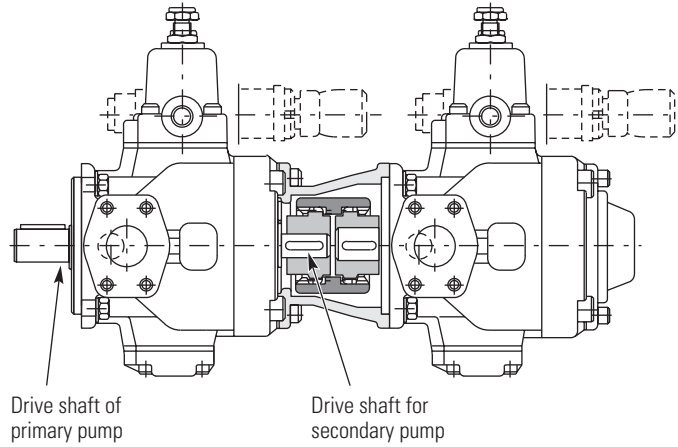

Pump Frame Size 1

PUMP TYPE	REQUIRED TORQUE FOR PRIMARY PUMP Nm (lbf-in)	MAXIMUM TORQUE ON DRIVE SHAFT FOR SECONDARY PUMP Nm (lbf-in)
VVS1-16	30 (266)	
VVS1-20	37 (327)	
VVS1-25	46 (407)	55 (487)
VVP1-16	47 (416)	
VVP1-20	58 (513)	
VVP1-25	73 (646)	

Pump Frame Size 2

PUMP TYPE	REQUIRED TORQUE FOR PRIMARY PUMP Nm (lbf-in)	MAXIMUM TORQUE ON DRIVE SHAFT FOR SECONDARY PUMP Nm (lbf-in)
VVS2-32	57 (504)	
VVS2-40	73 (646)	
VVS2-50	91 (805)	110 (974)
VVP2-32	92 (814)	
VVP2-40	117 (1036)	
VVP2-50	146 (1292)	

Pump Frame Size 3

PUMP TYPE	REQUIRED TORQUE FOR PRIMARY PUMP Nm (lbf-in)	MAXIMUM TORQUE ON DRIVE SHAFT FOR SECONDARY PUMP Nm (lbf-in)
VVS3-63	92 (814)	
VVS3-80	117 (1036)	
VVS3-100	146 (1292)	180 (1593)
VVP3-63	172 (1522)	
VVP3-80	219 (1938)	
VVP3-100	273 (2416)	

Dimensions

Combined Pumps

Installation Dimensions
in mm (in)

VVS1 or VVP1 Primary Pump With VVS1 or VVP1 Secondary Pump

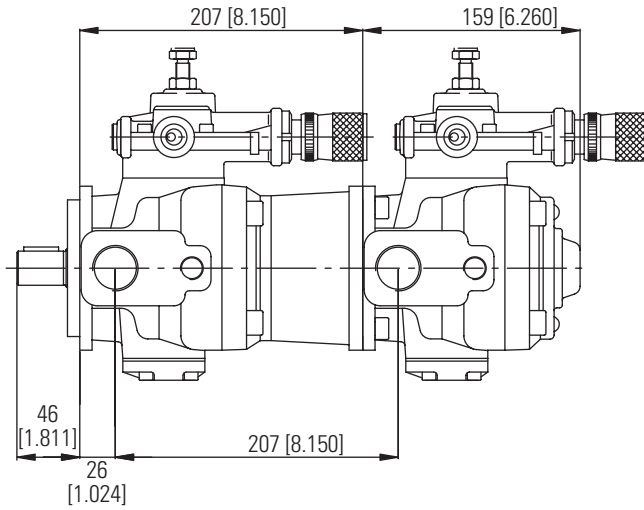

MOUNTING FLANGE & PORT CODE	A
R	46 (1.81)
PS	48 (1.89)

VVS1 or VVP1 Primary Pump With VVS0 Secondary Pump

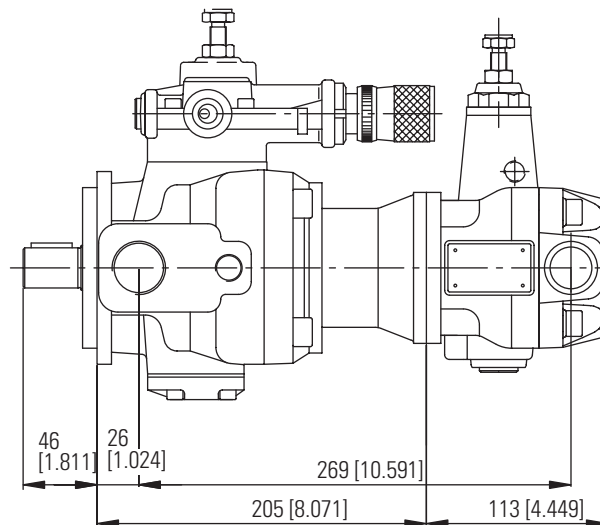

MOUNTING FLANGE & PORT CODE	A
R	46 (1.81)
PS	48 (1.89)

Dimensions

Combined Pumps (continued)

Installation Dimensions
in mm (in)

VVS2 or VVP2 Primary Pump With VVS2 or VVP2 Secondary Pump

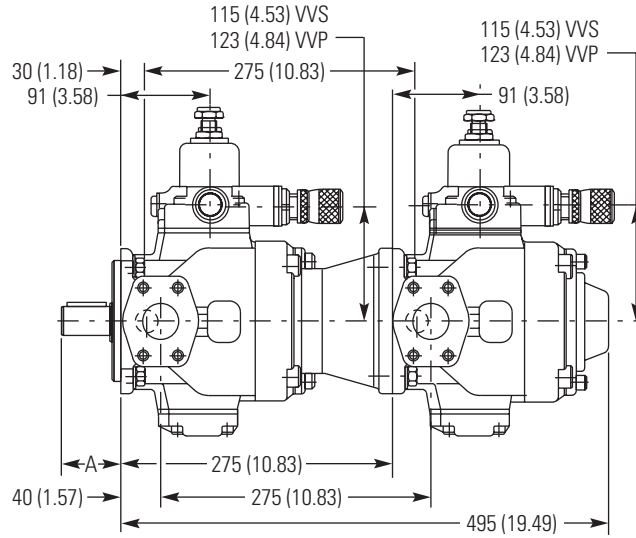

**MOUNTING FLANGE
& PORT CODE**

	A
RF	60 (2.36)
PF	58 (2.28)

VVS2 or VVP2 Primary Pump With VVS1 or VVP1 Secondary Pump

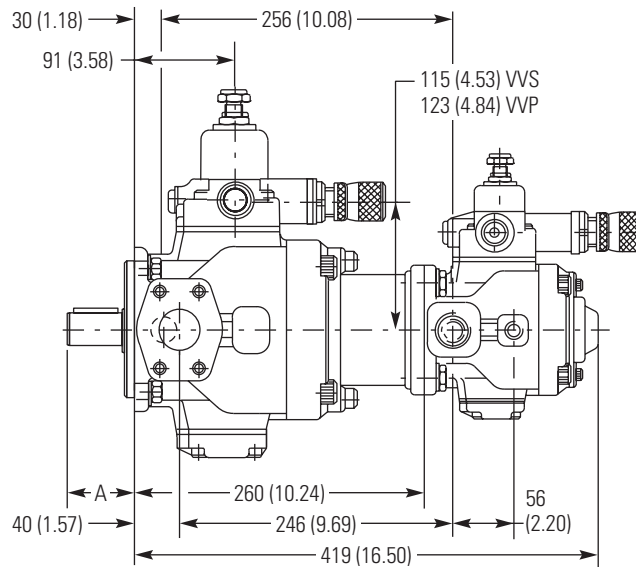

**MOUNTING FLANGE
& PORT CODE**

	A
RF	60 (2.36)
PF	58 (2.28)

Dimensions Combined Pumps (continued)

Installation Dimensions
in mm (in)

VVS2 or VVP2 Primary Pump With VVS0 Secondary Pump

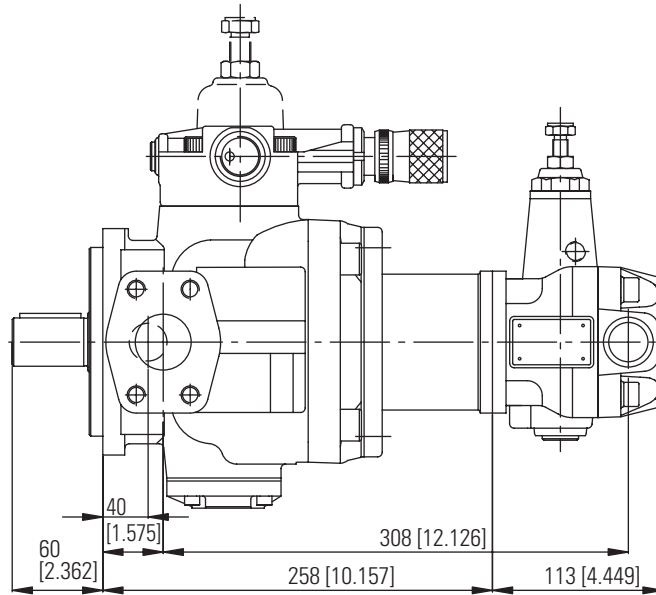

MOUNTING FLANGE & PORT CODE	A
RF	60 (2.86)
PF	58 (2.28)

VVS3 or VVP3 Primary Pump With VVS3, VVP3, VVS2 or VVP2 Secondary Pump

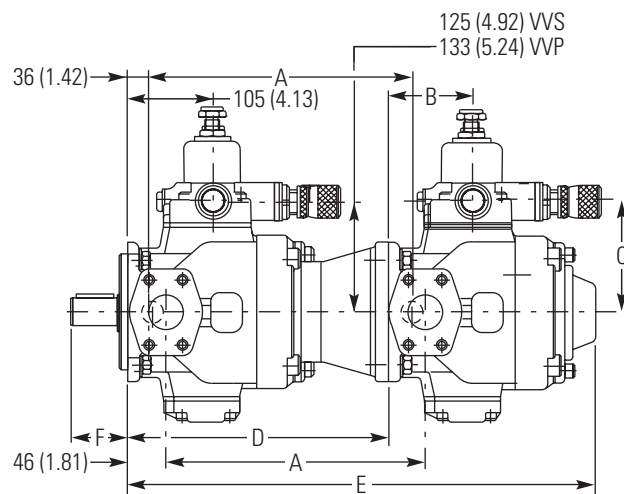

MOUNTING FLANGE & PORT CODE	F
RF	68 (2.68)
PF	58 (2.28)

SECONDARY PUMP	A	B	C	D	E
VVS3, VVP3	315 (12.40)	105 (4.13)	125 (4.92) VVS3 133 (5.24) VVP3	315 (12.40)	560 (22.05)
VVS2, VVP2	294 (11.57)	91 (3.58)	115 (4.53) VVS2 123 (4.84) VVP2	300 (11.81)	520 (20.47)

Dimensions

Combined Pumps (continued)

Installation Dimensions
in mm (in)

VVS3 or VVP3 Primary Pump With VVS1 or VVP1 Secondary Pump

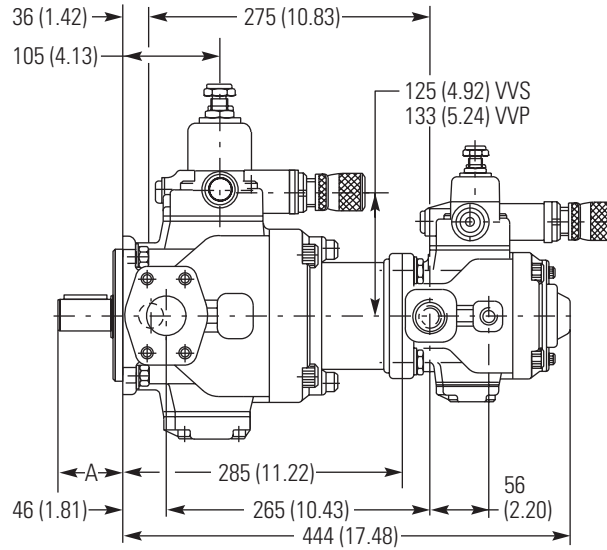

MOUNTING FLANGE & PORT CODE

	A
RF	68 (2.68)
PF	58 (2.28)

VVS3 or VVP3 Primary Pump With VVS0 Secondary Pump

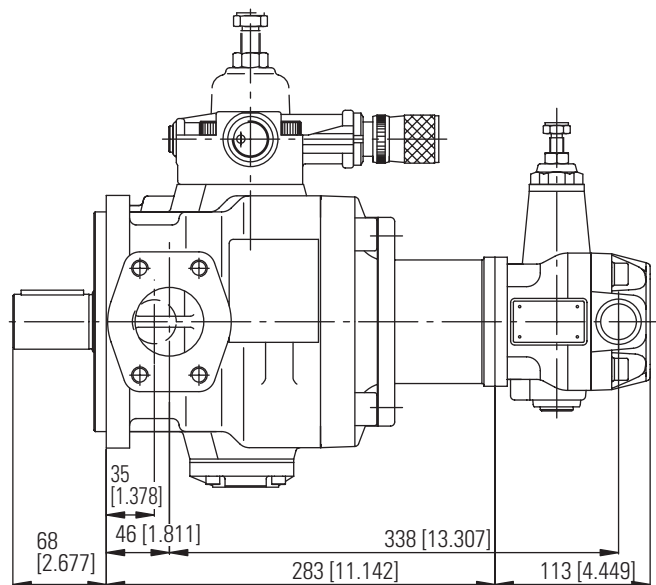

MOUNTING FLANGE & PORT CODE

	A
RF	68 (2.68)
PF	58 (2.28)

Key Lock Adjustment for VVP Pumps

Installation Dimensions
in mm (in)



“KL” Adjustment For VVP1, VVP2 and VVP3 Single Pumps

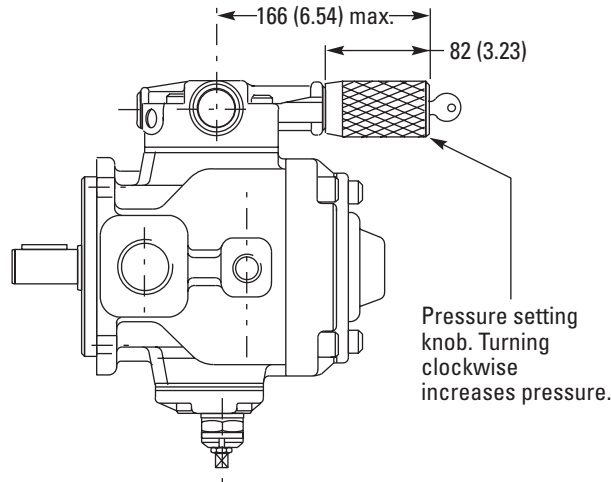

“KL” Adjustment For VVP1, VVP2 and VVP3 Combined Pumps

Note: Because of length, controls on combined pumps are mounted perpendicular to pump shaft.

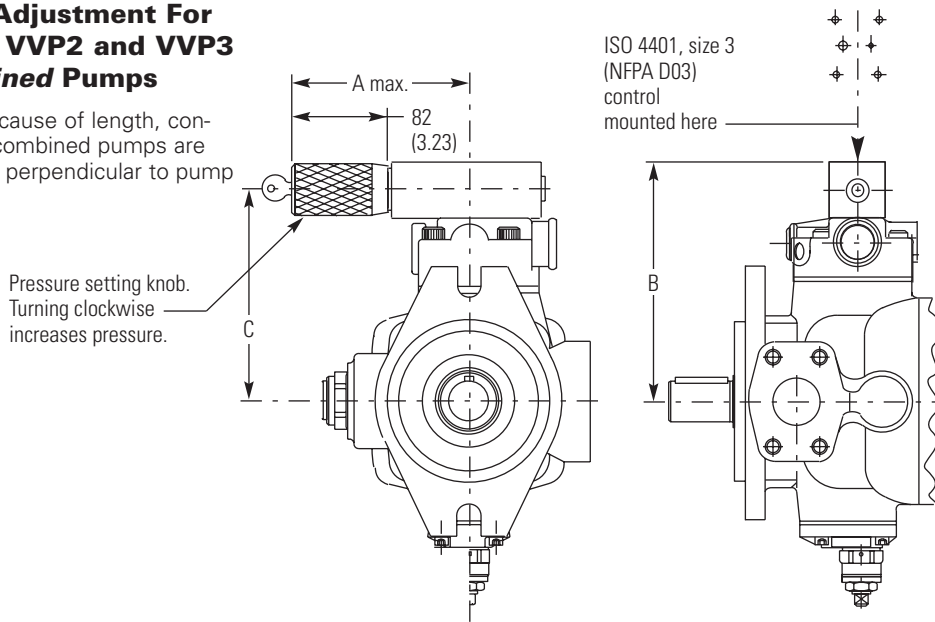

PUMP	A	B	C
VVP1	162 (6.38)	162 (6.38)	139 (5.47)
VVP2	155 (6.10)	189 (7.44)	166 (6.54)
VVP3	155 (6.10)	199 (7.83)	176 (6.93)

Mounting, Shaft and Port Options

Installation Dimensions
in mm (in)

Mountings and Shafts

FRAME SIZE	MTG. FLANGE & PORTS CODE	ISO MOUNTING FLANGE		SAE MOUNTING FLANGE		FRONT END DIAMETER	SHAFT LENGTH	REAR END DIAMETER	SHAFT LENGTH
		PILOT DIA.	BOLT CIRCLE DIA.	PILOT DIA.	BOLT CIRCLE DIA.				
0	R	80 (3.15)	103 (4.06)	-	-	20 (0.79)	36 (1.42)	-	-
	PS	80 (3.15)	103 (4.06)	-	-	15.88 (0.625)	24 (0.938)	-	-
1	B	-	-	-	-	19 (0.75)	32 (1.26)	-	-
	R	100 (3.94)	125 (4.92)	-	-	25 (0.98)	36 (1.42)	20 (0.79)	26 (1.02)
	PS	-	-	101.6 (4.000)	127 (5.000)	25.4 (1.00)	38 (1.50)	20 (0.79)	26 (1.02)
2	B	-	-	-	-	32 (1.26)	50 (1.97)	-	-
	RF	125 (4.92)	160 (6.30)	-	-	32 (1.26)	50 (1.97)	28 (1.10)	45 (1.77)
	PF	-	-	127 (5.000)	180 (7.09)	31.75 (1.25)	48 (1.88)	28 (1.10)	45 (1.77)
	PX	125 (4.92)	160 (6.30)	-	-	32 (1.26)	50 (1.97)	28 (1.10)	45 (1.77)
3	B	-	-	-	-	25.37 (1.00)	47 (1.85)	-	-
	RF	160 (6.30)	200 (7.87)	-	-	40 (1.57)	58 (2.28)	28 (1.10)	45 (1.77)
	PF	-	-	127 (5.000)	180 (7.09)	31.75 (1.25)	48 (1.88)	28 (1.10)	45 (1.77)
	PX	160 (6.30)	200 (7.87)	-	-	40 (1.57)	58 (2.28)	28 (1.10)	45 (1.77)

Ports

FRAME SIZE	MTG. FLANGE & PORTS CODE	INLET PORT	OUTLET PORT	DRAIN PORT VVS PUMPS	DRAIN PORT VVP PUMPS	REMOTE PRESSURE CONTROL, LOAD SENSING AND DUAL-PRESSURE LOAD SENSING PORTS
0	R	G 3/4" BSP	G 3/8" BSP	G 1/4" BSP	-	-
	PS	1.0625-12 UNF-2B	0.750-16 UNF-2B	0.500-20 UNF-2B	-	-
1	B	21 (0.83)	14 (0.55)	6 (0.24)	6 (0.24)	-
	R	G 1" BSP	G 3/4" BSP	G 3/8" BSP	G 3/8" BSP	G 1/4" BSP
	PS	1.3125-12 UNF-2B	1.0625-12 UNF-2B	0.5625-18 UNF-2B	0.5625-18 UNF-2B	0.500-20 UNF-2B
2	B	32 (1.26)	24 (0.94)	10 (0.39)	10 (0.39)	-
	RF	1.50 SAE 4-bolt flange with M12 x 45 deep mounting holes	1.00 SAE 4-bolt flange with M10 x 35 deep mounting holes	G 1/2" BSP	G 3/4" BSP	G 1/4" BSP
	PF	1.50 SAE 4-bolt flange with 0.500 UNC x 1.75 deep mounting holes	1.00 SAE 4-bolt flange with 0.375-16 UNC x 1.50 deep mounting holes	0.875-14 UNF-2B	1.0625-12 UNF-2B	0.500-20 UNF-2B
	PX					
3	B	35 (1.38)	28 (1.10)	13 (0.51)	13 (0.51)	-
	RF	2.00 SAE 4-bolt flange with M12 x 45 deep mounting holes	1.25 SAE 4-bolt flange with M10 x 40 deep mounting holes	G 1/2" BSP	G 3/4" BSP	G 1/4" BSP
	PF PX	2.00 SAE 4-bolt flange with 0.500 UNC x 1.75 deep mounting holes	1.25 SAE 4-bolt flange with 0.375-16 UNC x 1.75 deep mounting holes	0.875-14 UNF-2B	1.0625-12 UNF-2B	0.500-20 UNF-2B

Installation Instructions

- 1) Pump frame sizes 0 and 1 can be mounted in any position. Pump frame sizes 2 and 3 **must** be mounted with horizontal axis and the compensator device upward (see figure). When the pump is installed over the tank oil level, it is recommended to pay attention to the inlet pressure. The minimum section of the inlet pipe must be equal to the section of the thread inlet port of the pump. The inlet pipes should be as short as possible, with a small number of bends and without inside section changes.
- 2) All return and drain pipes must be placed so that the oil will be not re-sucked directly from the pump (see figure). The oil tank must be suitably sized in order to exchange the thermal power generated to the system

components and to have a low re-cycle speed. To ensure maximum pump working life, inlet oil temperature must never be above 50°C (122°F). In the systems where the pump runs for a long time in zero flow setting condition, it is recommended to install a heat exchanger in the drain line. The pressure on the drain port must never be in excess of the specified value. The drain pipe must always be independent of other return lines, connected directly to the tank and extended sufficiently inside the tank so as to be below the minimum oil level in order to avoid generating foam. Moreover, the drain pipe must be free of restrictions and as far as possible away from the inlet pipe.

3) Motor-pump coupling must

be made with a self-aligning coupling with convex teeth and with cam in polyamide material. When assembling, maximum attention must be given to the distance between the two half-couplings which must imperatively fall within the value specified in the diagram below (detail "A"). Other types of motor - pump couplings are not permitted. No induced RADIAL or AXIAL LOADS are allowed on the pump shaft.

- 4) During the first installation, the pump must be run in maximum flow condition (P connected to T), with the oil flowing directly into the tank, thus to induce air bleeding. For sizes 2 and 3 there is an air bleed placed on the compensator device. This phase must go on for several minutes. Pump priming (oil out-

put to the delivery side) must occur within a few seconds, otherwise the pump must be turned off and the operation repeated. Subsequent start-ups in zero flow setting conditions are admissible only with pressure not exceeding 30 bar (435 psi), and at condition that the system and pump be completely filled up with oil. During the starting operations, both the first and the followings, the difference between the oil temperature and the environment temperature (body pump temperature) must not exceed by more than 20°C (68°F).

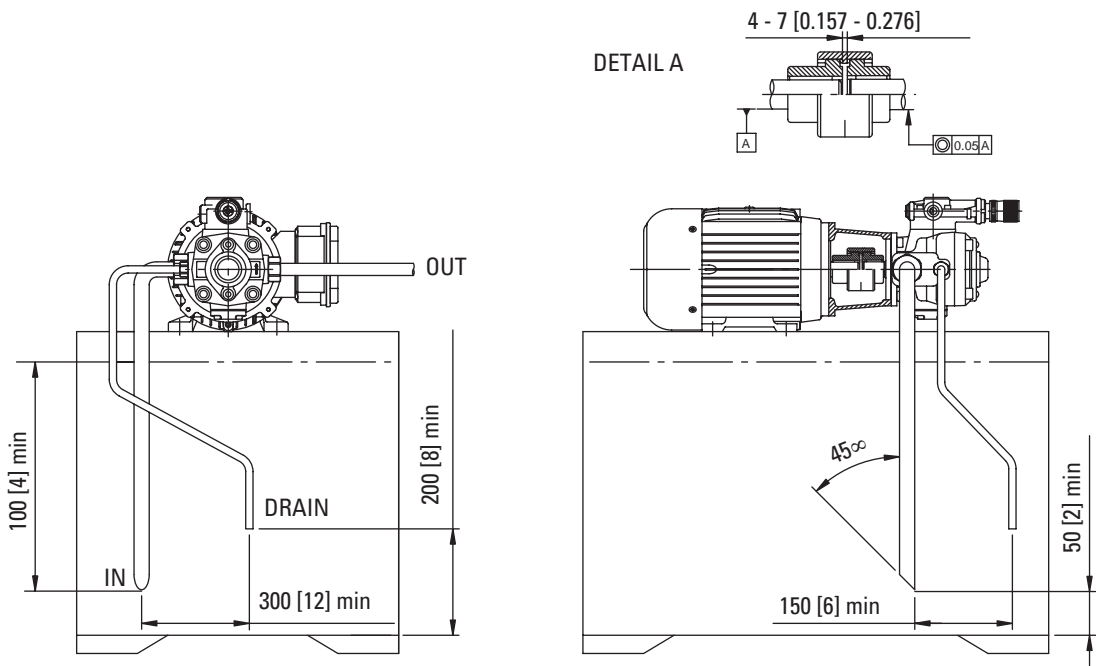

CENTRALA ELBLĄG

Ul. Rawska 19B
82-300 Elbląg

tel. /+48/ 55 625 51 00

fax /+48/ 55 625 51 01

Dział Handlowy

tel. /+48/ 55 625 51 51

elblag@hydropress.pl



www.hydropress.pl

ODDZIAŁ GDAŃSK

tel. /+48/ 55 625 51 21

fax /+48/ 55 625 51 22

ODDZIAŁ RUMIA

tel. /+48/ 58 679 34 15

fax /+48/ 55 625 51 25

ODDZIAŁ TYCHY

tel. /+48/ 32 787 52 88

fax /+48/ 55 625 51 38

ODDZIAŁ OLSZTYN

tel. /+48/ 89 532 01 05

fax /+48/ 89 715 21 42

ODDZIAŁ WARSZAWA

tel. /+48/ 22 468 86 97

fax /+48/ 55 625 51 32

BIURO WE WROCŁAWIU

tel. /+48/ 782 838 000

fax /+48/ 55 625 51 35

BIURO W KIELCACH

tel. /+48/ 885 995 501

fax /+48/ 55 625 51 01

BIURO W KRAKOWIE

tel. /+48/ 885 995 019

fax /+48/ 55 625 51 01

BIURO W OPOLU

tel. /+48/ 885 995 011

fax /+48/ 55 625 51 01

BIURO W BYDGOSZCZY

tel. /+48/ 790 222 771

fax /+48/ 55 625 51 01

BIURO W BIAŁYMSTOKU

tel. /+48/ 89 532 01 05

fax /+48/ 89 715 21 42

BIURO W ŁODZI

tel. /+48/ 609 221 421

fax /+48/ 89 715 21 42