



# POMIAR PRZEPLÝWU CIECZY

Przepływomierze turbinowe  
Webtec typ CT-R-SR

# CTR Series

## Turbine flow meters with conditioned output and built-in loading valve

Up to

- 800 lpm, 210 US gpm
- 480 bar, 7000 psi

Output Options

- 4 - 20 mA, 0 - 5 V

The CTR series of turbine flow meters with built-in loading valve, provide a complete solution to the flow measurement of hydraulic systems on test stands, machine tools and other fixed or mobile applications. The flow meter can be installed anywhere in the hydraulic circuit for production testing, commissioning, development testing and control systems. The compact design allows the CTR series flow meters to be installed where space is limited.

The integral loading valve provides smooth progressive pressure control in both flow directions allowing components such as cylinders or motors to be tested without re-plumbing the test connections.

The CTR turbine flowmeter has a built-in micro-processor that conditions the signal from the flowmeter to provide an accurate analogue output. This enables you to connect the flowmeter directly into your digital display, PLC or custom DAQ system. Two versions are available offering 4 - 20 mA current loop or 0 - 5 V.

\* Greater flow accuracy is obtained in the forward direction.



CTR mA model shown

Hydraulic measurement and control



Milwaukee, WI 53235, USA

Tel: +1 (414) 769-6400

sales-us@webtec.com

St. Ives, Cambs. PE27 3LZ, UK

Tel: +44 (0) 1480 397 400

sales-uk@webtec.com

www.webtec.com

### Features

- **FLOW:** 8 - 800 lpm, 2 - 210 US gpm
- **PRESSURE:** Up to 480 bar, 7000 psi
- **OUTPUT OPTIONS:** 4 - 20 mA or 0 - 5 V
- **LOADING VALVE:** with bi-directional flow and pressure loading capability \*
- **'INTERPASS™'** safety disc system, bypasses oil internally in the event of the valve being over pressurised
- **FLUIDS:** Wide range of hydraulic oil, lubrication oils, and fuels
- **CALIBRATION:** 21 cSt as standard. Special calibration possible
- **COMPREHENSIVE** range of accessories available including pressure transducers, temperature sensors panel meters and cables. See bulletins MPT, TP125 and DP130 for details or consult sales office



Certificate No.8242

## Specifications

Model Number	Outputs available	Main ports	Top ports	Flow range	Max. pressure
CT300R**-B-B-6	5V, mA	1" BSPP	1/4" BSPP	8 - 300 lpm	420 bar
CT300R**-S-S-6	5V, mA	1-5/16" -12UN #16 SAE ORB	7/16" -20UN #4 SAE ORB	2 - 80 US gpm	6000 psi
CT400R**-B-B-6	5V, mA	1" BSPP	1/4" BSPP	10 - 400 lpm	420 bar
CT400R**-S-S-6	5V, mA	1-5/16" -12UN #16 SAE ORB	7/16" -20UN #4 SAE ORB	2.5 - 100 US gpm	6000 psi
CT600R**-F-B-3	5V, mA	1-1/2" #24 SAE Code 61 4-bolt flange	1/4" BSPP	20 - 600 lpm	210 bar
CT600R**-F-S-3	5V, mA	1-1/2" #24 SAE Code 61 4-bolt flange	7/16" -20UN #4 SAE ORB	5 - 160 US gpm	3000 psi
CT600R**-S-B-7	5V, mA	1-7/8" -12UN #24 SAE ORB	1/4" BSPP	20 - 600 lpm	480 bar
CT600R**-S-S-7	5V, mA	1-7/8" -12UN #24 SAE ORB	7/16" -20UN #4 SAE ORB	5 - 160 US gpm	7000 psi
CT800R**-F-B-3	5V, mA	1-1/2" #24 SAE Code 61 4-bolt flange	1/4" BSPP	20 - 800 lpm	210 bar
CT800R**-S-B-7	5V, mA	1-7/8" -12UN #24 SAE ORB	1/4" BSPP	20 - 800 lpm	480 bar
CT800R**-F-S-3	5V, mA	1-1/2" #24 SAE Code 61 4-bolt flange	7/16" -20UN #4 SAE ORB	5 - 210 US gpm	3000 psi
CT800R**-S-S-7	5V, mA	1-7/8" -12UN #24 SAE ORB	7/16" -20UN #4 SAE ORB	5 - 210 US gpm	7000 psi

CT600R, 800R has limited pressure control below 86 lpm (23 US gpm). The maximum controllable pressure in this region is calculated by: max pressure (in bar) = 5 x flow (lpm) +30

### Functional specification

**Ambient temperature:** 5 to 40 °C (41 - 104 °F)  
**Fluid type:** Oils, fuels, water glycol, water oil emulsions  
**Fluid temperature:** 5 to 90 °C (41 - 194 °F) continuous use.  
**Accuracy:** 15 to 100% of range - 1% of indicated reading  
 Below 15% fixed accuracy of 1% of 15% of full scale  
**Repeatability:** Better than ± 0.2%  
**Response Time:** 50 m/s + 1 period  
**Degree of protection\*:** CTR-mA, CTR-5V- IP66 (EN60529) \*With cable connected

### Electrical specification

**Supply voltage (VS):** mA & 5V = 12 - 32 VDC  
**Current output:** 4 - 20 mA, 3 wire loop, max loop resistance = (VSx50) - 200 ohms  
**Voltage output:** 0 - 5 VDC, current consumption=10mA, minimum load 20K ohms

### Construction material

**Flow body:** High tensile Aluminium 2014A T6  
**Internal parts:** Aluminium, Steel, Stainless Steel.  
**Transducer:** Body and nut - steel 212A42 electroless nickel plated, Lid and housing - Aluminium 2011 T3  
**Seals:** Viton seals as standard EPDM are available - please consult sales office.

### Operation

There are two key elements - the turbine and the loading valve. As fluid is passed through the flow block it rotates a precision turbine. The flow straighteners and turbine design minimise the effects of turbulence and swirl. The turbine blades are detected by the magnetic reluctance transducer which produces a pulse output. The flow meter block has ports for pressure or temperature sensors which can be supplied as an option.

The loading valve unique design has a pressure-balanced poppet that ensures low handle effort throughout the flow and pressure ranges in addition to excellent tactile feedback, regardless of flow direction. Tuning the valve clockwise increases the restriction and hence the load on the circuit. In the event of overpressure, replaceable safety discs (situated within the poppet) rupture, to internally by-pass the oil at low pressure. Safety discs with different pressure ranges up to 480 bar are available -please consult sales office.

### Reverse flow

The flow block is capable of controlling and measuring flow in either direction. There is a shuttle valve which ensures the pressure port measure the high pressure side of the loading valve. In order to achieve the quoted accuracy figures flow must be in the preferred direction - turbine first then loading valve.

### Calibration

All units are calibrated with 21 cSt oil as standard. Calibration certificates are available on request - this is a chargeable option. Other calibration on request - please consult the sales office.

### Installation

The flow blocks have built-in flow straighteners so the normal recommended length of 10Ø of straight tube can be reduced to 8 Ø where space is limited. 90-degree bends are permitted on the loading valve end of the block, but should always be of a similar bore size to that of the flowmeter to prevent venturi or constriction effects. The range of flow meters can be used for intermittent or continuous testing of flow in either direction. The flow block can be mounted in any orientation.

### Filtration

It is recommended that a 25-micron filter is installed in the circuit prior to the flow block.

### Top ports

All flow meters have two additional ports (see table for configuration) in the top face to enable the user to connect both a temperature and pressure sensor. All flow meters come with one M16 x 2 test point fitted as standard.

### Ordering

To order a flow meter please quote the model number from the table above. eg: CT300R-MA-B-B-6. All flow meters can have both a temperature sensor and pressure transducer connected simultaneously.

## Pressure Drop Chart

Hydraulic Oil Viscosity 21 Centistokes (fully open load valve)

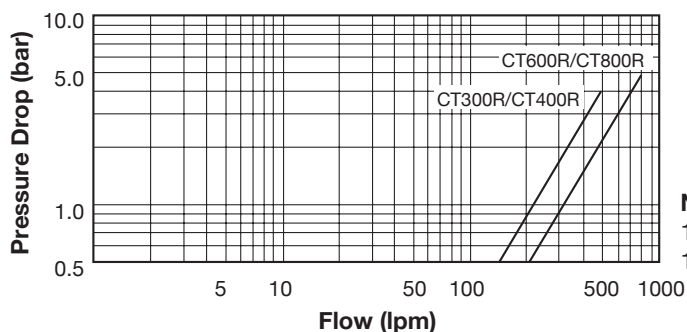

**Note**  
 1 UK gallon = 4.546 litres  
 1 US gallon = 3.785 litres

## Connection Details

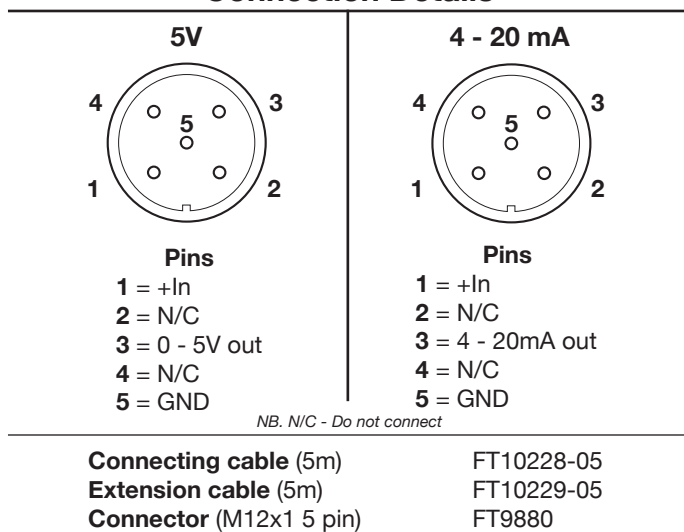

Dimensions in mm (inches)

Model No	A	B	C	D	E	F	G	Weight kg (lbs)
CT300R	49 (2")	100 (4")	182 (7-1/8")	222 (8-3/4")	102.5 (4")	47.6 (1-7/8")	138 (5-1/2")	3.7 (8.1)
CT400R	49 (2")	100 (4")	182 (7-1/8")	222 (8-3/4")	102.5 (4")	47.6 (1-7/8")	138 (5-1/2")	3.7 (8.1)
CT600R	75 (3")	125 (5")	211 (8-3/8")	235 (9-3/4")	99 (3-7/8")	63 (2-1/2")	157 (6-1/8")	7.5 (16.5)
CT800R	75 (3")	125 (5")	211 (8-3/8")	235 (9-3/4")	99 (3-7/8")	63 (2-1/2")	157 (6-1/8")	7.5 (16.5)

Add 20mm (3/4") to G for full height including feet.

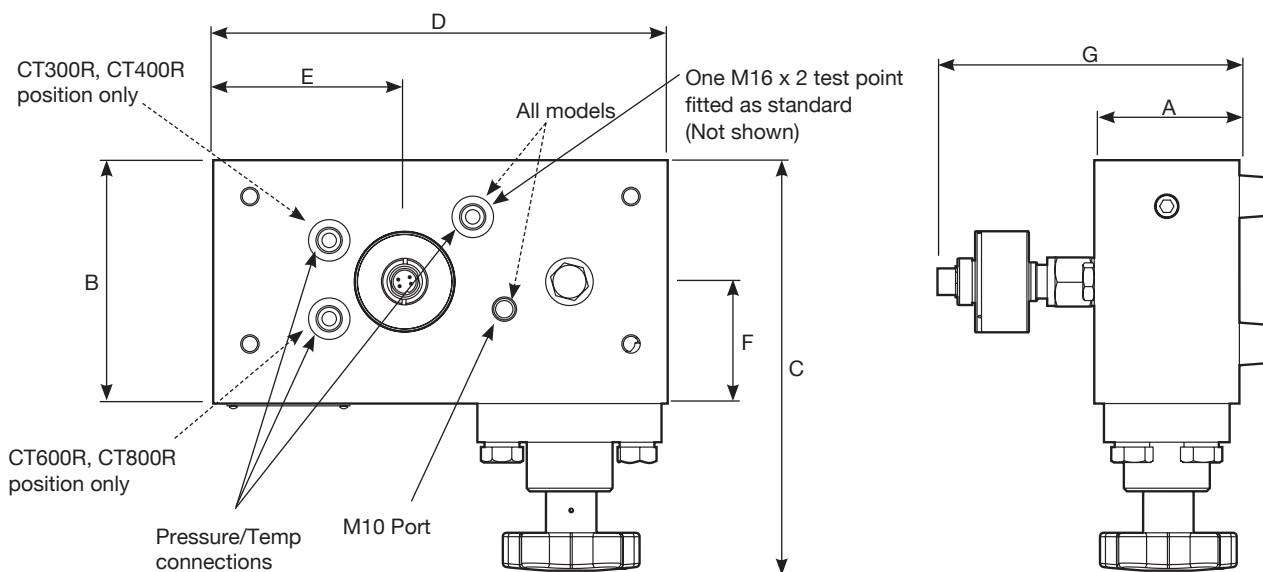

## Turbine Flow Meters

### Accuracy

The accuracy is better described as the uncertainty of the flow reading compared to a known reference. Every flow measurement has an error associated with it, caused by the combination of a large number of factors that affect the operation of the flow meter, these include bearing friction, temperature, viscosity, magnetic drag and the signal strength to name but a few.

All our flow meters are calibrated at 10 points over the flow range and its performance measured against a flow reference that is traceable to International standards. Accuracy is typically quoted in one of two ways: as a percentage of full scale (the maximum calibrated flow) or as a percentage of the indicated reading (the actual flow).

### Full scale (FS) or full scale deflection (FSD)

A term that was originally used for analogue displays where a needle pointed to a number on a scale, hence FSD. The flow accuracy is a fixed amount regardless of the actual flow you are measuring. For example 1% FS for a flow meter with a maximum calibrated flow of 400 lpm is  $\pm 4$  lpm whether you are measuring 40 lpm, 200 lpm or 400 lpm (see graph below). If you need to measure flows of 40 and 400 lpm with same flow meter then it is important to check the allowable error at all flows.

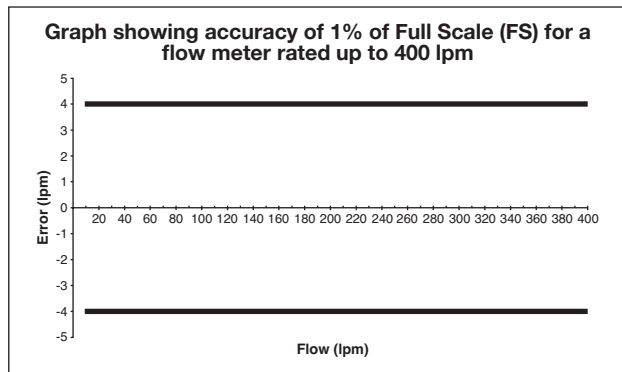

### Indicated reading (IR)

Accuracy is quoted as a percentage of the actual value measured. So if the accuracy of a 400 lpm flow meter is 1% IR then the error at 400 lpm is  $\pm 4$  lpm. As the actual flow measured reduces, so does the error in lpm. When measuring a flow of 60 lpm with an accuracy of 1% IR, the possible error is  $\pm 0.6$  lpm. At very low flows, the possible errors are no longer proportional to the flow rate, but actually a fixed amount in lpm (see graph below). For example if the accuracy is quoted as 1% IR (>60 lpm) for a flow meter with the range 10 - 400 lpm, then the accuracy is 1% of the actual flow in the range 60 to 400 lpm and a fixed flow error in the range 10 to < 60 lpm.

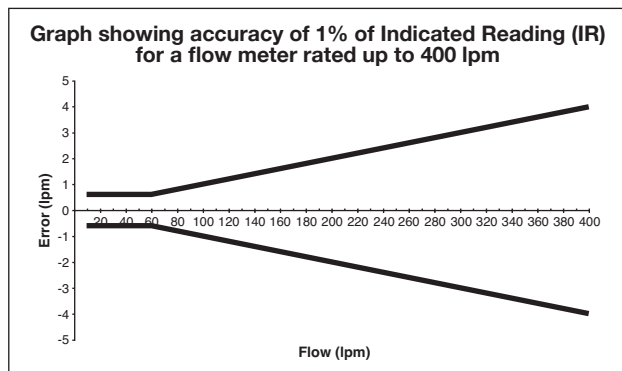

### Repeatability

The repeatability is the variation in the performance of the flow meter when used under the same conditions. Our range of flow meters has excellent repeatability of better than  $\pm 0.2\%$ . This is just as important as the accuracy since in many applications the flow readings from the same flow meter will be compared at regular intervals to look for any change in performance of the system.

### Flow range (Turndown ratio)

A turbine flow meter has a minimum and a maximum calibrated flow which together describe the range of flows that can be accurately measured. Through the addition of signal conditioning either mounted on the flow meter or built into the readout, the flow range of our flow meters has been extended considerably compared to other models on the market; the ratio of the maximum to the minimum calibrated flow (turndown ratio) is between 15 and 40 across all models. Particular effort has been made to extend the flow range by calibrating down to lower flows enabling one flow meter to be used where two may have been required in the past. This makes the flow meter both a more economical and easier to install solution.

### Fluid viscosity

The performance of a turbine flow meter can be affected by the viscosity of the fluid measured. Our turbine flow meters are calibrated at between 18 and 26 cSt as standard (a mean viscosity of 21 cSt), which is the typical kinematic viscosity for a hydraulic fluid operating at 50 °C. The kinematic viscosity of all hydraulic fluids is related to the fluid temperature and the table below shows the affect of temperature on the kinematic viscosity of a range of typical grades of hydraulic oil.

The shaded area of the table shows the range of viscosities that can be measured by a flow meter with standard calibration with minimal effect on the accuracy (less than  $\pm 1\%$  FS).

Flow meters can be specially calibrated at a different viscosity to the standard or we can advise on the expected error when the flow meter is used at other viscosities, please contact sales for further information.

**Table showing kinematic viscosity (cSt) of different mineral oils at specific temperatures**

Temp °C	Fluid type					
	ISO15	ISO22	ISO32	ISO37	ISO46	ISO68
0	85.9	165.6	309.3	449.9	527.6	894.3
10	49.0	87.0	150.8	204.7	244.9	393.3
20	30.4	50.5	82.2	105.5	127.9	196.1
30	20.1	31.6	48.8	59.8	73.1	107.7
40	14.0	21.0	31.0	36.6	44.9	63.9
50	10.2	14.7	20.8	23.9	29.4	40.5
60	7.7	10.7	14.7	16.5	20.2	27.2
70	6.0	8.1	10.9	12.0	14.6	19.2
80	4.8	6.4	8.4	9.1	11.1	14.3
90	4.0	5.2	6.6	7.2	8.7	11.1
100	3.3	4.3	5.5	6.0	7.1	8.9

ISO 15, 22, 32, 46 and 68 based on typical figures for the Esso Nuto range of HM oils. ISO 37 based on Shell Tellus HM oil.



APPROVED

## CENTRALA ELBLĄG

ul. Rawska 19B  
82-300 Elbląg

tel. /+48/ 55 625 51 00

fax /+48/ 55 625 51 01

### Dział Handlowy

tel. /+48/ 55 625 51 51

elblag@hydropress.pl



[www.hydropress.pl](http://www.hydropress.pl)

### ODDZIAŁ GDAŃSK

tel. /+48/ 55 625 51 21

fax /+48/ 55 625 51 22

### ODDZIAŁ RUMIA

tel. /+48/ 58 679 34 15

fax /+48/ 55 625 51 25

### ODDZIAŁ TYCHY

tel. /+48/ 32 787 52 88

fax /+48/ 55 625 51 38

### ODDZIAŁ OLSZTYN

tel. /+48/ 89 532 01 05

fax /+48/ 89 715 21 42

### ODDZIAŁ WARSZAWA

tel. /+48/ 22 468 86 97

fax /+48/ 55 625 51 32

### BIURO WE WROCŁAWIU

tel. /+48/ 782 838 000

fax /+48/ 55 625 51 35

### BIURO W KIELCACH

tel. /+48/ 885 995 501

fax /+48/ 55 625 51 01

### BIURO W KRAKOWIE

tel. /+48/ 885 995 019

fax /+48/ 55 625 51 01

### BIURO W OPOLU

tel. /+48/ 885 995 011

fax /+48/ 55 625 51 01

### BIURO W BYDGOSZCZY

tel. /+48/ 790 222 771

fax /+48/ 55 625 51 01

### BIURO W BIAŁYMSTOKU

tel. /+48/ 89 532 01 05

fax /+48/ 89 715 21 42

### BIURO W ŁODZI

tel. /+48/ 609 221 421

fax /+48/ 89 715 21 42