

*Winner*



# ZAWORY DZIELNIKI STRUMIENIA

## FLOW DIVIDER/COMBINER VALVES

Ordering Code: **FD-10W-X-Y-Z**

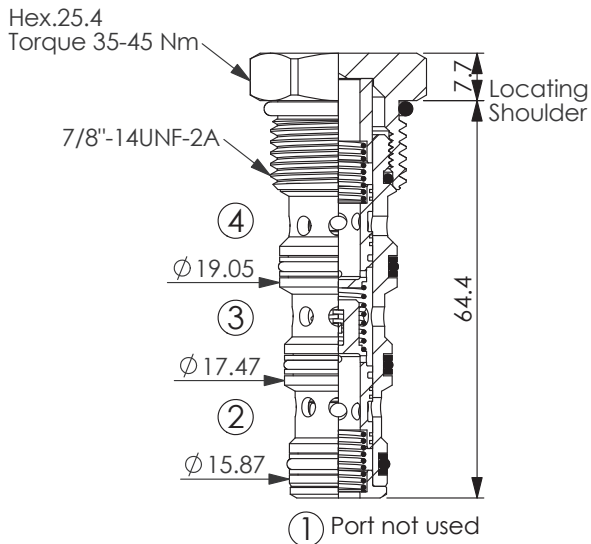

UNIT:mm

- (1)The FD10W-40 will divide input flow from ① to ② and ③, based on the ratio specified, regardless of operating pressure.
- (2)The valve will combine input flow from both ② and ③ to ①.
- (3)Should either ② or ③ become blocked in flow division mode.

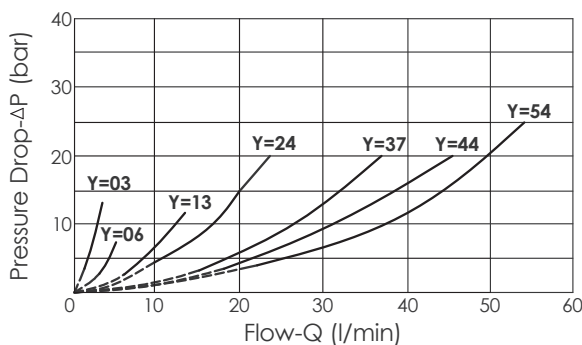

Y	NOMINAL CAPACITY	
03	1.2-3 LPM	Ratio 50:50
06	3-6 LPM	Ratio 50:50
13	6-13 LPM	Ratio 50:50
24	10-24 LPM	Ratio 50:50
37	15-37 LPM	Ratio 50:50
44	18-44 LPM	Ratio 50:50
54	22-54 LPM	Ratio 50:50

Other ratio options available; consult factory

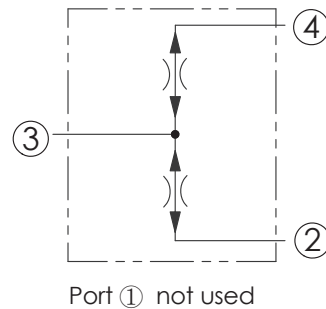

### TECHNICAL DATA

Pressure min-max: 10-350 bar  
28 bar pressure drop at max. flow

Rated Input Flow: 54 l/min

Cavity-Tooling: 10W-4

Installation torque: 35-45 Nm

Weight: 0.11 (Z:N,NP) kg

Fluids-Temperatures: -40 to 120 °C

Flow Accuracy: 10% from 40-100%  
of Max.Input flow

Filtration: 25 μm nominal or better

Mounting Position: unrestricted

X	OPERATION	
40	4 Ports; Flow Divider/Combiner	

Z	OPTION	
N	Non-adjustable	
NP	Non-adjustable With stainless steel external metal components (Buna-N Seal)	

Ordering Code: **FD-16W-X-Y-Z**

Hex.38  
Torque 60-70 Nm

1-5/16"-12UN-2A

④  
Ø 28.60

③  
Ø 27.00

②  
Ø 25.42

12.6

104

UNIT:mm

① Port not used

(1)The FD10W-40 will divide input flow from ③ to ② and ④, based on the ratio specified, regardless of operating pressure.  
 (2)The valve will combine input flow from both ② and ④ to ③.  
 (3)Should either ② or ④ become blocked in flow division mode.

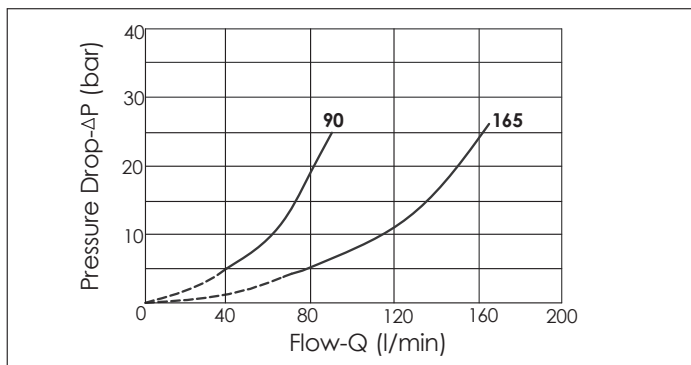

Y	NOMINAL CAPACITY
90	30-90 LPM Ratio 50:50
165	50-165 LPM Ratio 50:50
Other ratio options available;consult factory	

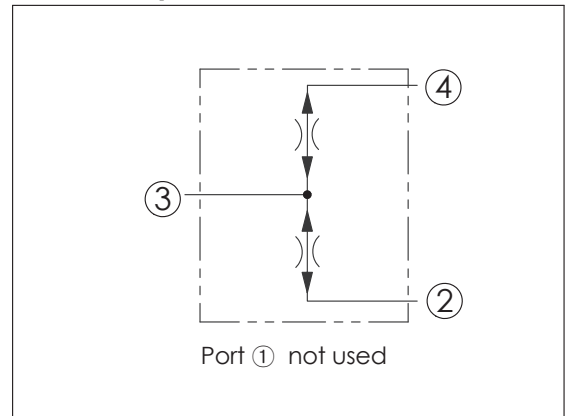

TECHNICAL DATA	
Pressure min-max:	10-350 bar 28 bar pressure drop at max.flow
Rated Input Flow:	165 l/min
Cavity-Tooling:	16W-4
Installation torque:	60-70 Nm
Weight:	0.38 kg
Fluids-Temperatures:	-40~120 °C
Flow Accuracy:	10% from 40-100% of Max.Input flow
Filtration:	25 μm nominal or better
Mounting Position:	unrestricted

X	OPERATION
40	4 Ports; Flow Divider/Combiner

Z	OPTION
N	Non-adjustable

## FLOW DIVIDER VALVES

Ordering Code: **FD-10W-X-Y-Z**

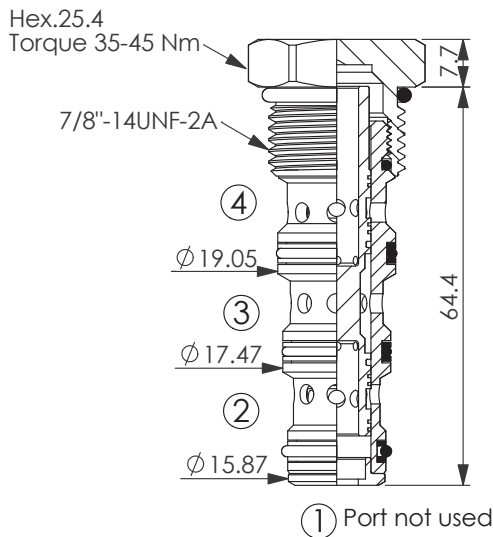

UNIT:mm

- (1)The FD10W-41 will divide input flow from to and based on the ratio specified,regardless of operating pressure.  
 (2)Should either or become blocked in flow division mode.  
 (3)NOTE:Flow combining is not permitted.

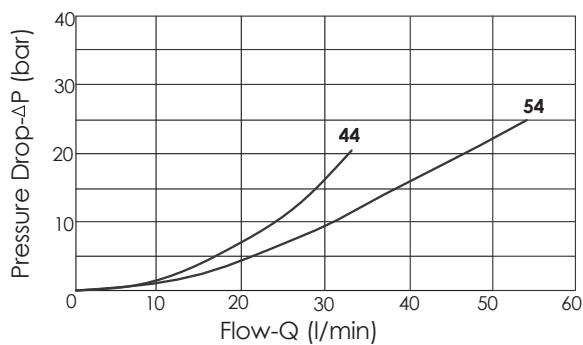

Y	NOMINAL CAPACITY
37	15-37 LPM Ratio 50:50
44	18-44 LPM Ratio 50:50
54	22-54 LPM Ratio 50:50
Other ratio options available;consult factory	

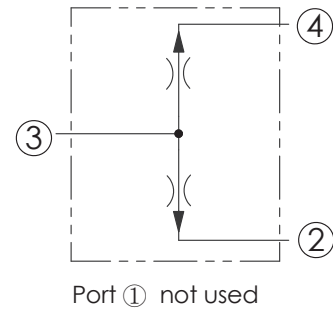

### TECHNICAL DATA

Pressure min-max: 10-350 bar  
 28 bar pressure drop at max.flow

Rated Input Flow: 54 l/min

Cavity-Tooling: 10W-4

Installation torque: 35-45 Nm

Weight: 0.11 kg

Fluids-Temperatures: -40~120 °C

Flow Accuracy: 10% from 40-100%  
 of Max.Input flow

Filtration: 25 μm nominal or better

Mounting Position: unrestricted

X	OPERATION
41	4 Ports;Flow Divider

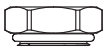
Z	OPTION
N	Non-adjustable 

## FLOW DIVIDER VALVES

Ordering Code: **FD-16W-X-Y-Z**

Hex.38  
Torque 60-70 Nm

1-5/16"-12UN-2A

④

③

②

① Port not used

UNIT:mm

(1)The FD16W-41 will divide input flow from ① to ② and ③, based on the ratio specified, regardless of operating pressure.  
 (2)Should either ② or ③ become blocked in flow division mode.  
 (3)NOTE:Flow combining is not permitted.

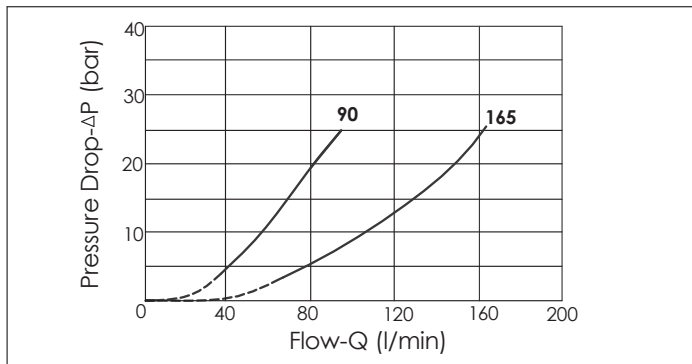

Y	NOMINAL CAPACITY
90	30-90 LPM Ratio 50:50
165	50-165 LPM Ratio 50:50
Other ratio options available;consult factory	

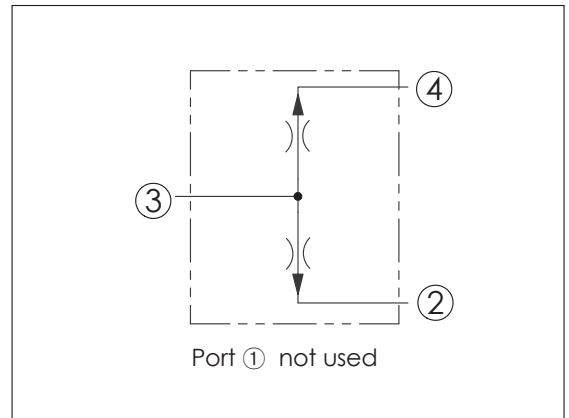

TECHNICAL DATA	
Pressure min-max:	10-350 bar 28 bar pressure drop at max.flow
Rated Input Flow:	165 l/min
Cavity-Tooling:	16W-4
Installation torque:	60-70 Nm
Weight:	0.38 kg
Fluids-Temperatures:	-40~120 °C
Flow Accuracy:	10% from 40-100% of Max.Input flow
Filtration:	25 μm nominal or better
Mounting Position:	unrestricted

X	OPERATION
41	4 Ports;Flow Divider

Z	OPTION
N	Non-adjustable

## FLOW DIVIDER VALVES

Ordering Code: **FD-16W-X-Y-Z-2080**

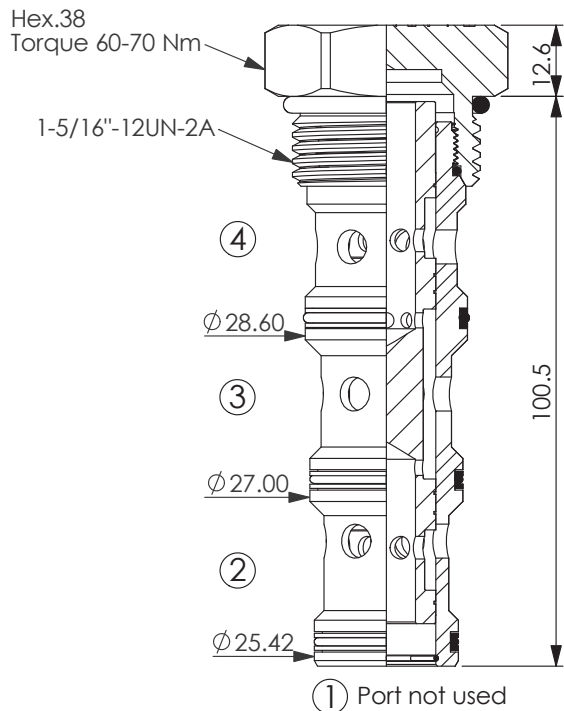

UNIT:mm

- (1)The FD16W-41 will divide input flow from ① to ② and ③, based on the ratio specified, regardless of operating pressure.  
 (2)Should either ② or ③ become blocked in flow division mode.  
 (3)NOTE:Flow combining is not permitted.

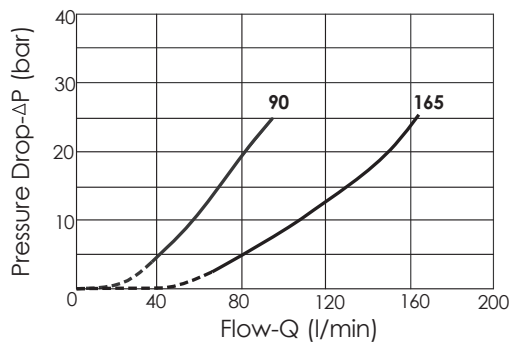

Y	NOMINAL CAPACITY
90	30-90 LPM Ratio 20:80 Port ②:Port ④ = 20:80 (Flow Ratio)
165	50-165 LPM Ratio 20:80 Port ②:Port ④ = 20:80 (Flow Ratio)
	Other ratio options available;consult factory

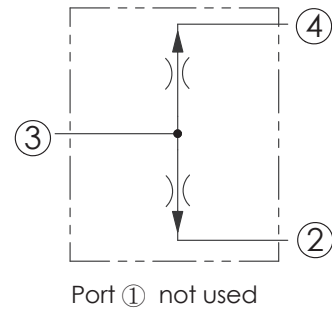

### TECHNICAL DATA

Pressure min-max:	10-350 bar
28 bar pressure drop at max.flow	
Rated Input Flow:	165 l/min
Cavity-Tooling:	16W-4
Installation torque:	60-70 Nm
Weight:	0.38 kg
Fluids-Temperatures:	-40~120 °C
Flow Accuracy:	10% from 40-100% of Max.Input flow
Filtration:	25 μm nominal or better
Mounting Position:	unrestricted

X	OPERATION
41	4 Ports;Flow Divider

Z	OPTION
N	Non-adjustable 

## FLOW DIVIDER VALVES

Ordering Code: **FD-16W-X-Y-Z-7525**

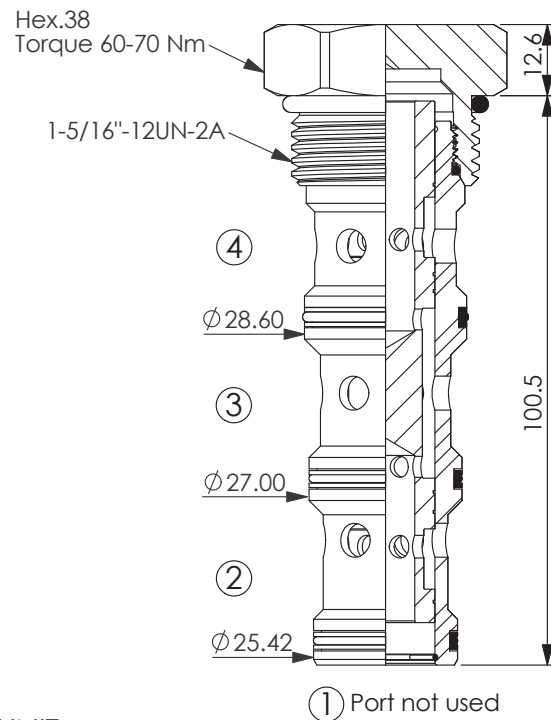

UNIT:mm

- (1) The FD16W-41 will divide input flow from ① to ② and ③, based on the ratio specified, regardless of operating pressure.  
 (2) Should either ② or ③ become blocked in flow division mode.  
 (3) NOTE: Flow combining is not permitted.

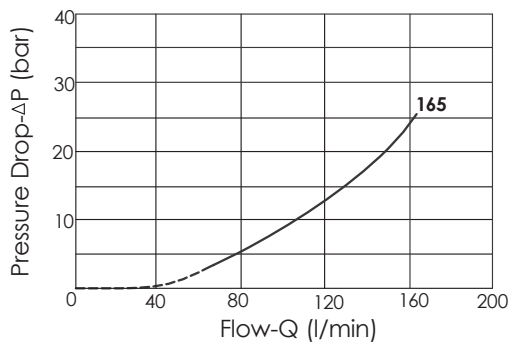

Y	NOMINAL CAPACITY
165	50-165 LPM Ratio 75:25 Port ②:Port ④ = 75:25 (Flow Ratio)
Other ratio options available; consult factory	

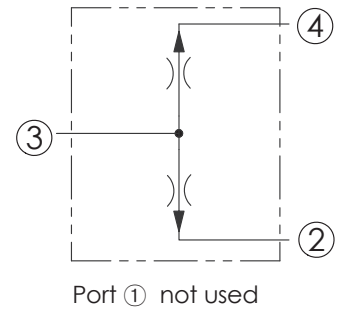

### TECHNICAL DATA

Pressure min-max:	10-350 bar
28 bar pressure drop at max.flow	
Rated Input Flow:	165 l/min
Cavity-Tooling:	16W-4
Installation torque:	60-70 Nm
Weight:	0.38 kg
Fluids-Temperatures:	-40~120 °C
Flow Accuracy:	10% from 40-100% of Max.Input flow
Filtration:	25 μm nominal or better
Mounting Position:	unrestricted

X	OPERATION
41	4 Ports;Flow Divider

Z	OPTION
N	Non-adjustable

## FLOW DIVIDER VALVES

Ordering Code: **FD-16W-X-Y-Z-6733**

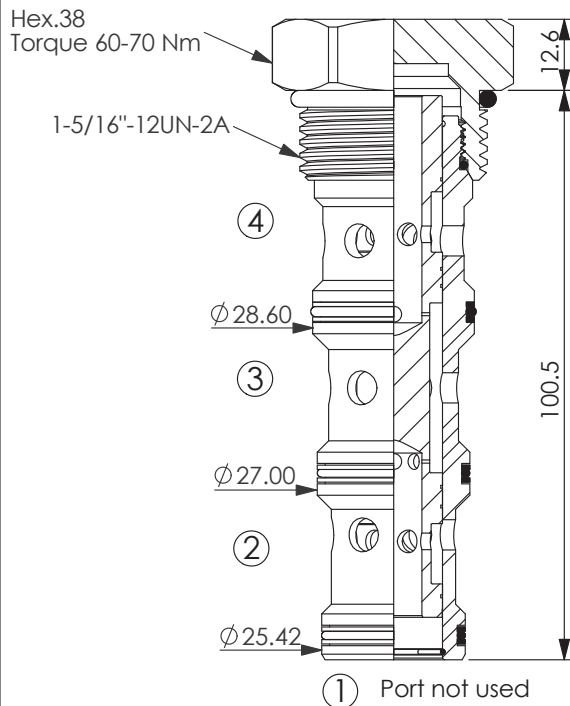

UNIT:mm

- (1)The FD16W-41 will divide input flow from ① to ② and ③, based on the ratio specified, regardless of operating pressure.  
 (2)Should either ② or ③ become blocked in flow division mode.  
 (3)NOTE:Flow combining is not permitted.

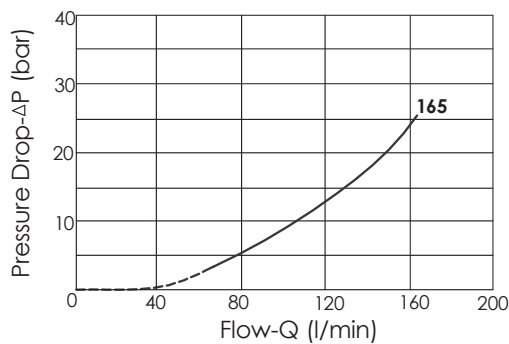

Y	NOMINAL CAPACITY
165	50-165 LPM Ratio 67:33 Port ②:Port ④ = 67:33 (Flow Ratio)
	Other ratio options available;consult factory

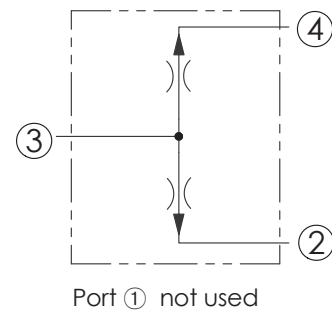

### TECHNICAL DATA

Pressure min-max:	10-350 bar
	28 bar pressure drop at max.flow
Rated Input Flow:	165 l/min
Cavity-Tooling:	16W-4
Installation torque:	60-70 Nm
Weight:	0.38 kg
Fluids-Temperatures:	-40~120 °C
Flow Accuracy:	10% from 40-100% of Max.Input flow
Filtration:	25 μm nominal or better
Mounting Position:	unrestricted

X	OPERATION
41	4 Ports;Flow Divider

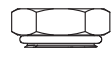
Z	OPTION
N	Non-adjustable 



Ordering Code: **FD-10W-X-Y-Z**

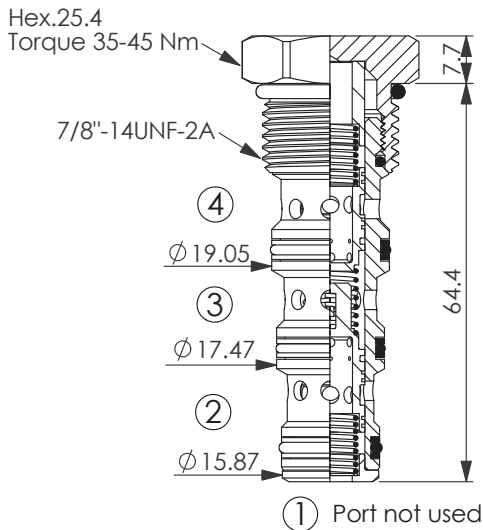

UNIT:mm

- (1)The FD10W-42 will divide input flow from ④ to ② and ③, based on the ratio specified, regardless of operating pressure.
- (2)The valve will combine input flow from both ② and ③ to ④.
- (3)The FD10W-42 will keep a flow to both combining ports ② and ③ when port ④ or ① is "free-wheeling." This function keeps parallel hydraulic-motor drive circuits from stalling in the combining mode.

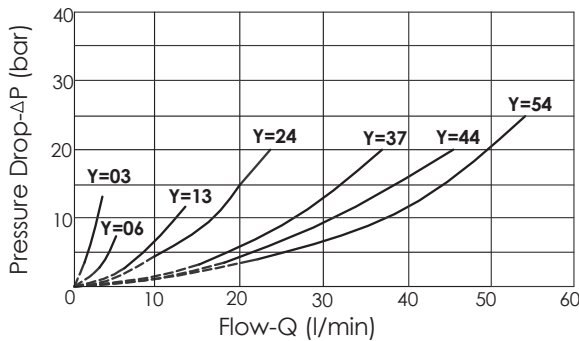

Y	NOMINAL CAPACITY
<b>03</b>	1.2- 3 LPM Ratio 50:50
<b>06</b>	3- 6 LPM Ratio 50:50
<b>13</b>	6-13 LPM Ratio 50:50
<b>24</b>	10-24 LPM Ratio 50:50
<b>37</b>	15-37 LPM Ratio 50:50
<b>44</b>	18-44 LPM Ratio 50:50
<b>54</b>	22-54 LPM Ratio 50:50
Other ratio options available;consult factory	

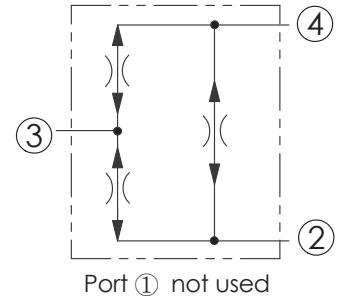

### TECHNICAL DATA

Pressure min-max:	10-350 bar
	28 bar pressure drop at max.flow
Rated Input Flow:	54 l/min
Cavity-Tooling:	10W-4
Installation torque:	35-45 Nm
Weight:	0.11 kg
Fluids-Temperatures:	-40~120 °C
Flow Accuracy:	10% from 40-100% of Max.Input flow
Filtration:	25 μm nominal or better
Mounting Position:	unrestricted

X	OPERATION
<b>42</b>	4 Ports; Flow Divider/Combiner (Anti-Stall Features)

Z	OPTION
<b>N</b>	Non-adjustable

Ordering Code: **FD-16W-X-Y-Z**

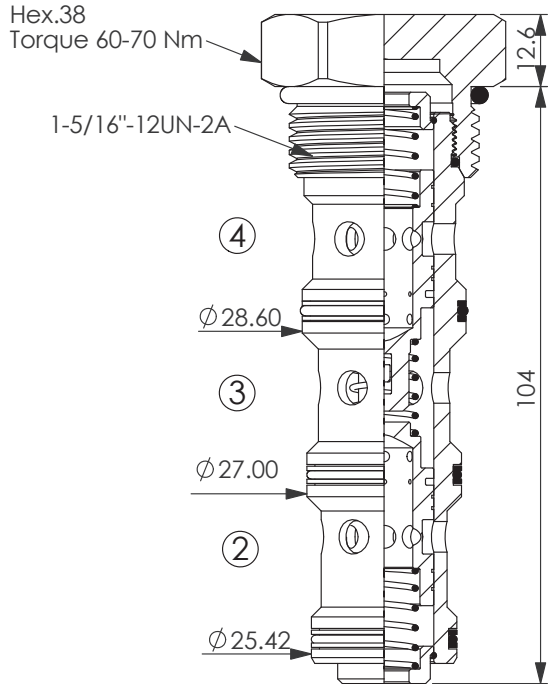

UNIT:mm

① Port not used

- (1)The FD16W-42 will divide input flow from ③ to ② and ④, based on the ratio specified, regardless of operating pressure.
- (2)The valve will combine input flow from both ② and ③ to ④.
- (3)The FD16W-42 will keep a flow to both combining ports ② and ③ when port ④ or ① is "free-wheeling." This function keeps parallel hydraulic-motor drive circuits from stalling in the combining mode.

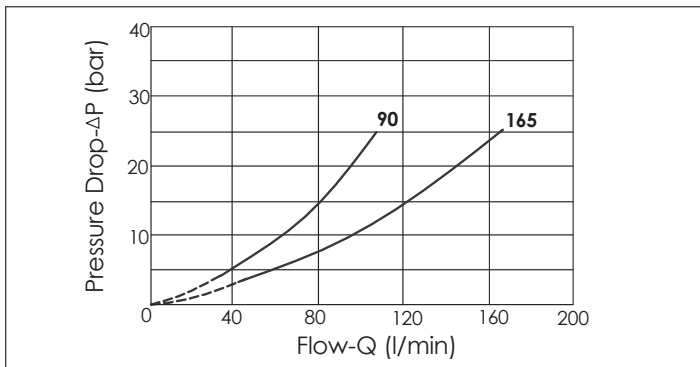

Y	NOMINAL CAPACITY	
90	30-90 LPM	Ratio 50:50
165	50-165 LPM	Ratio 50:50
Other ratio options available; consult factory		

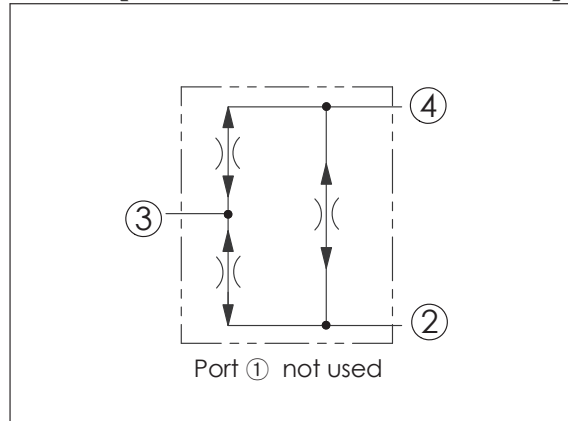

TECHNICAL DATA	
Pressure min-max:	10-350 bar 28 bar pressure drop at max.flow
Rated Input Flow:	165 l/min
Cavity-Tooling:	16W-4
Installation torque:	60-70 Nm
Weight:	0.38 kg
Fluids-Temperatures:	-40~120 °C
Flow Accuracy:	10% from 40-100% of Max.Input flow
Filtration:	25 μm nominal or better
Mounting Position:	unrestricted

X	OPERATION	
42	4 Ports; Flow Divider/Combiner (Anti-Stall Features)	

Z	OPTION	
N	Non-adjustable	

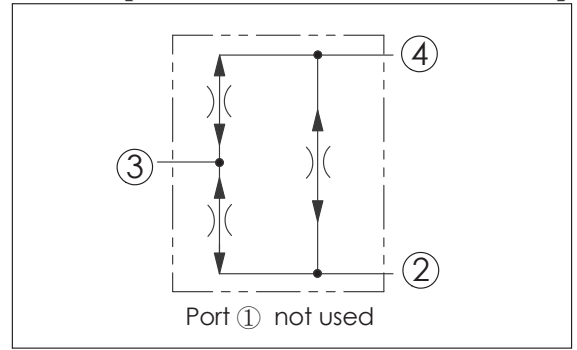
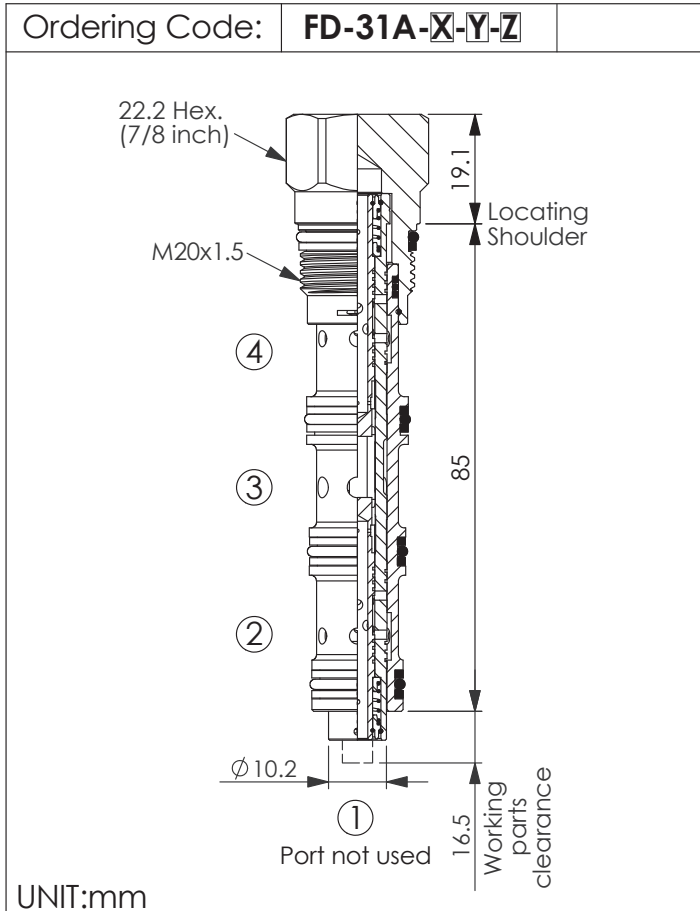

TECHNICAL DATA	
Max. pressure:	350 bar
Divisional accuracy at rated maximum input flow = 50% ± 2.0%	
Divisional accuracy at rated minimum input flow = 50% ± 3.5%	
Cavity-Tooling:	31A-4
Installation torque:	45-50 Nm
Weight:	0.16 kg

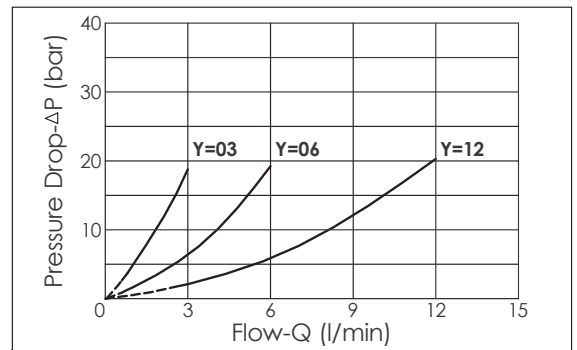

Capacity:1.2~3 LPM				
Split	Input Flow		Rated Accuracy	Maximum Possible Flow Variation
50:50	Max Rated	3 L/min	±2.0%	1.46~1.54 L/min
	Min Rated	0.8 L/min	±3.5%	0.37~0.43 L/min
Synchronizing Flow				0.6~1.0 L/min

Capacity:1.2~6 LPM				
Split	Input Flow		Rated Accuracy	Maximum Possible Flow Variation
50:50	Max Rated	6 L/min	±2.0%	2.9~3.1 L/min
	Min Rated	1 L/min	±3.5%	0.47~0.54 L/min
Synchronizing Flow				0.6~1.0 L/min

Capacity:2.5~12 LPM				
Split	Input Flow		Rated Accuracy	Maximum Possible Flow Variation
50:50	Max Rated	12 L/min	±2.0%	5.8~6.2 L/min
	Min Rated	2.5 L/min	±3.0%	1.2~1.3 L/min
Synchronizing Flow				0.6~1.2 L/min

The maximum possible variation is at 350 bar differential between legs with high pressure leg being the higher flow in dividing mode and the lower flow in combining mode

X	OPERATION	
42	4 Ports; Flow Divider/Combiner (Anti-Stall Features)	(This type will keep a flow to both combining ports ② and ④ when port ② or ④ is "free-wheeling." This function keeps parallel hydraulic-motor drive circuits from stalling in the combining mode.)

Y	NOMINAL CAPACITY	
03	0.8~3 LPM	
06	1.0~6 LPM	
12	2.5~12 LPM	

Z	OPTIONS	
A	Synchronizing High Accuracy	

Ordering Code: **FD-31A-X-Y-Z**

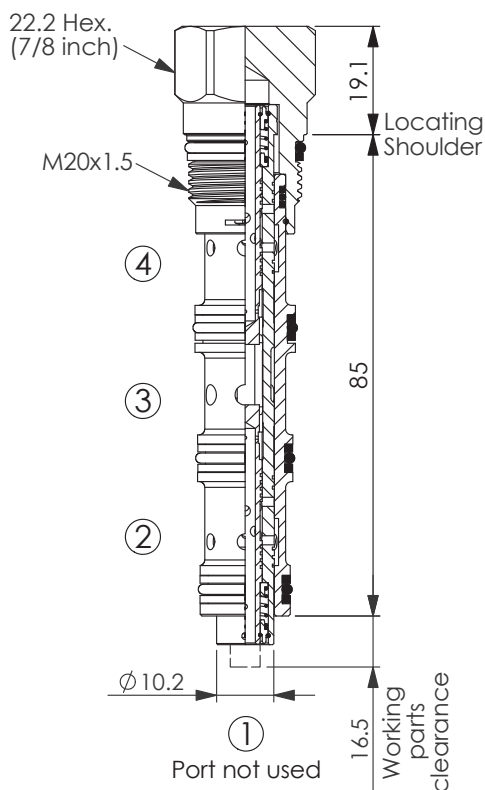

UNIT:mm

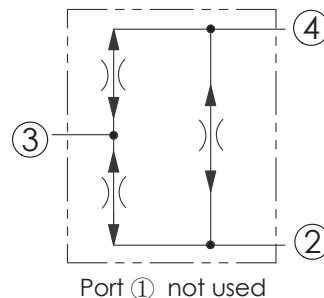

### TECHNICAL DATA

Max. pressure: 350 bar

Divisional accuracy at rated maximum input flow =  $50\% \pm 2.5\%$

Divisional accuracy at rated minimum input flow =  $50\% \pm 4.5\%$

Cavity-Tooling: 31A-4

Installation torque: 45-50 Nm

Weight: 0.16 kg

### Capacity:6~32 LPM

Split	Input Flow		Rated Accuracy	Maximum Possible Flow Variation
	Max Rated	32 L/min		
50:50	Max Rated	32 L/min	$\pm 2.5\%$	14.3~15.8 L/min
	Min Rated	6 L/min	$\pm 4.5\%$	2.73~3.27 L/min
Synchronizing Flow				0.94~2.46 L/min

The maximum possible variation is at 350 bar differential between legs with high pressure leg being the higher flow in dividing mode and the lower flow in combining mode

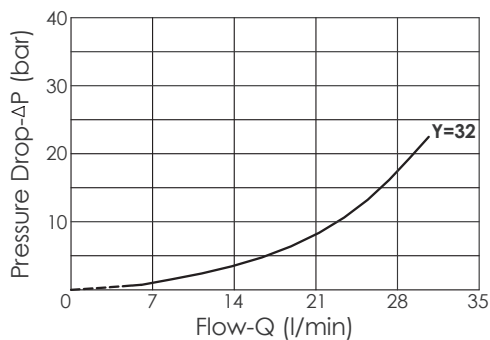

### X OPERATION

**42** 4 Ports;  
Flow Divider/Combiner  
(Anti-Stall Features)  
(This type will keep a flow to both combining ports ② and ④ when port ② or ④ is "free-wheeling." This function keeps parallel hydraulic-motor drive circuits from stalling in the combining mode.)

### Y NOMINAL CAPACITY

**32** 6~32 LPM

### Z OPTIONS

**N** Non-adjustable



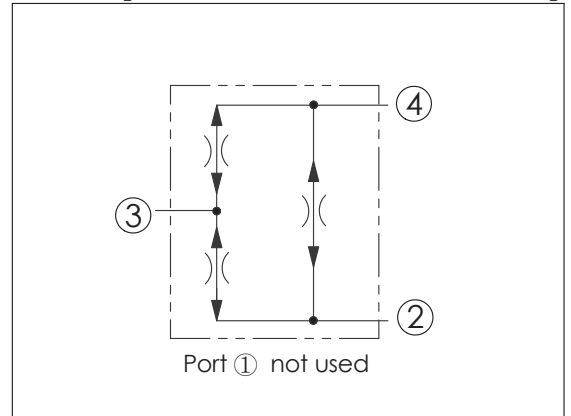
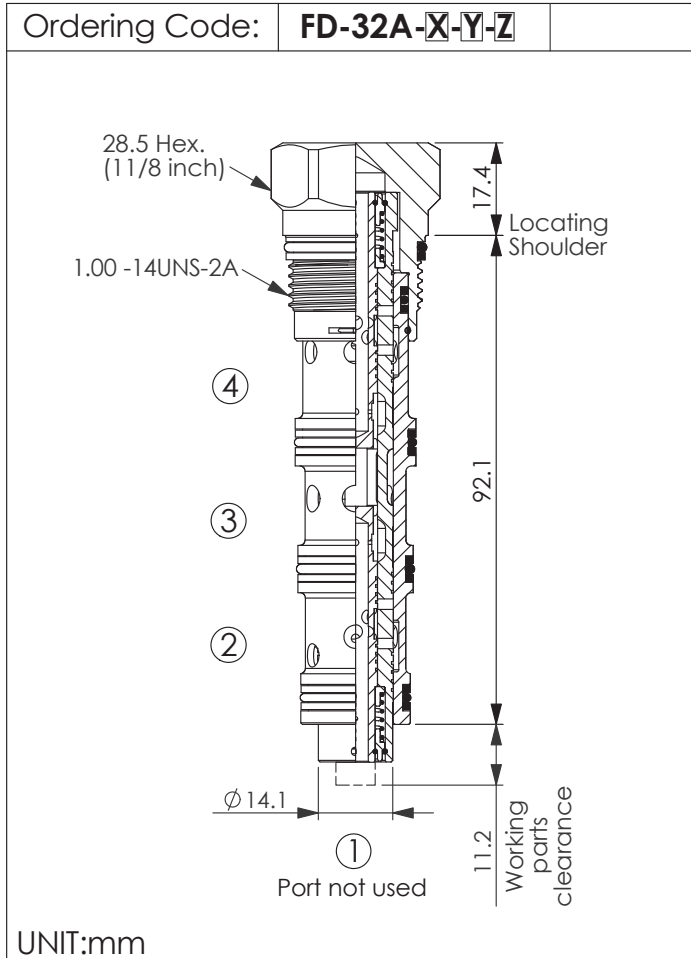

### TECHNICAL DATA

Max. pressure: 350 bar

Divisional accuracy at rated maximum input flow =  $50\% \pm 2.0\%$

Divisional accuracy at rated minimum input flow =  $50\% \pm 3.0\%$

Cavity-Tooling: 32A-4

Installation torque: 60-70 Nm

Weight: 0.27 kg

### Capacity:6~30 LPM

Split	Input Flow		Rated Accuracy	Maximum Possible Flow Variation
	Max Rated	30 L/min		
50:50	Min Rated	6 L/min	$\pm 3.0\%$	2.8~3.2 L/min
	Synchronizing Flow			1.1~2.8 L/min

The maximum possible variation is at 350 bar differential between legs with high pressure leg being the higher flow in dividing mode and the lower flow in combining mode

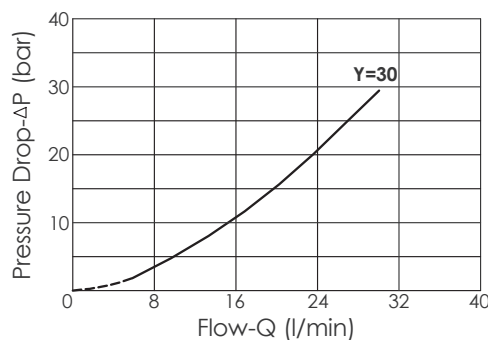

### X OPERATION

**42** 4 Ports;  
Flow Divider/Combiner  
(Anti-Stall Features)  
(This type will keep a flow to both combining ports ② and ④ when port ② or ④ is "free-wheeling." This function keeps parallel hydraulic-motor drive circuits from stalling in the combining mode.)

### Y NOMINAL CAPACITY

**30** 6~30 LPM

### Z OPTIONS

**A** Synchronizing  
High Accuracy

Ordering Code: **FD-32A-X-Y-Z**

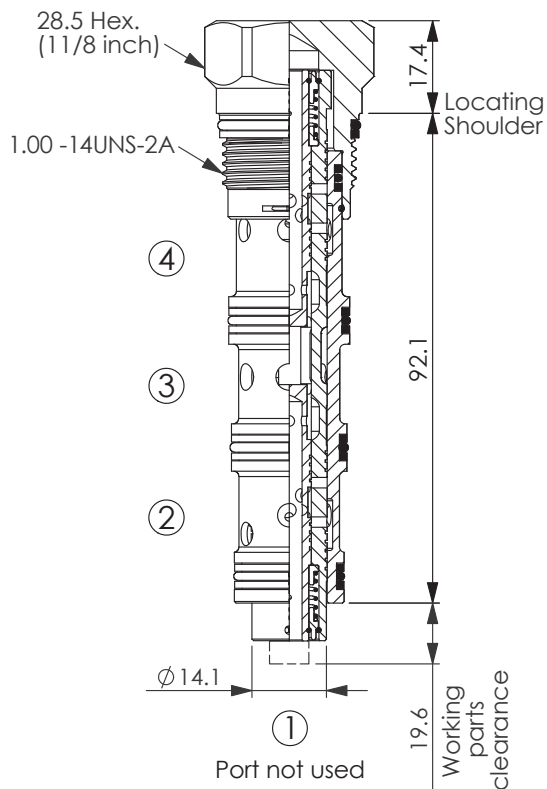

UNIT:mm

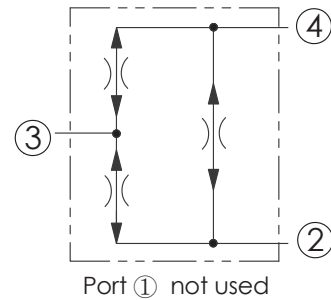

### TECHNICAL DATA

Max. pressure: 350 bar

Divisional accuracy at rated maximum input flow =  $50\% \pm 2.5\%$   
Divisional accuracy at rated minimum input flow =  $50\% \pm 4.5\%$

Cavity-Tooling: 32A-4

Installation torque: 60-70 Nm

Weight: 0.27 kg

### Capacity:12~60 LPM

Split	Input Flow		Rated Accuracy	Maximum Possible Flow Variation
	Max Rated	60 L/min		
50:50	Max Rated	60 L/min	$\pm 2.5\%$	28.5~31.5 L/min
	Min Rated	12 L/min	$\pm 4.5\%$	5.5~6.5 L/min
Synchronizing Flow				1.1~2.8 L/min

The maximum possible variation is at 350 bar differential between legs with high pressure leg being the higher flow in dividing mode and the lower flow in combining mode

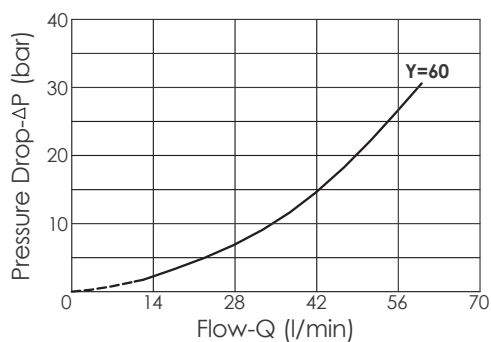

Rev.160726

### X OPERATION

**42** 4 Ports;  
Flow Divider/Combiner  
(Anti-Stall Features)  
(This type will keep a flow to both combining ports ② and ④ when port ② or ④ is "free-wheeling."  
This function keeps parallel hydraulic-motor drive circuits from stalling in the combining mode.)

### Y NOMINAL CAPACITY

**60** 12~60 LPM

### Z OPTIONS

**N** Non-adjustable

(FSDS)

B.603.212

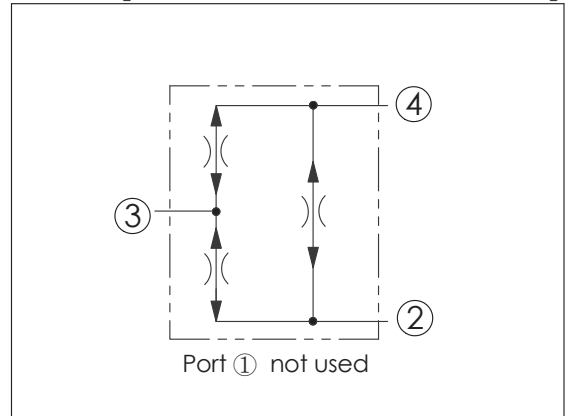
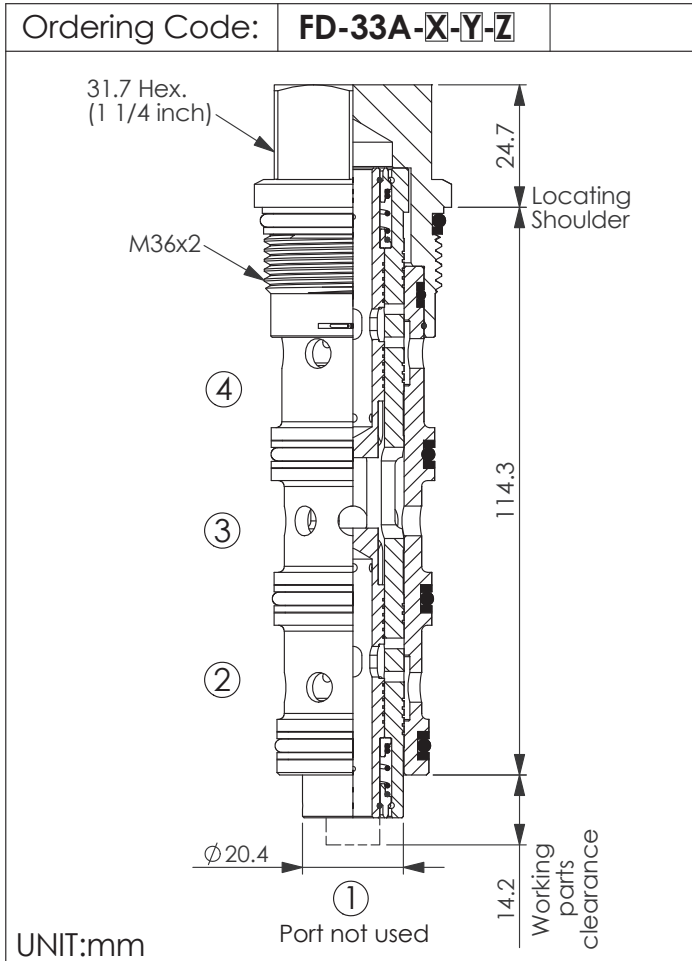

### TECHNICAL DATA

Max. pressure: 350 bar

Divisional accuracy at rated maximum input flow =  $50\% \pm 2.0\%$

Divisional accuracy at rated minimum input flow =  $50\% \pm 3.0\%$

Cavity-Tooling: 33A-4

Installation torque: 200-215 Nm

Weight: 0.65 kg

### Capacity:12~60 LPM

Split	Input Flow		Rated Accuracy	Maximum Possible Flow Variation
	Max Rated	60 L/min		
50:50	Max Rated	60 L/min	$\pm 2.0\%$	28.8~31.2 L/min
	Min Rated	12 L/min	$\pm 3.0\%$	5.6~6.4 L/min
Synchronizing Flow				3.4~6.6 L/min

The maximum possible variation is at 350 bar differential between legs with high pressure leg being the higher flow in dividing mode and the lower flow in combining mode

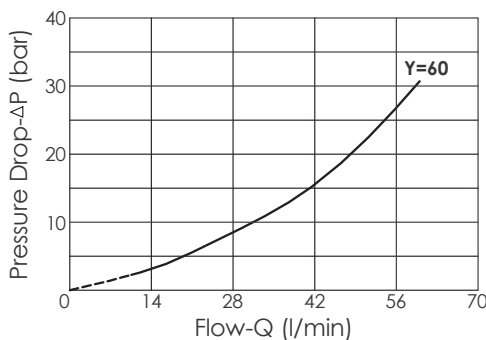

### X

### OPERATION

**42** 4 Ports;  
Flow Divider/Combiner  
(Anti-Stall Features)  
(This type will keep a flow to both combining ports ② and ④ when port ② or ④ is "free-wheeling."  
This function keeps parallel hydraulic-motor drive circuits from stalling in the combining mode.)

### Y

### NOMINAL CAPACITY

**60** 12~60 LPM

### Z

### OPTIONS

**A** Synchronizing  
High Accuracy

Ordering Code: **FD-33A-X-Y-Z**

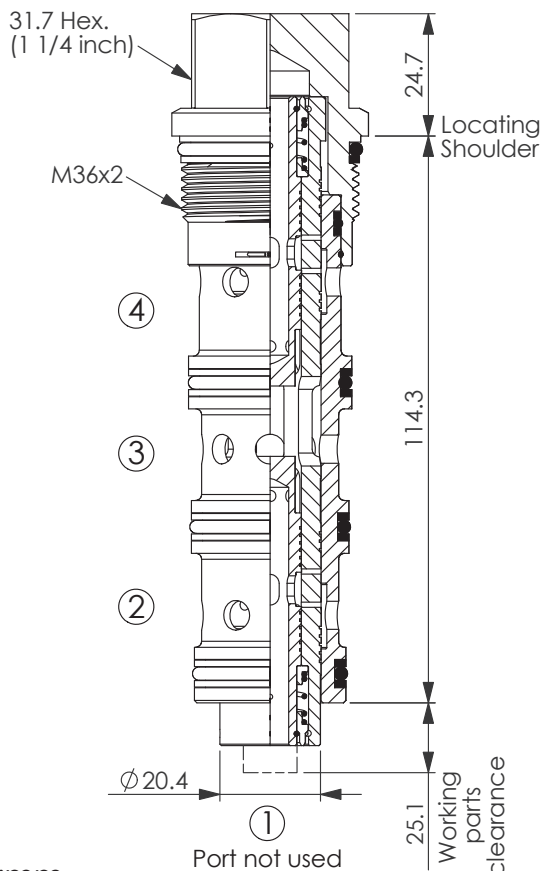

UNIT:mm

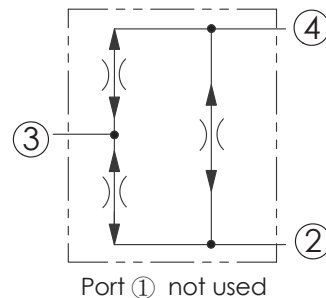

### TECHNICAL DATA

Max. pressure: 350 bar

Divisional accuracy at rated maximum input flow =  $50\% \pm 2.5\%$

Divisional accuracy at rated minimum input flow =  $50\% \pm 4.5\%$

Cavity-Tooling: 33A-4

Installation torque: 200-215 Nm

Weight: 0.65 kg

### Capacity:23~120 LPM

Split	Input Flow		Rated Accuracy	Maximum Possible Flow Variation
	Max Rated	Min Rated		
50:50	120 L/min	23 L/min	$\pm 2.5\%$	57~63 L/min
			$\pm 4.5\%$	10.5~12.5 L/min
Synchronizing Flow				3.4~6.6 L/min

The maximum possible variation is at 350 bar differential between legs with high pressure leg being the higher flow in dividing mode and the lower flow in combining mode

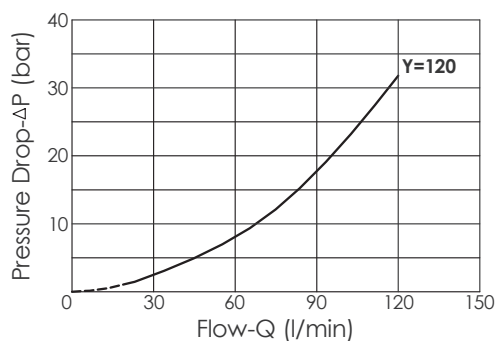

### X OPERATION

**42** 4 Ports;  
Flow Divider/Combiner  
(Anti-Stall Features)  
(This type will keep a flow to both combining ports ② and ④ when port ② or ④ is "free-wheeling."  
This function keeps parallel hydraulic-motor drive circuits from stalling in the combining mode.)

### Y NOMINAL CAPACITY

**120** 23~120 LPM

### Z OPTIONS

**N** Non-adjustable

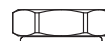



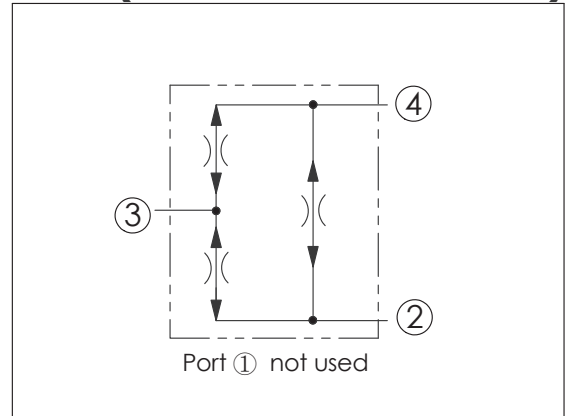
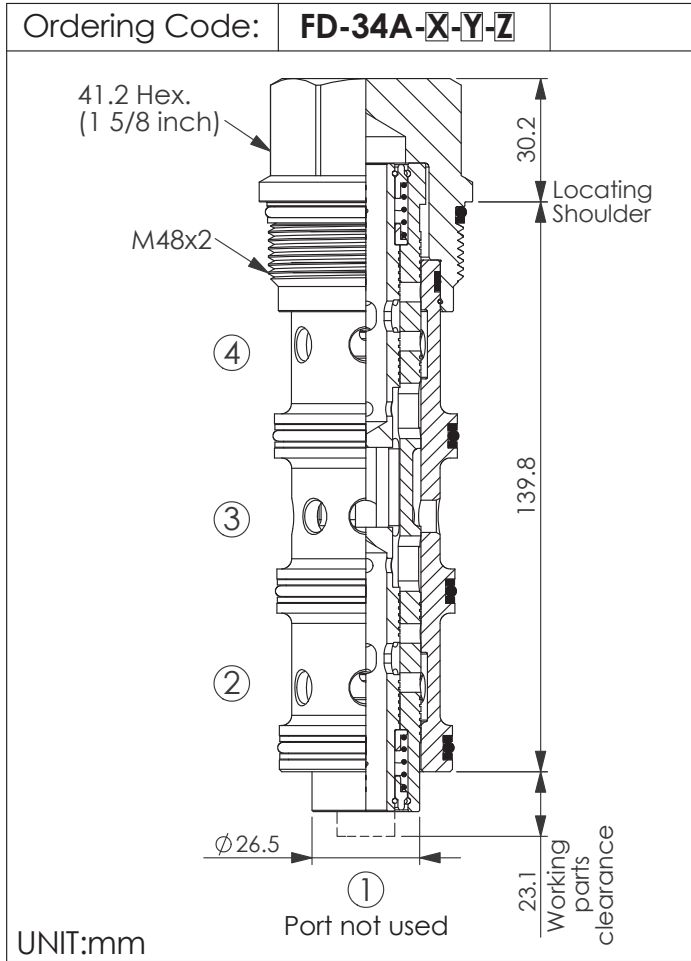

### TECHNICAL DATA

Max. pressure: 350 bar

Divisional accuracy at rated maximum input flow =  $50\% \pm 2.5\%$   
Divisional accuracy at rated minimum input flow =  $50\% \pm 4.5\%$

Cavity-Tooling: 34A-4

Installation torque: 475-510 Nm

Weight: 1.38 kg

### Capacity:45~240 LPM

Split	Input Flow		Rated Accuracy	Maximum Possible Flow Variation
	Max Rated	240 L/min		
50:50	Max Rated	240 L/min	$\pm 2.5\%$	108~119 L/min
	Min Rated	45 L/min	$\pm 4.5\%$	21~25 L/min
Synchronizing Flow				6.6~13.2 L/min

The maximum possible variation is at 350 bar differential between legs with high pressure leg being the higher flow in dividing mode and the lower flow in combining mode

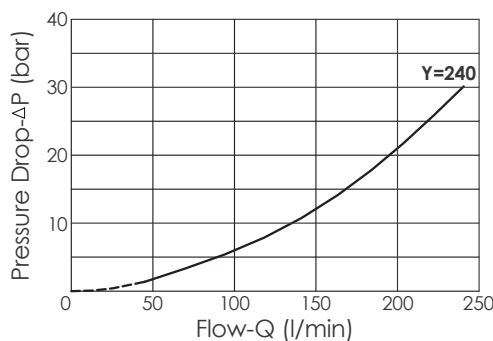

Rev.160726

### X

### OPERATION

**42** 4 Ports;  
Flow Divider/Combiner  
(Anti-Stall Features)  
(This type will keep a flow to both combining ports ② and ④ when port ② or ④ is "free-wheeling." This function keeps parallel hydraulic-motor drive circuits from stalling in the combining mode.)

### Y

### NOMINAL CAPACITY

**240**

45~240 LPM

### Z

### OPTIONS

**N**

Non-adjustable

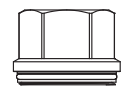

(FSFS)

B.603.231

## **CENTRALA ELBLĄG**

Ul. Rawska 19B  
82-300 Elbląg

tel. /+48/ 55 625 51 00

fax /+48/ 55 625 51 01

### **Dział Handlowy**

tel. /+48/ 55 625 51 51

[elblag@hydropress.pl](mailto:elblag@hydropress.pl)



[www.hydropress.pl](http://www.hydropress.pl)

### **ODDZIAŁ GDAŃSK**

tel. /+48/ 55 625 51 21

fax /+48/ 55 625 51 22

### **ODDZIAŁ RUMIA**

tel. /+48/ 58 679 34 15

fax /+48/ 55 625 51 25

### **ODDZIAŁ TYCHY**

tel. /+48/ 32 787 52 88

fax /+48/ 55 625 51 38

### **ODDZIAŁ OLSZTYN**

tel. /+48/ 89 532 01 05

fax /+48/ 89 715 21 42

### **ODDZIAŁ WARSZAWA**

tel. /+48/ 22 468 86 97

fax /+48/ 55 625 51 32

### **BIURO WE WROCŁAWIU**

tel. /+48/ 782 838 000

fax /+48/ 55 625 51 35

### **BIURO W KIELCACH**

tel. /+48/ 885 995 501

fax /+48/ 55 625 51 01

### **BIURO W KRAKOWIE**

tel. /+48/ 885 995 019

fax /+48/ 55 625 51 01

### **BIURO W OPOLU**

tel. /+48/ 885 995 011

fax /+48/ 55 625 51 01

### **BIURO W BYDGOSZCZY**

tel. /+48/ 790 222 771

fax /+48/ 55 625 51 01

### **BIURO W BIAŁYMSTOKU**

tel. /+48/ 89 532 01 05

fax /+48/ 89 715 21 42

### **BIURO W ŁODZI**

tel. /+48/ 609 221 421

fax /+48/ 89 715 21 42